



COPPER MOUNTAIN  
TECHNOLOGIES

# Planar 304/1, Planar 804/1 S5048 and S7530

Network Analyzer  
Operating Manual



Software Version 3.43  
Oct, 2014

# TABLE OF CONTENTS

<b>INTRODUCTION</b> .....	<b>8</b>
<b>SAFETY INSTRUCTIONS</b> .....	<b>9</b>
<b>1 GENERAL OVERVIEW</b> .....	<b>11</b>
1.1 Description .....	11
1.2 Specifications .....	11
1.3 Measurement Capabilities .....	11
1.4 Principle of Operation .....	19
<b>2 PREPARATION FOR USE</b> .....	<b>21</b>
2.1 General Information .....	21
2.2 Software Installation .....	21
2.3 Front Panel.....	23
2.3.1 Power Switch .....	24
2.3.2 Test Ports .....	24
2.4 Rear Panel .....	25
2.4.1 Power Cable Receptacle .....	26
2.4.2 External Trigger Signal Input Connector .....	26
2.4.3 External Reference Frequency Input Connector (Planar models) .....	26
2.4.4 Internal Reference Frequency Output Connector (Planar models).....	26
2.4.5 Reference Frequency Input/Output Connector (S models).....	26
2.4.6 USB 2.0 High Speed.....	27
2.4.7 Reserved Port (Planar 304/1) .....	27
<b>3 GETTING STARTED</b> .....	<b>28</b>
3.1 Analyzer Preparation for Reflection Measurement.....	29
3.2 Analyzer Presetting .....	29
3.3 Stimulus Setting.....	30
3.4 IF Bandwidth Setting.....	30
3.5 Number of Traces, Measured Parameter and Display Format Setting .....	31
3.6 Trace Scale Setting.....	32
3.7 Analyzer Calibration for Reflection Coefficient Measurement .....	32
3.8 .....	34
3.9 SWR and Reflection Coefficient Phase Analysis Using Markers.....	34
<b>4 SETTING MEASUREMENT CONDITIONS</b> .....	<b>36</b>
4.1 Screen Layout and Functions.....	36
4.1.1 Softkey Menu Bar .....	36

4.1.2	Menu Bar .....	38
4.1.3	Instrument Status Bar .....	39
4.2	Channel Window Layout and Functions .....	40
4.2.1	Channel Title Bar .....	41
4.2.2	Trace Status Field.....	42
4.2.3	Graph Area .....	44
4.2.4	Trace Layout in Channel Window.....	45
4.2.5	Markers.....	46
4.2.6	Channel Status Bar.....	47
4.3	Quick Channel Setting Using a Mouse .....	51
4.3.1	Active Channel Selection.....	51
4.3.2	Active Trace Selection .....	51
4.3.3	Measured Data Setting.....	51
4.3.4	Display Format Setting.....	51
4.3.5	Trace Scale Setting .....	52
4.3.6	Reference Level Setting.....	52
4.3.7	Reference Level Position .....	53
4.3.8	Sweep Start Setting.....	53
4.3.9	Sweep Stop Setting .....	53
4.3.10	Sweep Center Setting .....	53
4.3.11	Sweep Span Setting.....	54
4.3.12	Marker Stimulus Value Setting.....	54
4.3.13	Switching between Start/Center and Stop/Span Modes .....	54
4.3.14	Start/Center Value Setting .....	54
4.3.15	Stop/Span Value Setting.....	54
4.3.16	Sweep Points Number Setting.....	54
4.3.17	Sweep Type Setting.....	55
4.3.18	IF Bandwidth Setting.....	55
4.3.19	Power Level / CW Frequency Setting .....	55
4.4	Channel and Trace Display Setting .....	56
4.4.1	Channel Allocation.....	56
4.4.2	Number of Traces.....	57
4.4.3	Trace Allocation .....	58
4.4.4	Selection of Active Trace/Channel.....	61
4.4.5	Active Trace/Channel Window Maximizing.....	61
4.5	Stimulus Setting.....	63
4.5.1	Sweep Type Setting.....	63
4.5.2	Sweep Span Setting.....	63
4.5.3	Sweep Points Setting .....	64
4.5.4	Stimulus Power Setting.....	64
4.5.5	Setting Power Level for Each Port Individually .....	64
4.5.6	Power Slope Feature .....	65
4.5.7	CW Frequency Setting.....	65
4.5.8	RF Out Function .....	65
4.5.9	Segment Table Editing.....	66
4.5.10	Measurement Delay.....	68
4.6	Trigger Setting.....	69

4.6.1	Point Feature for the External Trigger (Planar 804/1 and S models)	71
4.6.2	External Trigger Polarity Setting (Planar 804/1 and S models)	71
4.7	Measurement Parameters Setting	72
4.7.1	S-Parameters	72
4.7.2	S-Parameter Setting	73
4.7.3	Absolute Measurements	73
4.7.4	Absolute Measurement Setting	74
4.8	Format Setting	75
4.8.1	Rectangular Formats	75
4.8.2	Polar Format	78
4.8.3	Smith Chart Format	79
4.8.4	Data Format Setting	81
4.9	Scale Setting	83
4.9.1	Rectangular Scale	83
4.9.2	Rectangular Scale Setting	83
4.9.3	Circular Scale	84
4.9.4	Circular Scale Setting	84
4.9.5	Automatic Scaling	85
4.9.6	Reference Level Automatic Selection	85
4.9.7	Electrical Delay Setting	85
4.9.8	Phase Offset Setting	86
4.10	Measurement Optimization	87
4.10.1	IF Bandwidth Setting	87
4.10.2	Averaging Setting	87
4.10.3	Smoothing Setting	88
4.11	Mixer Measurements	89
4.11.1	Mixer Measurement Methods	89
4.11.2	Frequency Offset Mode	90
4.11.3	Setting Start and Stop Values in Offset Frequency Mode	92
4.11.4	Source/Receivers Frequency Offset Feature	93
4.11.5	Automatic Adjustment of Offset Frequency	93
<b>5</b>	<b>CALIBRATION AND CALIBRATION KIT</b>	<b>96</b>
5.1	General Information	96
5.1.1	Measurement Errors	96
5.1.2	Systematic Errors	97
5.1.3	Error Modeling	98
5.1.4	Analyzer Test Port Definition	101
5.1.5	Calibration Steps	102
5.1.6	Calibration Methods	102
5.1.7	Calibration Standards and Calibration Kits	112
5.2	Calibration Procedures	118
5.2.1	Calibration Kit Selection	118
5.2.2	Reflection Normalization	119
5.2.3	Transmission Normalization	122
5.2.4	Full One-Port Calibration	123

5.2.5	One-Path Two-Port Calibration .....	126
5.2.6	Full Two-Port Calibration .....	128
5.2.7	TRL Calibration (Planar 804/1 and S models) .....	131
5.2.8	Calibration Using Subclasses .....	133
5.2.9	Calibration Using Sliding Load .....	136
5.2.10	Error Correction Disabling .....	136
5.2.11	Error Correction Status .....	137
5.2.12	System Impedance $Z_0$ .....	138
5.2.13	Port Extension .....	138
5.3	Calibration Kit Management .....	140
5.3.1	Table of Calibration Kits .....	140
5.3.2	Calibration Standard Definition .....	143
5.3.3	Table of Calibration Standard S-Parameters .....	147
5.3.4	Calibration Standard Class Assignment .....	149
5.4	Power Calibration .....	152
5.4.1	Loss Compensation Table .....	152
5.4.2	Power Calibration Procedure .....	153
5.4.3	Power Correction Setting .....	153
5.4.4	Loss Compensation Table Editing .....	153
5.5	Receiver Calibration .....	155
5.5.1	Receiver Calibration Procedure .....	155
5.5.2	Receiver Correction Setting .....	155
5.6	Scalar Mixer Calibration .....	156
5.7	Vector Mixer Calibration .....	160
5.7.1	Vector Mixer Calibration Procedure .....	161
5.8	Automatic Calibration Module .....	163
5.8.1	Automatic Calibration Module Features .....	164
5.8.2	Automatic Calibration Procedure .....	165
5.8.3	User Characterization Procedure .....	166
5.8.4	Confidence Check Procedure .....	168
<b>6</b>	<b>MEASUREMENT DATA ANALYSIS .....</b>	<b>169</b>
6.1	Markers .....	169
6.1.1	Marker Adding .....	171
6.1.2	Marker Deleting .....	171
6.1.3	Marker Stimulus Value Setting .....	171
6.1.4	Marker Activating .....	172
6.1.5	Reference Marker Feature .....	172
6.1.6	Marker Properties .....	173
6.1.7	Marker Position Search Functions .....	177
6.1.8	Marker Math Functions .....	183
6.1.9	Marker Functions .....	189
6.2	Memory Trace Function .....	190
6.2.1	Saving Trace into Memory .....	192
6.2.2	Trace Display Setting .....	193
6.2.3	Mathematical Operations .....	193

6.3	Fixture Simulation.....	194
6.3.1	Port Z Conversion.....	194
6.3.2	De-embedding.....	196
6.3.3	Embedding.....	197
6.4	Time Domain Transformation.....	199
6.4.1	Time Domain Transformation Activating.....	201
6.4.2	Time Domain Transformation Span.....	201
6.4.3	Time Domain Transformation Type.....	201
6.4.4	Time Domain Transformation Window Shape Setting.....	202
6.4.5	Frequency Harmonic Grid Setting.....	203
6.5	Time Domain Gating.....	204
6.5.1	Time Domain Gate Activating.....	205
6.5.2	Time Domain Gate Span.....	205
6.5.3	Time Domain Gate Type.....	206
6.5.4	Time Domain Gate Shape Setting.....	206
6.6	S-Parameter Conversion.....	207
6.7	General S-Parameter conversion.....	209
6.8	Limit Test.....	211
6.8.1	Limit Line Editing.....	212
6.8.2	Limit Test Enabling/Disabling.....	214
6.8.3	Limit Test Display Management.....	214
6.8.4	Limit Line Offset.....	214
6.9	Ripple Limit Test.....	215
6.9.1	Ripple Limit Editing.....	216
6.9.2	Ripple Limit Enabling/Disabling.....	218
6.9.3	Ripple Limit Test Display Management.....	218
<b>7</b>	<b>ANALYZER DATA OUTPUT.....</b>	<b>219</b>
7.1	Analyzer State.....	219
7.1.1	Analyzer State Saving.....	220
7.1.2	Analyzer State Recalling.....	221
7.1.3	Preserve Session.....	<b>Ошибка! Закладка не определена.</b>
7.2	Channel State.....	222
7.2.1	Channel State Saving.....	222
7.2.2	Channel State Recalling.....	222
7.3	Trace Data CSV File.....	223
7.3.1	CSV File Saving/Recalling.....	223
7.4	Trace Data Touchstone File.....	224
7.4.1	Touchstone File Saving/Recalling.....	226
<b>8</b>	<b>SYSTEM SETTINGS.....</b>	<b>227</b>
8.1	Analyzer Presetting.....	227
8.2	Graph Printing.....	227
8.3	Reference Frequency Oscillator Selection.....	228

8.4	System Correction Setting .....	229
8.5	Beeper Setting .....	230
8.6	User Interface Setting .....	231
8.7	Screen Update Setting .....	235
8.8	Power Meter Setting .....	236
8.9	Stimulus Frequency Adjustment (Planar 804/1 and S models) .....	238
8.10	Port Overload Indication (Planar 804/1 and S models) .....	239
8.11	Power Trip Function (Planar 804/1 and S models).....	239
<b>9</b>	<b>MAINTENANCE AND STORAGE .....</b>	<b>240</b>
9.1	Maintenance Procedures .....	240
9.1.1	Instrument Cleaning.....	240
9.1.2	Factory Calibration.....	241
9.1.3	Performance Test .....	241
9.2	Storage Instructions.....	241
<b>10</b>	<b>WARRANTY INFORMATION .....</b>	<b>242</b>
	<b>Appendix 1 – Default Settings Table .....</b>	<b>243</b>

## INTRODUCTION

This Operating Manual contains design, specifications, functional overview, and detailed operation procedures for the Network Analyzer, to ensure effective and safe use of its technical capabilities by the user.

Maintenance and operation of the Analyzer should be performed by qualified engineers with basic experience in operating of microwave circuits and PC.

The following abbreviations are used in this Manual:

- PC – Personal Computer
- DUT – Device Under Test
- IF – Intermediate Frequency
- CW – Continuous Wave
- SWR – Standing Wave Ratio
- CMT – Copper Mountain Technologies



## SAFETY INSTRUCTIONS

Carefully read the following safety instructions before putting the Analyzer into operation. Observe all the precautions and warnings provided in this Manual for all the phases of operation, service, and repair of the Analyzer.

The Analyzer should be used only by skilled and thoroughly trained personnel with the required skills and knowledge of safety precautions.

The Analyzer complies with INSTALLATION CATEGORY II as well as POLLUTION DEGREE 2 as defined in IEC61010–1. The Analyzer is a MEASUREMENT CATEGORY I (CAT I) device. Do not use the Analyzer as a CAT II, III, or IV device.

The Analyzer is for INDOOR USE only.

The Analyzer has been tested as a stand-alone device and in combination with the accessories supplied by Copper Mountain Technologies, in accordance with the requirements of the standards described in the Declaration of Conformity. If the Analyzer is integrated with another system, compliance with related regulations and safety requirements are to be confirmed by the builder of the system.

Never operate the Analyzer in an environment containing flammable gasses or fumes.

Operators must not remove the cover or any other part of the housing. The Analyzer must not be repaired by the operator. Component replacement or internal adjustment must be performed by qualified maintenance personnel only.

Never operate the Analyzer if the power cable is damaged. Never connect the test ports to A/C power mains.

Electrostatic discharge can damage the Analyzer whether connected to or disconnected from the DUT. Static charge can build up on your body and damage sensitive internal components of both the Analyzer and the DUT. To avoid damage from electric discharge, observe the following:

- Always use a desktop anti-static mat under the DUT.
- Always wear a grounding wrist strap connected to the desktop anti-static mat via daisy-chained 1 M $\Omega$  resistor.
- Connect the post marked  on the body of the Analyzer to the body of the DUT before you start operation.

Observe all general safety precautions related to operation of electrically energized equipment.

The definitions of safety symbols used on the instrument and in the Manual are listed below.



Refers to the Manual if the instrument is marked with this symbol.



Alternating current.



Direct current.



On (Supply).



Off (Supply).



A chassis terminal; a connection to the instrument's chassis, which includes all exposed metal surfaces.

<b>WARNING</b>	<b>This sign denotes a hazard. It calls attention to a procedure, practice, or condition that, if not correctly performed or adhered to, could result in injury or death to personnel.</b>
CAUTION	This sign denotes a hazard. It calls attention to a procedure, practice, or condition that, if not correctly performed or adhered to, could result in damage to or destruction of part or all of the instrument.
Note	This sign denotes important information. It calls attention to a procedure, practice, or condition that is essential for the user to understand.

# 1 GENERAL OVERVIEW

## 1.1 Description

The Analyzer is designed for use in the process of development, adjustment and testing of various electronic devices in industrial and laboratory facilities, including operation as a component of an automated measurement system. The Analyzer is designed for operation with an external PC, which is not supplied with the Analyzer.

## 1.2 Specifications

The specifications of each Analyzer model can be found in its corresponding datasheet.

## 1.3 Measurement Capabilities

Measured parameters	$S_{11}, S_{21}, S_{12}, S_{22}$  Absolute power of the reference and received signals at the port.
Number of measurement channels	Up to 16 logical channels. Each logical channel is represented on the screen as an individual channel window. A logical channel is defined by such stimulus signal settings as frequency range, number of test points, power level, etc.
Data traces	Up to 16 data traces can be displayed in each channel window. A data trace represents one of the following parameters of the DUT: S-parameters, response in the time domain, or input power response.
Memory traces	Each of the 16 data traces can be saved into memory for further comparison with the current values.
Data display formats	Logarithmic magnitude, linear magnitude, phase, expanded phase, group delay, SWR, real part, imaginary part, Smith chart format and polar format.

**Sweep setup features**

Sweep type	Linear frequency sweep, logarithmic frequency sweep, and segment frequency sweep, when the stimulus power is a fixed value; and linear power sweep when frequency is a fixed value.
Measured points per sweep	From 2 to the instrument maximum.
Segment sweep	A frequency sweep within several user-defined segments. Frequency range, number of sweep points, source power, and IF bandwidth can be set for each segment.
Power settings	Source power from instrument minimum to instrument maximum with resolution of 0.05 dB. In frequency sweep mode the power slope can be set to up to 2 dB/GHz to compensate high frequency attenuation in cables.
Sweep trigger	Trigger modes: continuous, single, hold. Trigger sources: internal, manual, external, bus.

**Trace display functions**

Trace display	Data trace, memory trace, or simultaneous data and memory traces.
Trace math	Data trace modification by math operations: addition, subtraction, multiplication or division of measured complex values and memory data.
Autoscaling	Automatic selection of scale division and reference level value to have the trace most effectively displayed.
Electrical delay	Calibration plane compensation for delay in the test setup, or for electrical delay in a DUT during measurements of deviation from linear phase.
Phase offset	Phase offset in degrees.

## Accuracy enhancement

Calibration	Calibration of a test setup (which includes the Analyzer, cables, and adapters) significantly increases the accuracy of measurements. Calibration allows for correction of errors caused by imperfections in the measurement system: system directivity, source and load match, tracking, and isolation.
Calibration methods	<p>The following calibration methods of various sophistication and accuracy enhancement are available:</p> <ul style="list-style-type: none"> <li>▪ reflection and transmission normalization;</li> <li>▪ full one-port calibration;</li> <li>▪ one-path two-port calibration</li> <li>▪ full two-port calibration;</li> <li>▪ TRL calibration (Planar 804/1 and S models).</li> </ul>
Reflection and transmission normalization	The simplest calibration method. It provides limited accuracy.
Full one-port calibration	Method of calibration performed for one-port reflection measurements. It ensures high accuracy.
One-path two-port calibration	Method of calibration performed for reflection and one-way transmission measurements, for example for measuring $S_{11}$ and $S_{21}$ only. It ensures high accuracy for reflection measurements, and reasonable accuracy for transmission measurements.
Full two-port calibration	Method of calibration performed for full S-parameter matrix measurement of a two-port DUT. It ensures high accuracy.
TRL calibration (Planar 804/1 and S models)	Method of calibration performed for full S-parameter matrix measurement of a two-port DUT. LRL and LRM types of this calibration are also supported. In ensures higher accuracy than a two-port calibration.

Mechanical calibration kits	The user can select one of the predefined calibration kits of various manufacturers or define additional calibration kits.
Electronic calibration modules	Copper Mountain Technologies' automatic calibration modules make the Analyzer calibration faster and easier than traditional mechanical calibration.
Sliding load calibration standard	The use of sliding load calibration standard allows significant increase in calibration accuracy at high frequencies compared to a fixed load calibration standard.
Unknown thru calibration standard (Planar 804/1 and S models)	The use of an arbitrary reciprocal two-port device instead of a zero-length thru during a full two-port calibration allows for calibration of the test setup for measurements of non-insertable devices.
Defining of calibration standards	Different methods of calibration standard definition are available: <ul style="list-style-type: none"> <li>▪ standard definition by polynomial model</li> <li>▪ standard definition by data (S-parameters).</li> </ul>
Error correction interpolation	When the user changes such settings as start/stop frequencies and number of sweep points, compared to the settings of calibration, interpolation or extrapolation of the calibration coefficients will be applied.
<b>Supplemental calibration methods</b>	
Power calibration	Method of calibration which allows for maintaining more stable power levels at the DUT input. An external power meter should be connected to the USB port directly or via USB/GPIB adapter.
Receiver calibration	Method of calibration which calibrates the receiver gain at absolute signal power measurement.

**Marker functions**

Data markers	Up to 16 markers for each trace. A marker indicates the stimulus value and measurement result at a given point of the trace.
Reference marker	Enables indication of any marker value as relative to the reference marker.
Marker search	Search for max, min, peak, or target values on a trace.
Marker search additional features	User-definable search range. Available as either a tracking marker, or as a one-time search.
Setting parameters by markers	Setting of start, stop and center frequencies from the marker frequency, and setting of reference level by the measurement result of the marker.
Marker math functions	Statistics, bandwidth, flatness, RF filter.
Statistics	Calculation and display of mean, standard deviation and peak-to-peak in a frequency range limited by two markers on a trace.
Bandwidth	Determines bandwidth between cutoff frequency points for an active marker or absolute maximum. The bandwidth value, center frequency, lower frequency, higher frequency, Q value, and insertion loss are displayed.
Flatness	Displays gain, slope, and flatness between two markers on a trace.
RF filter	Displays insertion loss and peak-to-peak ripple of the passband, and the maximum signal magnitude in the stopband. The passband and stopband are defined by two pairs of markers.

## Data analysis

Port impedance conversion	The function converts S-parameters measured at the analyzer's nominal port impedance into values which would be found if measured at a test port with arbitrary impedance.
De-embedding	The function allows mathematical exclusion of the effects of the fixture circuit connected between the calibration plane and the DUT. This circuit should be described by an S-parameter matrix in a Touchstone file.
Embedding	The function allows mathematical simulation of the DUT parameters after virtual integration of a fixture circuit between the calibration plane and the DUT. This circuit should be described by an S-parameter matrix in a Touchstone file.
S-parameter conversion	The function allows conversion of the measured S-parameters to the following parameters: reflection impedance and admittance, transmission impedance and admittance, and inverse S-parameters.
Time domain transformation	The function performs data transformation from frequency domain into response of the DUT to various stimulus types in time domain. Modeled stimulus types: bandpass, lowpass impulse, and lowpass step. Time domain span is set by the user arbitrarily from zero to maximum, which is determined by the frequency step. Various window shapes allow optimizing the tradeoff between resolution and level of spurious sidelobes.
Time domain gating	The function mathematically removes unwanted responses in time domain, allowing for obtaining frequency response without the influence of the fixture elements. The function applies a reverse transformation back to the frequency domain from the user-defined span in the time domain. Gating filter types: bandpass or notch. For better tradeoff between gate resolution and level of spurious sidelobes the following filter shapes are available: maximum, wide, normal and minimum.



---

**Mixer / converter measurements**

Scalar mixer / converter measurements	The scalar method allows measurement of scalar transmission S-parameters of mixers and other devices having different input and output frequencies. No external mixers or other devices are required. The scalar method employs port frequency offset when there is a difference between receiver frequency and source frequency.
---	---

Vector mixer / converter measurements	The vector method allows measuring of the mixer transmission S-parameter magnitude and phase. The method requires an external mixer and an LO common to both the external mixer and the mixer under test.
---	---

Scalar mixer / converter calibration	The most accurate method of calibration applied for measurements of mixers in frequency offset mode. The OPEN, SHORT, and LOAD calibration standards are used. An external power meter should be connected to the USB port directly or via USB/GPIB adapter.
---	--

Vector mixer /converter calibration	Method of calibration applied for vector mixer measurements. The OPEN, SHORT and LOAD calibration standards are used.
--	---

Automatic adjustment of frequency offset	The function performs automatic frequency offset adjustment when scalar mixer / converter measurements are performed to compensate for LO frequency inaccuracies internal to the DUT.
---	---

---

**Other features**

Familiar graphical user interface	Graphical user interface based on the Windows operating system ensures fast and easy Analyzer operation by the user.
--------------------------------------	--

Analyzer control	Using a personal computer.
------------------	----------------------------

Printout/saving of traces	The traces and data printout function has a preview feature. Previewing, saving and printing can be performed using MS Word, Image Viewer for Windows, or the Analyzer Print Wizard.
------------------------------	--

---

**Remote control**

---

**COM/DCOM**

Remote control over COM/DCOM. COM automation runs the user program on an Analyzer PC. DCOM automation runs the user program on a LAN-networked PC.

---

## 1.4 Principle of Operation

The block diagram of the Analyzer is represented in Figure 1.

The Analyzer Unit consists of a source oscillator, local oscillator, source power attenuator, and a switch connecting the source signal to two directional couplers, which are connected to the Port 1 and Port 2 connectors. The incident and reflected waves from the directional couplers are passed into the mixers, where they are converted to first IF (10.7 MHz for Planar models; 0.4 MHz for S models) and are passed further to the 4-Channel receiver. The 4-Channel receiver, after filtering, digitally encodes the signal and supplies it for further processing (filtration, phase difference estimation, magnitude measurement) by the signal processor. The IF measurement filters are digital and have bandwidths of between the instrument minimum (1 Hz for Planar models; 10 Hz for S models) to 30 kHz. Either port of the Analyzer can be a source of the tested signal as well as a receiver of the signal transferred through the DUT. If Port 1 is a source, Port 2 will be a receiver. The definition “incident and reflected” wave is correct for the port when it is a source of the test signal. The combination of the assemblies of directional couplers, mixers and 4-Channel receiver forms four similar signal receivers.

An external PC controls the operation of the components of the Analyzer. To perform S-parameter measurements, the Analyzer supplies the source signal of the assigned frequency from one of the ports to the DUT, then measures magnitude and phase of the signals transmitted through and reflected by the DUT, and finally compares these results to the magnitude and phase of the source signal.

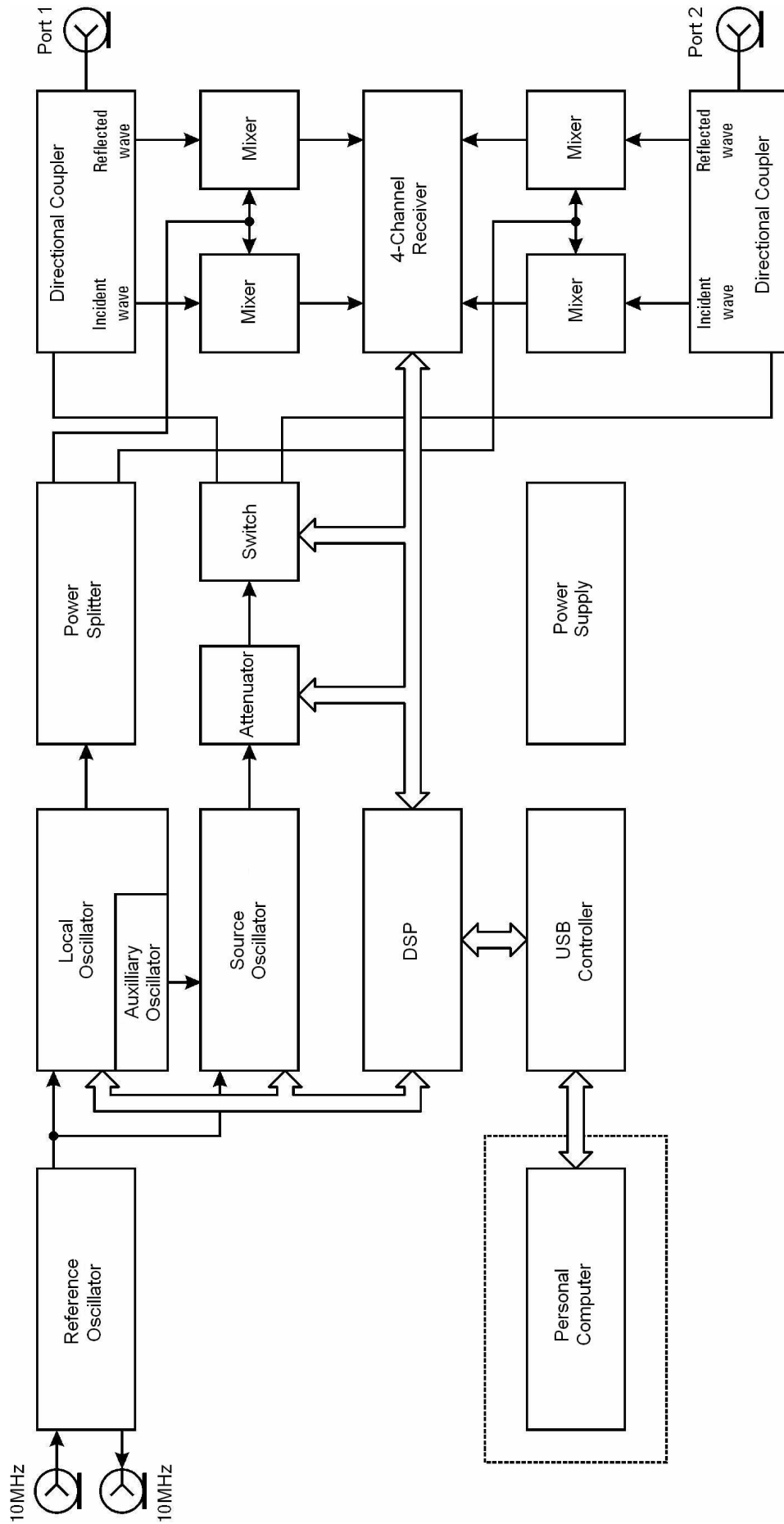

Figure 1 Analyzer Block Diagram. In S models, the 10 MHz reference input and output are connected internally to a single physical connector.

## 2 PREPARATION FOR USE

### 2.1 General Information

Unpack the Analyzer and other accessories. Connect the Analyzer to a 100 VAC to 240 VAC 50/60 Hz power source by means of the external Power Supply (S models models) or Power Cable (Planar models) supplied with the instrument. Connect the USB-port of your Analyzer to the PC using the USB Cable supplied in the package. Install the software from [www.coppermountaintech.com](http://www.coppermountaintech.com) onto your PC. The software installation procedure is described in section 2.2.

Warm up the Analyzer for the time stated in its specifications.

Assemble the test setup using cables, connectors, fixtures, etc., which allow DUT connection to the Analyzer.

Perform calibration of the Analyzer. Calibration procedures are described in section 5.

### 2.2 Software Installation

Connect the Analyzer to your PC via USB interface and install the Analyzer software from [www.coppermountaintech.com](http://www.coppermountaintech.com).

---

Minimal system requirements for the PC	WINDOWS 2000/XP/VISTA/7
	1.5 GHz Processor
	1 GB RAM
	USB 2.0 High Speed

---

---

Program and other files installation	Run the <b>Setup_Analyzer_vX.X.exe</b> installer file. Follow the instructions of the installation wizard.
Driver installation	<p>Connect the Analyzer to your PC via the supplied USB cable. It is allowed to connect the USB cable to the running PC.</p> <p>Turn on and boot the PC, if it is off.</p> <p>Turn the Analyzer on by the Power key on the front panel.</p> <p>When you connect the Analyzer to the PC for the first time, Windows will automatically detect the new USB device and install the drivers automatically.</p> <p>Should automatic driver installation fail, open the USB driver installation dialog as follows: <b>Start &gt; Control Panel &gt; Device Manager</b>. Make the right mouse click on the <i>Unknown Device</i> line and select <b>Update Drivers</b>.</p> <p>In the USB driver installation dialog, click on <b>Browse</b> and specify the path to the driver files, which are contained in the \DRIVER folder in the Analyzer's software folder.</p> <p>When the driver is installed, a new USB device (Network Analyzer) will appear in the system.</p>

---

## 2.3 Front Panel

The front view of the Analyzers are represented in the figures below. The front panel is equipped with the following parts:

- Power switch;
- Test ports.



Figure 2 Planar 804/1 front panel

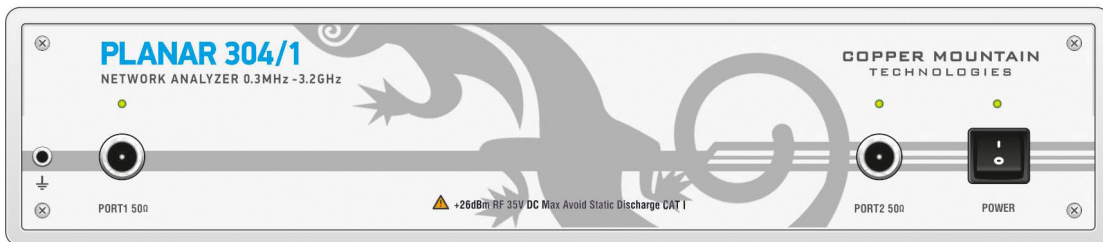

Figure 3 Planar 304/1 front panel

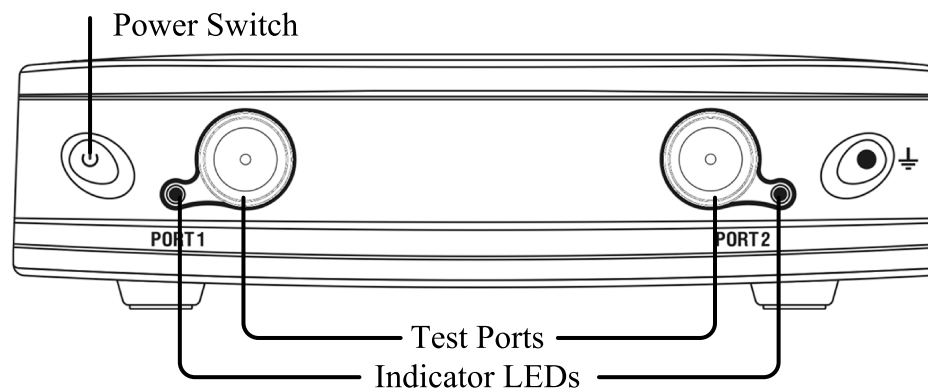

Figure 4 S models' front panel

### 2.3.1 Power Switch

---

Switches the power supply of the Analyzer on and off.

You can turn your Analyzer on/off at any time. After power-on of the Analyzer connected to PC, the program will begin downloading embedded firmware into the Analyzer. The process will take approximately 10 seconds, after which the Analyzer will be ready for operation.

---

Note

When you turn on your Analyzer for the first time, the USB driver will be installed onto the PC. The driver installation procedure is described in section 2.2. Some computers may require re-installation of the driver in case of change of the USB port.

---

### 2.3.2 Test Ports

---

The type-N test Port 1 and test Port 2 are intended for DUT connection. Each test port has a LED indicator. A test port can be used either as a source of the stimulus signal or as a receiver of the response signal of the DUT. Only one of the ports can be the source of the signal at a particular moment of time.

If you connect the DUT to only one test port of the Analyzer, you will be able to measure the reflection parameters (e.g.  $S_{11}$  or  $S_{22}$ ) of the DUT.

If you connect the DUT to all test ports of the Analyzer, you will be able to measure the full S-parameter matrix of the DUT.

---

Note

LED indicator identifies the test port which is operating as a signal source.

---

CAUTION

Do not exceed the maximum allowed power of the input RF signal (or maximum DC voltage) indicated on the front panel. This may damage your Analyzer.

---



## 2.4 Rear Panel

The rear view of Planar 304/1 is represented in Figure 5; the rear panel of the Planar 804/1 is similar. The rear view of the S models is represented in Figure 6. The rear panel is equipped with the following parts:

- Power cable or power supply receptacle;
- External trigger input connector;
- External Reference Frequency input/output connector(s);
- USB 2.0 High Speed receptacle;
- Reserved port (Planar 304/1 only).

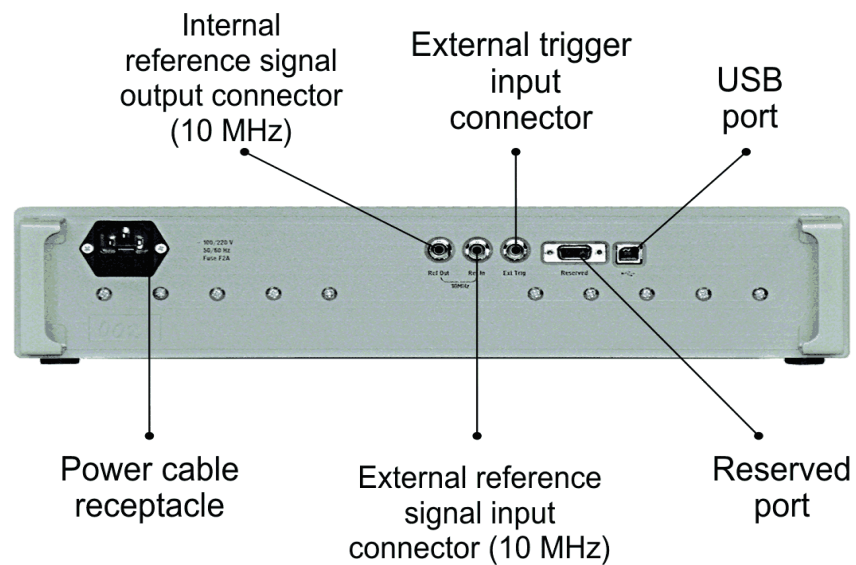

Figure 5 Planar 304/1 rear panel

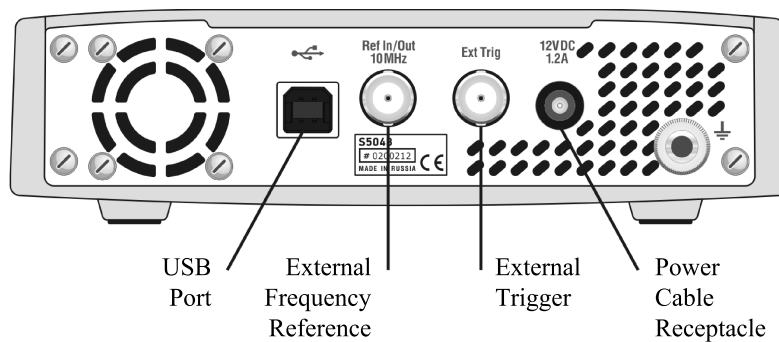

Figure 6 S models' rear panel

### 2.4.1 Power Cable Receptacle

---

The power cable receptacle (Planar models) is intended for 100 VAC to 240 VAC 50/60 Hz power cable connection. The power supply receptacle (S models) is intended for an external DC power supply voltage from 9 to 15 V; alternatively the power supply can be powered by a battery, including a vehicle battery, through an appropriate vehicle power cable.

### 2.4.2 External Trigger Signal Input Connector

---

This connector allows the user to connect an external trigger source. Connector type is BNC female. TTL compatible inputs of 3 V to 5 V magnitude have up to 1  $\mu$ s pulse width. Input impedance at least 10 k $\Omega$ .

---

### 2.4.3 External Reference Frequency Input Connector (Planar models)

---

External reference frequency is 10 MHz, input level is 2 dBm  $\pm$  2 dB, input impedance at «Ref In» is 50  $\Omega$ . Connector type is BNC female.

---

### 2.4.4 Internal Reference Frequency Output Connector (Planar models)

---

Output reference signal level is 3 dBm  $\pm$  2 dB at 50  $\Omega$  impedance. «Ref Out» connector type is BNC female.

---

### 2.4.5 Reference Frequency Input/Output Connector (S models)

---

External reference frequency is 10 MHz, input level is 2 dBm  $\pm$  3 dB, input impedance 50  $\Omega$ . Output reference signal level is 3 dBm  $\pm$  2 dB into 50  $\Omega$  impedance. Connector type is BNC female.

---

## 2.4.6 USB 2.0 High Speed

---

The USB port is intended for connection to a computer.

---

## 2.4.7 Reserved Port (Planar 304/1)

---

Note	Do not use this port.
------	-----------------------

---

### 3 GETTING STARTED

This section is organized as a sample session of the Analyzer. It describes the main techniques of measurement of reflection coefficient parameters of the DUT. SWR and reflection coefficient phase of the DUT will be analyzed.

For reflection coefficient measurement only one test port of the Analyzer is used. The instrument sends the stimulus to the input of the DUT and then receives the reflected wave. Generally in the process of this measurement the output of the DUT should be terminated with a LOAD standard. The results of these measurements can be represented in various formats.

Typical circuit of reflection coefficient measurement is shown in Figure 7.

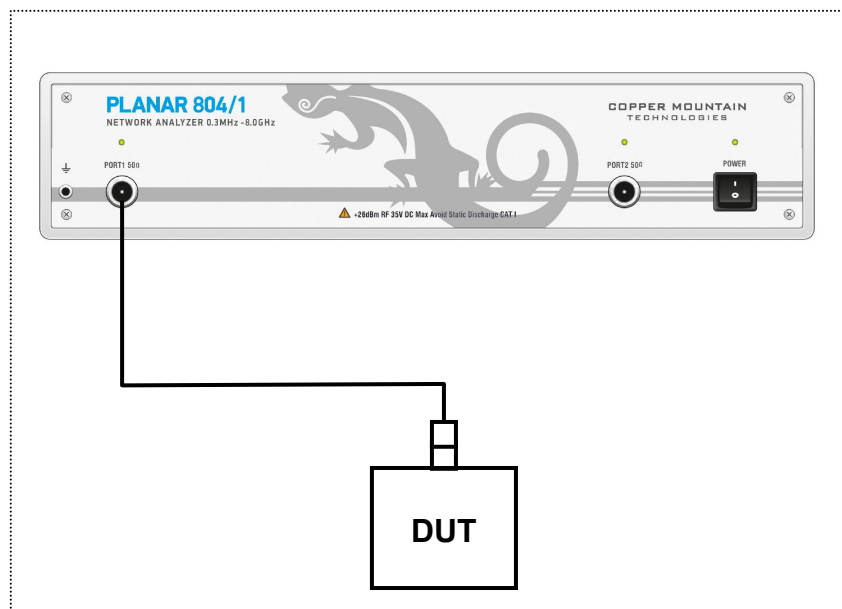

Figure 7 Reflection measurement circuit

To measure SWR and reflection coefficient phases of the DUT, in the given example you should go through the following steps:

- Prepare the Analyzer for reflection measurement;
- Set stimulus parameters (frequency range, number of sweep points);
- Set IF bandwidth;
- Set the number of traces to 2, assign measured parameters and display format to the traces;
- Set the scale of the traces;

- Perform calibration of the Analyzer for reflection coefficient measurement;
- Analyze SWR and reflection coefficient phase using markers.

---

Note	In this section the control over Analyzer is performed by the softkeys located in the right-hand part of the screen. The Analyzer also allows the user to perform quick control by the mouse (See section 4.3).
------	---

---

### 3.1 Analyzer Preparation for Reflection Measurement

Turn on the Analyzer and warm it up for the period of time stated in its specifications.

---

Ready state features	The bottom line of the screen displays the instrument status bar. It should read <b>Ready</b> . Above this bar, the channel status bar is located. The sweep indicator in the left-hand part of this bar should display a progress.
----------------------	---

---

Connect the DUT to Port 1 of the Analyzer. Use the appropriate cables and adapters for connection of the DUT input to the Analyzer test port. If the DUT input is type-N (male), you can connect the DUT directly to the port.

### 3.2 Analyzer Presetting

Before you start the measurement session, it is recommended to reset the Analyzer into the initial (known) condition. The initial condition setting is described in Appendix 1.

---



	<p>To restore the initial condition of the Analyzer, use the following softkeys:</p> <p><b>System &gt; Preset &gt; OK</b></p>
---	---

---

### 3.3 Stimulus Setting

After you have restored the preset state of the Analyzer, the stimulus parameters will be as follows: full frequency range of the instrument, sweep type is linear, number of sweep points is 201, and power level is 0 dBm.

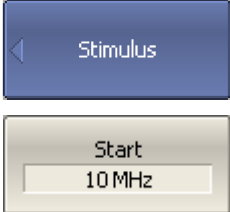
For the current example, set the frequency range to from 10 MHz to 3 GHz.

	<p>To set the start frequency of the frequency range to 10 MHz, use the following softkeys:</p> <p><b>Stimulus &gt; Start</b></p> <p>Then enter «1», «0» from the keyboard. Complete the setting by pressing «M» key.</p>
	<p>To set the stop frequency of the frequency range to 3 GHz, use the following softkeys:</p> <p><b>Stimulus &gt; Stop</b></p> <p>Then enter «3» from the keyboard. Complete the setting by pressing «G» key.</p>
<p>To return to the main menu, click the top softkey (colored in blue).</p>	

### 3.4 IF Bandwidth Setting

For the current example, set the IF bandwidth to 3 kHz.

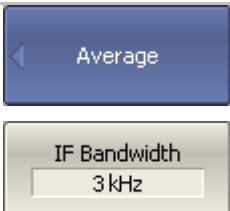
	<p>To set the IF bandwidth to 3 kHz, use the following softkeys:</p> <p><b>Average &gt; IF Bandwidth</b></p> <p>Then enter «3» from the keyboard and complete the setting by pressing «k» key.</p>
<p>To return to the main menu, click the top softkey (colored in blue).</p>	

### 3.5 Number of Traces, Measured Parameter and Display Format Setting

In the current example, two traces are used for simultaneous display of the two parameters (SWR and reflection coefficient phase).



To set the number of traces, use the following softkeys:

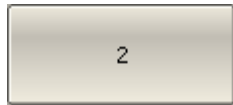

**Display > Num of Traces > 2**

To return to the main menu, click the top softkey (colored in blue).

Before assigning the measurement parameters of a trace, first activate the trace.

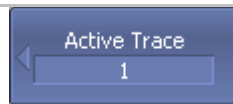

To activate the second trace, use the following softkeys:

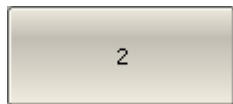

**Display > Active Trace/Channel > Active Trace > 2**

To return to the main menu, click the top softkey (colored in blue).

Assign  $S_{11}$ -parameter to the second trace. To the first trace this parameter is already assigned by default.



To assign a parameter to the trace, use the following softkeys:

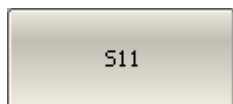

**Measurement > S11**

Then assign SWR display format to the first trace and reflection coefficient phase display format to the second trace.



To set the active trace display format, use the following softkeys:

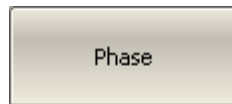

**Format > SWR** (for the first trace),

**Format > Phase** (for the second trace).



To return to the main menu, click the top softkey (colored in blue).

### 3.6 Trace Scale Setting

For convenience of operation, change the trace scale using automatic scaling function.



To set the scale of the active trace by the autoscaling function, use the following softkeys:

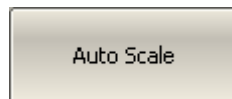

**Scale > Auto Scale**

To return to the main menu, click the top softkey (colored in blue).

### 3.7 Analyzer Calibration for Reflection Coefficient Measurement

Calibration of the whole measurement setup—which includes the Analyzer, cables and other devices involved with connection to the DUT—allows for considerably enhancing the accuracy of the measurement.

To perform full 1-port calibration, you need to prepare the kit of calibration standards: OPEN, SHORT and LOAD. Such a kit has its description and specifications of the standards. To perform proper calibration, you need to select the correct kit type in the program.

To perform the process of full 1-port calibration, connect calibration standards to the test port one after another, as shown in Figure 8.



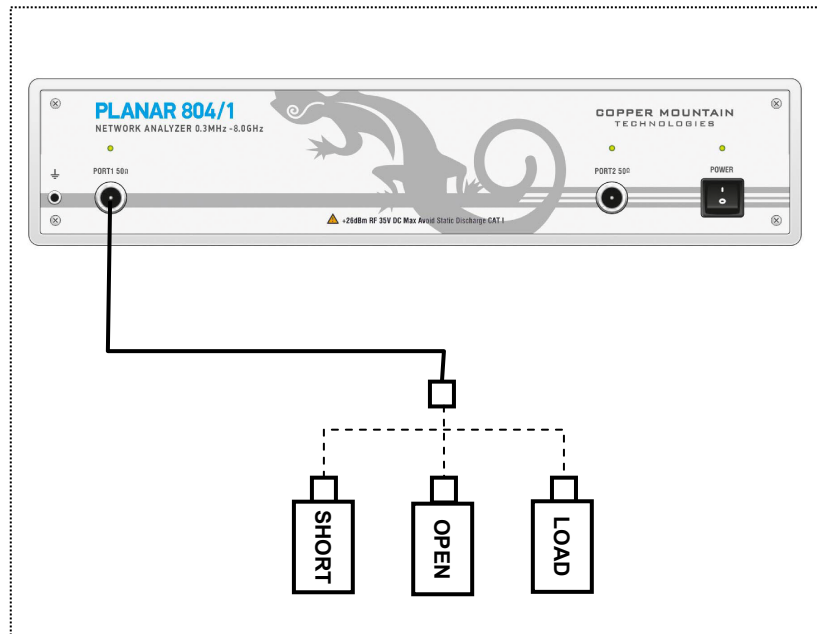
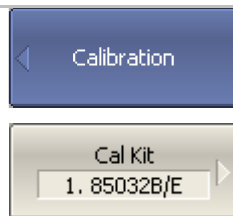

Figure 8 Full 1-port calibration circuit

In the current example, an Agilent 85032E calibration kit is used.



To select the calibration kit, use the following softkeys:

**Calibration > Cal Kit**

Then select the kit you are using from the table at the bottom of the screen.

To perform full 1-port calibration, you will execute measurements of the three standards in turn. After completion, the table of calibration coefficients will be calculated and saved into the memory of the Analyzer. Before you start calibration, disconnect the DUT from the Analyzer.



To perform full 1-port calibration, use the following softkeys:

**Calibration > Calibrate > Full 1-Port Cal**

Connect an OPEN standard and click **Open**.

Connect a SHORT standard and click **Short**.

Connect a LOAD standard and click **Load**.

To complete the calibration procedure and calculate the table of calibration coefficients, click the **Apply** softkey.

## 3.8

### 3.9 SWR and Reflection Coefficient Phase Analysis Using Markers

This section describes how to determine the measurement values at three frequency points using markers. The Analyzer screen view is shown in Figure 9. In the current example, a reflection standard of SWR = 1.2 is used as a DUT.

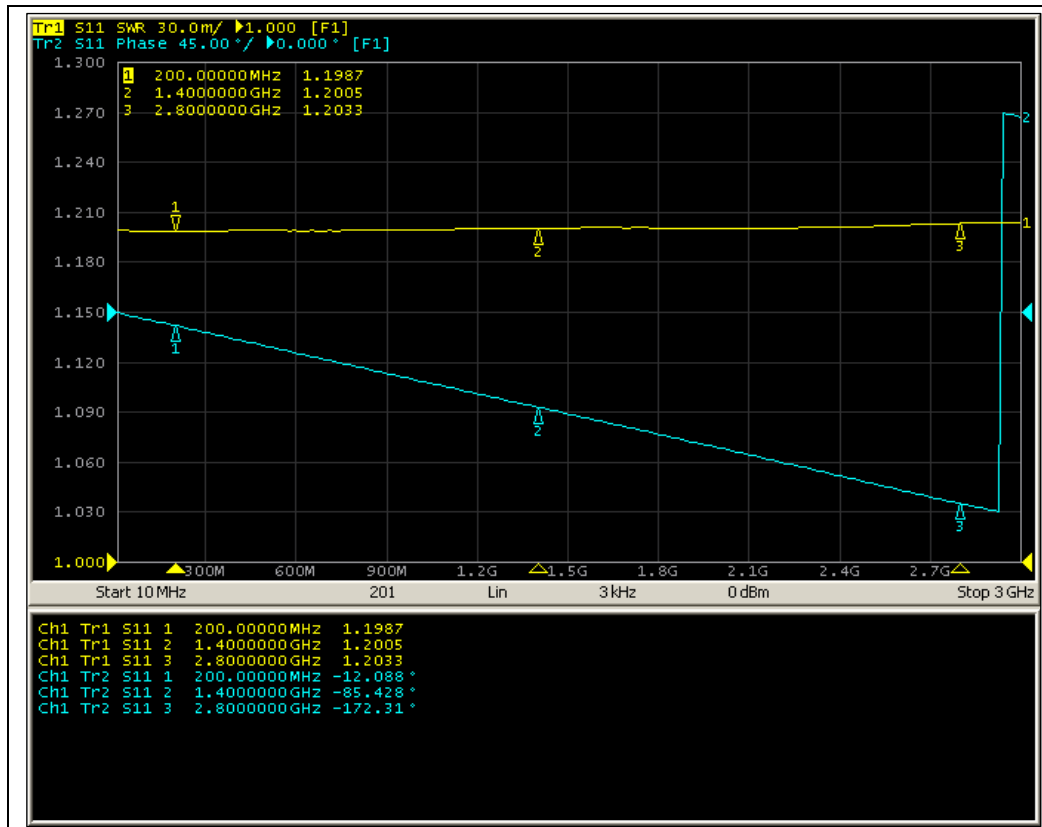
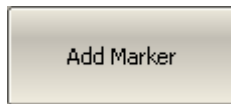

Figure 9 SWR and reflection coefficient phase measurement example



To create a new marker, use the following softkeys:

**Markers > Add Marker**

Then enter the frequency value in the input field in the graph, e.g. to enter frequency 200 MHz, press «2», «0», «0» and «M» keys on the keypad.

---

Repeat the above procedure three times to enable three markers at different frequency points.

---

By default only active trace markers are displayed on the screen. To enable display of two traces simultaneously, activate the marker table.

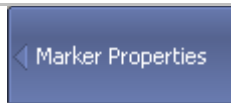

To open the marker table, use the following softkeys:

**Markers > Properties > Marker Table**

## 4 SETTING MEASUREMENT CONDITIONS

### 4.1 Screen Layout and Functions

The screen layout is represented in Figure 10. In this section you will find detailed descriptions of the softkey menu bar, menu bar, and instrument status bar. The channel windows are described elsewhere in this manual.

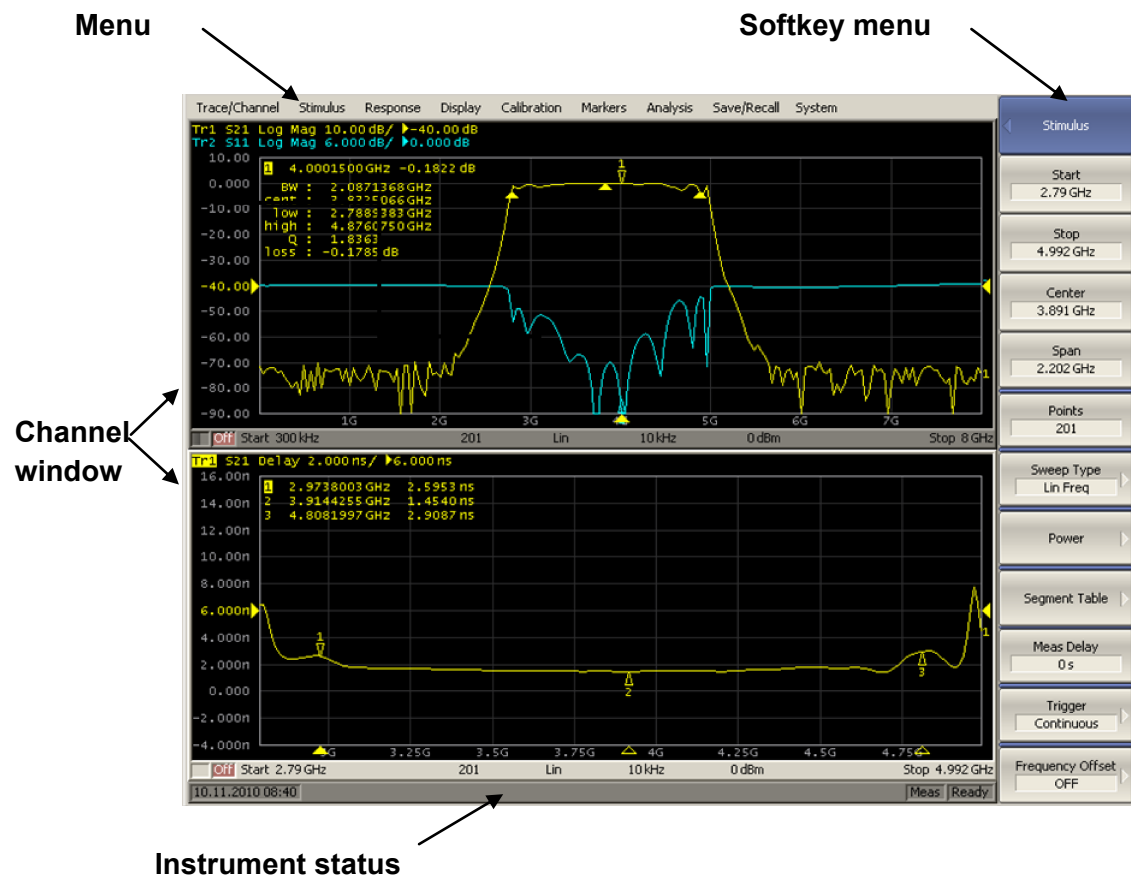

Figure 10 Analyzer screen layout

#### 4.1.1 Softkey Menu Bar

The softkey menu bar along the right side of the screen is the main menu of the program.

---

#### Note

The top line of the screen contains the menu bar, which provides direct access to certain submenus of the softkey menu. This is a secondary menu which can optionally be hidden.





---

The softkey menu bar consists of a series of panels. Each panel represents one of the submenus of the softkey menu. All the panels are integrated to form the complete multilevel menu system, providing access to all the Analyzer functions.

You can navigate the menu softkeys using a mouse.

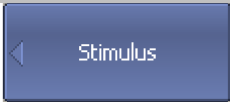
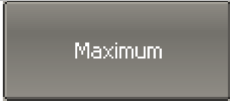
Alternatively you can navigate the menu using the «↑», «↓», «←», «→», «Enter», «Esc», and «Home» keys on an external keyboard.

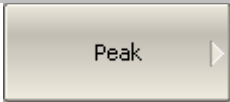
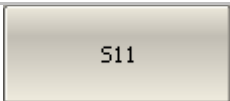
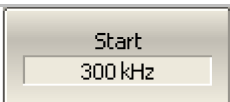
The types of softkeys are described below:

	The top softkey is the menu title key. It enables you to return to a higher level of the menu. If it is displayed in blue, you can use the keyboard to navigate within the softkey menu.
	If the softkey is highlighted in dark gray, pressing «Enter» key on the keyboard will activate the function of this softkey. You can shift the highlight from key to key using «↑» and «↓» arrows on the keyboard.
	A large dot on the softkey indicates the current selection in a list of alternative settings.
	A check mark in the left part of the softkey indicates an active function, which you can switch on/off.
	Softkeys with right arrows provide access to a lower level menu.
	A softkey with a text field allows for the selected function indication.
	Softkeys with a value field allow for entering/selection of the numerical settings.
	This navigation softkey appears when the softkey menu overflows the menu screen area. Using this softkey you can scroll down and up the softkey menu.

To navigate in the softkey menu, you can also (additionally to «↑», «↓») use «←», «→», «Esc», «Home» keys of the keyboard:

- «←» key brings up the upper level of the menu;
- «→» key brings up the lower level of the menu, if there is a highlighted softkey with a right arrow;
- «Esc» key functions similarly to the «←» key;
- «Home» key brings up the main menu.

---

Note	The above keys of the keyboard allow navigation within the softkey menu only if there is no active entry field. In this case the menu title softkey is highlighted in blue.
------	---

---

#### 4.1.2 Menu Bar

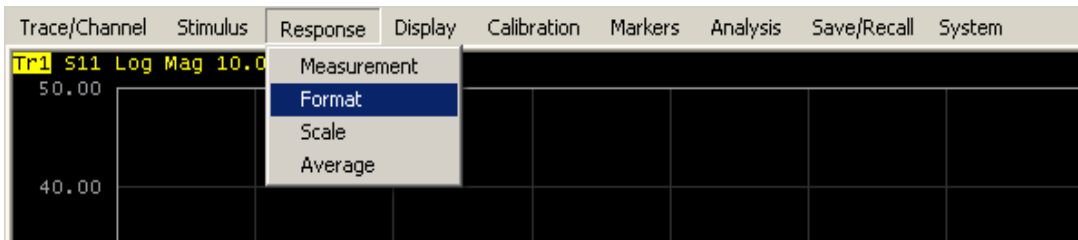

Figure 11 Menu bar

The menu bar is located at the top of the screen. This is a secondary menu providing direct access to certain submenus of the main menu. It also contains the most frequently used softkeys' functions. You can optionally hide the menu bar to gain more screen space for the graph area. The menu bar is controlled by mouse.

---

Note	To hide the menu bar, use the following softkeys:  <b>Display &gt; Properties &gt; Menu Bar</b>
------	---

---

### 4.1.3 Instrument Status Bar



Figure 12 Instrument status bar

The instrument status bar is located at the bottom of the screen.

Table 1 Messages in the instrument status bar

Field Description	Message	Instrument Status
DSP status	<b>Not Ready</b>	No communication between DSP and computer.
	<b>Loading</b>	DSP program is loading.
	<b>Ready</b>	DSP is running normally.
Sweep status	<b>Meas</b>	A sweep is in progress.
	<b>Hold</b>	A sweep is on hold.
	<b>Ext</b>	Waiting for “External” trigger.
	<b>Man</b>	Waiting for “Manual” trigger.
	<b>Bus</b>	Waiting for “Bus” trigger.
Calibration	<b>Calibration...</b>	Calibration standard measurement is in progress.
RF signal	<b>RF output Off</b>	Stimulus signal output is turned off.
External reference frequency	<b>ExtRef</b>	External reference frequency input (10 MHz) is turned on.
Display update	<b>Update Off</b>	Display update is turned off.
System correction status	<b>Sys Corr OFF</b>	System correction is turned off (see section 8.4).
Factory calibration error	<b>PC Error</b>	ROM error of power calibration.
	<b>RC Error</b>	ROM error of system calibration.
External power meter status	<b>Power Meter: message</b>	When external power meter is connected to the Analyzer via USB the following messages are displayed: <b>connection, connection error, ready, measurement, zero setting, zero setting error</b>

## 4.2 Channel Window Layout and Functions

The channel windows display measurement results in the form of traces and numerical values. The screen can display up to 16 channel windows simultaneously. Each window corresponds to one logical channel. A logical channel can be considered to be a separate analyzer with the following settings:

- Stimulus signal settings (frequency range, power level, sweep type);
- IF bandwidth and averaging;
- Calibration.

The physical analyzer processes the logical channels sequentially.

In turn, each channel window can display up to 16 trace of measured parameters. The general view of the channel window is represented in Figure 13.

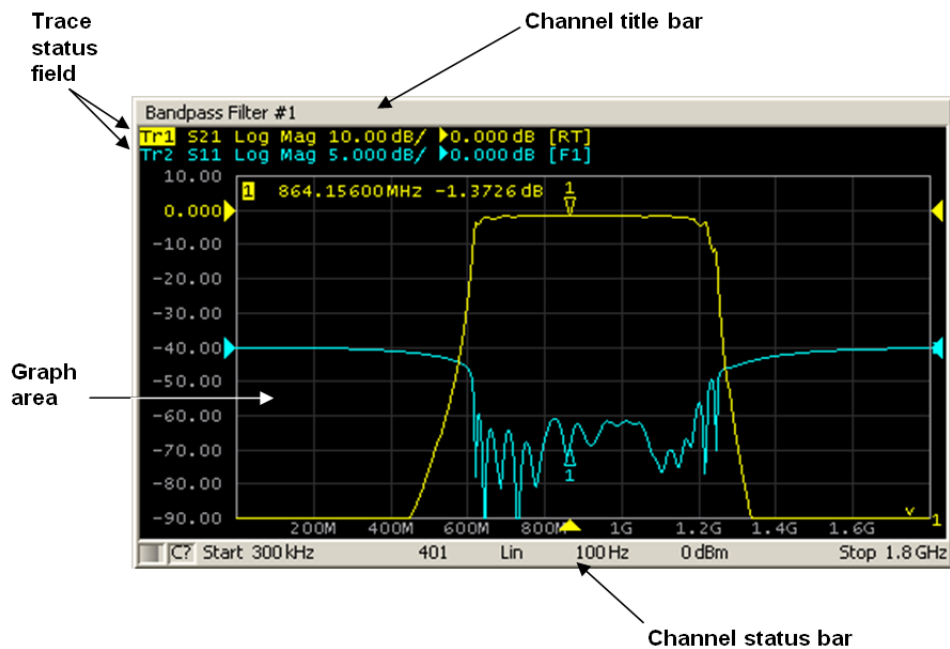

Figure 13 Channel window



## 4.2.1 Channel Title Bar

The channel title feature allows you to enter your comment for each channel window. You can hide the channel title bar to gain more screen space for graph area.

---

Channel title bar on/off switching	To show/hide the channel title bar, use the following softkeys:  <b>Display &gt; Title Label</b>
Channel title editing	You can access the channel title edit mode by using the following softkeys:  <b>Display &gt; Edit Title Label</b>  Alternatively, mouse click on the title area in the channel title bar.

---

## 4.2.2 Trace Status Field

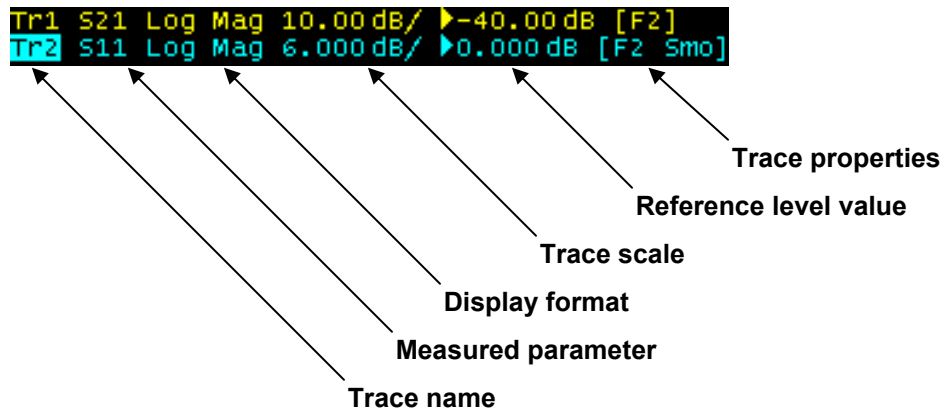

Figure 14 Trace status field

The trace status field displays the name and parameters of a trace. The number of lines in the field depends on the number of active traces in the channel.

---

Note	Using the trace status field you can easily modify the trace parameters using the mouse (as described in section 4.3).
------	--

---

Each line contains the data of one trace of the channel:

- Trace name from «Tr1» to «Tr16». The active trace name is highlighted in an inverted color;
- Measured parameter: **S11**, **S21**, **S12**, **S22**, or absolute power value: **A(n)**, **B(n)**, **R1(n)**, **R2(n)**;
- Display format, e.g. «Log Mag»;
- Trace scale in measurement units per scale division, e.g. «10.0 dB/»;
- Reference level value, e.g. «▶0.00 dB», where «▶» is the symbol of the reference level;
- Trace status is indicated as symbols in square brackets (See Table 2).

Table 2 Trace status symbols definition

Status	Symbols	Definition
Error Correction	<b>RO</b>	OPEN response calibration
	<b>RS</b>	SHORT response calibration
	<b>RT</b>	THRU response calibration
	<b>OP</b>	One-path 2-port calibration
	<b>F1</b>	Full 1-port calibration
	<b>F2</b>	Full 2-port and TRL calibration
	<b>SMC</b>	Scalar mixer calibration
Other Calibrations	<b>RC</b>	Receiver calibration
	<b>PC</b>	Power calibration
Data Analysis	<b>Z0</b>	Port impedance conversion
	<b>FD</b>	Fixture de-embedding
	<b>FE</b>	Fixture embedding
	<b>PExt</b>	Port extension
Trace Display	No indication	Data trace
	<b>D&amp;M</b>	Data and memory traces
	<b>M</b>	Memory trace
	<b>Off</b>	Data and memory traces – off
Math Operations	<b>D+M</b>	Data + Memory
	<b>D-M</b>	Data – Memory
	<b>D*M</b>	Data * Memory
	<b>D/M</b>	Data / Memory
Electrical Delay	<b>Del</b>	Electrical delay other than zero
Smoothing	<b>Smo</b>	Trace smoothing
Gating	<b>Gat</b>	Time domain gating
Conversion	<b>Zr</b>	Reflection impedance
	<b>Zt</b>	Transmission impedance
	<b>Yr</b>	Reflection admittance
	<b>Yt</b>	Transmission admittance
	<b>1/S</b>	S-parameter inversion
	<b>Ztsh</b>	Transmission-shunt impedance
	<b>Ytsh</b>	Transmission-shunt admittance
	<b>Conj</b>	Conjugation

### 4.2.3 Graph Area

The graph area displays traces and numeric data.

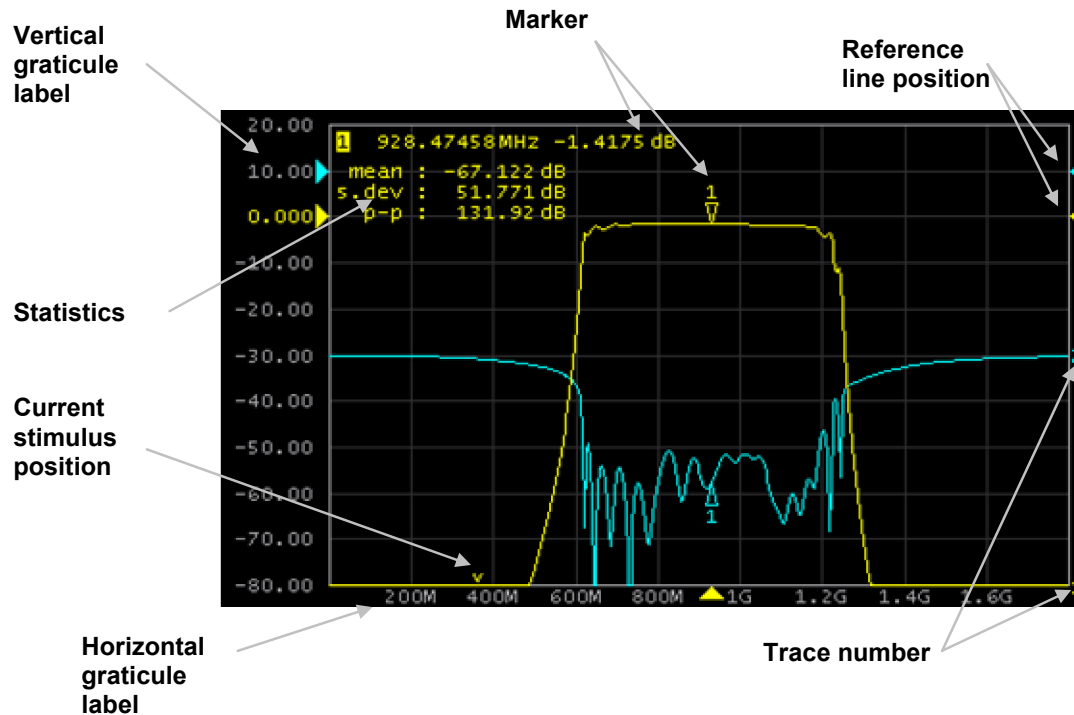

Figure 15 Graph area

The graph area contains the following elements:

- *Vertical graticule label* displays the vertical axis numeric data for the active trace. You can set the display of data for all the traces or hide the vertical graticule label to gain more screen space for the trace display.
- *Horizontal graticule label* displays stimulus axis numeric data (frequency, power level or time). You can also hide the horizontal graticule label to gain more screen space for the trace display.
- *Reference level position* indicates the reference level position of the trace.
- *Markers* indicate the measured values at points along the active trace. You can simultaneous display of markers for all traces.
- Marker functions: *statistics, bandwidth, flatness, RF filter*.

- *Trace number* allows trace identification when printing in black and white.
- *Current stimulus position* indicator appears when sweep duration exceeds 1.5 sec.

---

Note Using the graticule labels, you can easily modify all the trace parameters using the mouse (as described in section 4.3).

---

#### 4.2.4 Trace Layout in Channel Window

If the number of the displayed traces is more than one, you can rearrange the traces to suit your preference. You can allocate all the traces to one graph (See Figure 15) or display of each trace in an individual graph (See Figure 16).

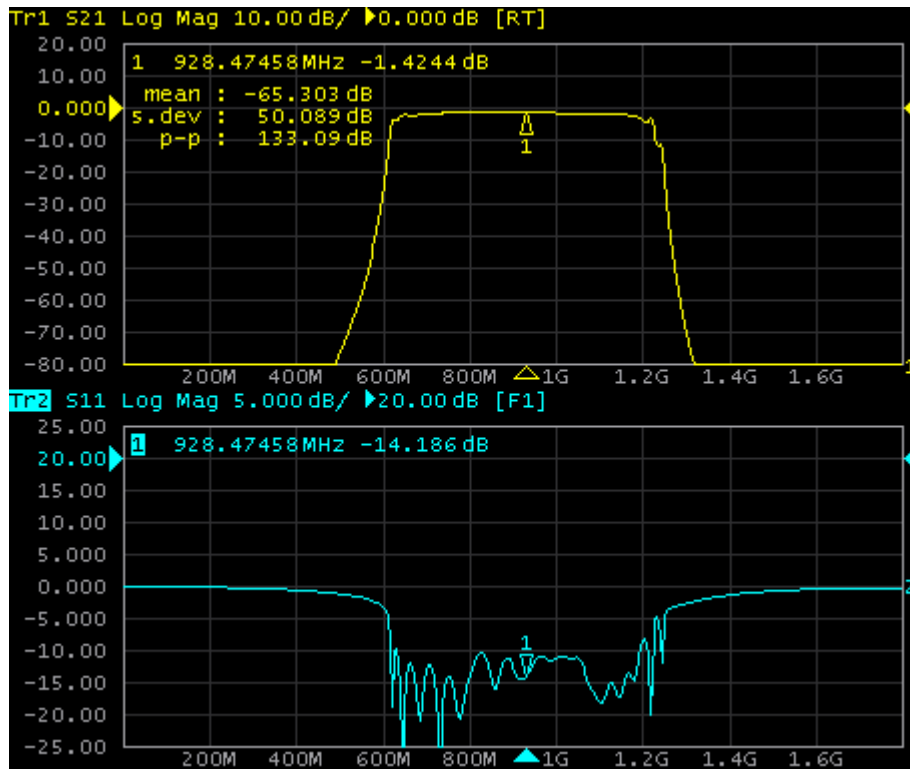

Figure 16 Two traces in one channel window (sample)

## 4.2.5 Markers

The markers indicate the stimulus values and the measured values at selected points of the trace (See Figure 17).

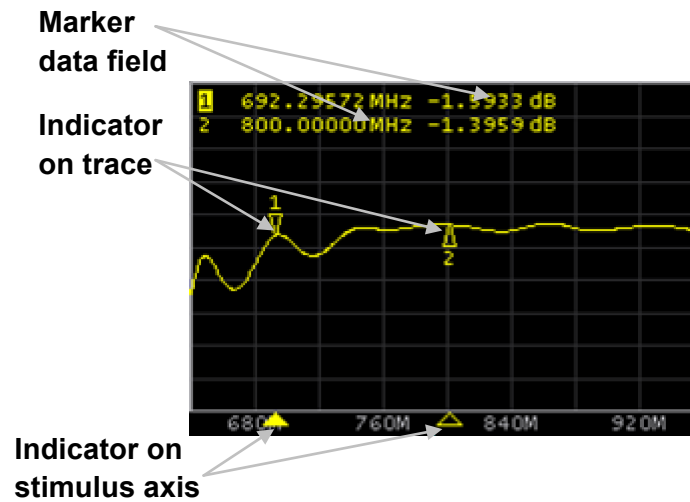

Figure 17 Markers

The markers are numbered from 1 to 15. The reference marker is indicated with an R symbol. The active marker is indicated in the following manners: its number is highlighted with inverse color, the indicator on the trace is located above the trace, and the stimulus indicator is fully colored.

## 4.2.6 Channel Status Bar

The channel status bar is located in the bottom part of the channel window. It contains the following elements:

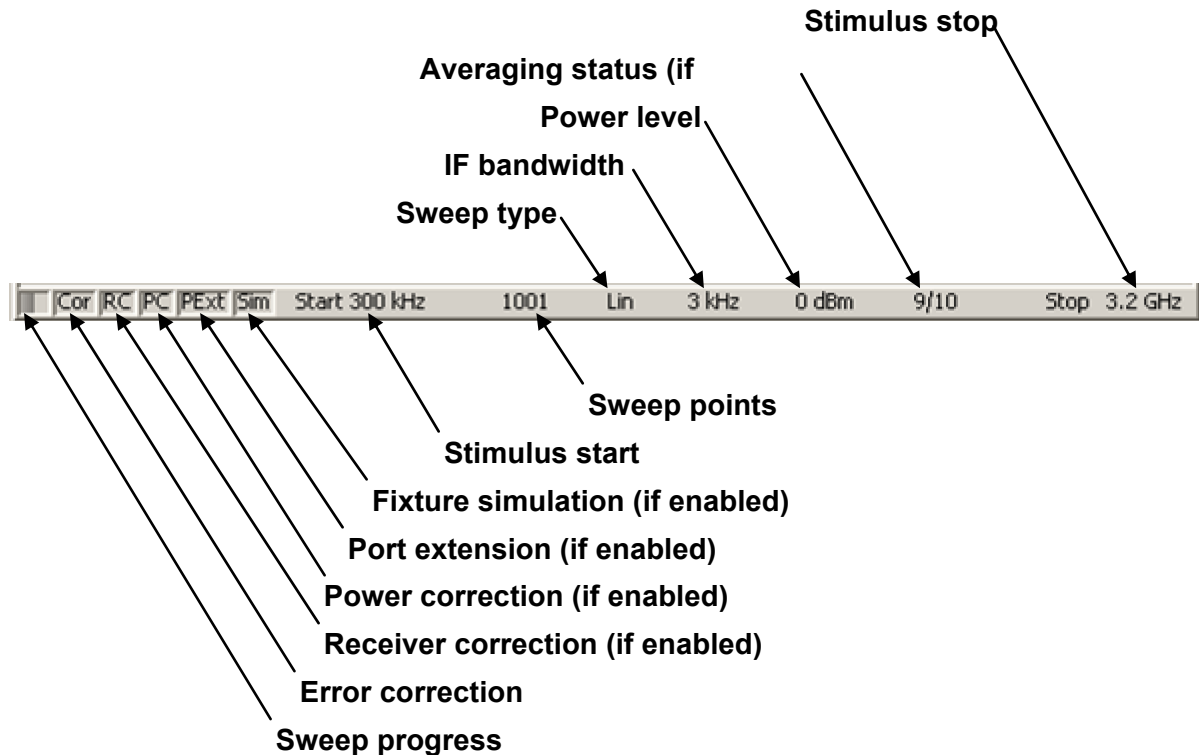

Figure 18 Channel status bar

- *Sweep progress* field displays a progress bar when the channel data are being updated.
- *Error correction* field displays the integrated status of error correction for S-parameter traces. The values of this field are represented in Table 3.
- *Receiver correction* field displays the integrated status of receiver correction for absolute power measurement traces. The values of this field are represented in Table 4.
- *Power correction* field displays the integrated status of power correction for all the traces. The values of this field are represented in Table 5.
- *Port extension* field displays the integrated status of execution of this function for S-parameter traces. If the function is enabled for all the traces, you will see black characters on a gray

background. If the function is enabled just for some of the traces, you will see white characters on a red background.

- *Fixture simulation* field displays the integrated status of execution of this function for S-parameter traces. Fixture simulation includes the following operations: Z0 conversion, embedding, and de-embedding. If the function is enabled for all the traces, you will see black characters on a gray background. If the function is enabled just for some of the traces, you will see white characters on a red background.
- *Stimulus start* field allows for display and entry of the start frequency or power, depending on the sweep type. This field can be switched to indication of stimulus center frequency, in this case the word **Start** will change to **Center**.
- *Sweep points* field allows for display and entry of the number of sweep points. The number of sweep points can be set from 2 to the instrument maximum.
- *Sweep type* field allows for display and selection of the sweep type. The values of this field are represented in Table 6.
- *IF bandwidth* field allows for display and setting of the IF bandwidth. The values can be set from the instrument minimum to 30 kHz.
- *Power level* field allows for display and entry of the port output power. In power sweep mode the field switches to indication of CW frequency of the source.
- *Averaging status* field displays the averaging status if this function is enabled. The first number is the averaging current counter value, the second one is the averaging factor.
- *Stimulus stop* field allows for display and entry of the stop frequency or power, depending on the sweep type. This field can be switched to indication of stimulus span, in this case the word **Stop** will change to **Span**.



Table 3 Error correction field

Symbol	Definition	Note
<b>Cor</b>	Error correction is enabled. The stimulus settings are the same for the measurement and the calibration.	If the function is active for all the traces – black characters on a gray background.
<b>C?</b>	Error correction is enabled. The stimulus settings are not the same for the measurement and the calibration. Interpolation is applied.	
<b>C!</b>	Error correction is enabled. The stimulus settings are not the same for the measurement and the calibration. Extrapolation is applied.	If the function is active only for some of the traces (other traces are not calibrated) – white characters on a red background.
<b>Off</b>	Error correction is turned off.	For all the traces. White characters on a red background.
---	No calibration data. No calibration was performed.	

Table 4 Receiver correction field

Symbol	Definition	Note
<b>RC</b>	Receiver correction is enabled. The stimulus settings are the same for the measurement and the calibration.	If the function is active for all the traces – black characters on a gray background.
<b>RC?</b>	Receiver correction is enabled. The stimulus settings are not the same for the measurement and the calibration. Interpolation is applied.	
<b>RC!</b>	Receiver correction is enabled. The stimulus settings are not the same for the measurement and the calibration. Extrapolation is applied.	If the function is active only for some of the traces (other traces are not calibrated) – white characters on a red background.

Table 5 Power correction field

Symbol	Definition	Note
<b>PC</b>	Power correction is enabled. The stimulus settings are the same for the measurement and the calibration.	If the function is active for all the traces – black characters on a gray background.  If the function is active only for some of the traces (other traces are not calibrated) – white characters on a red background.
<b>PC?</b>	Power correction is enabled. The stimulus settings are not the same for the measurement and the calibration. Interpolation is applied.	
<b>PC!</b>	Power correction is enabled. The stimulus settings are not the same for the measurement and the calibration. Extrapolation is applied.	

Table 6 Sweep types

Symbol	Definition
<b>Lin</b>	Linear frequency sweep.
<b>Log</b>	Logarithmic frequency sweep.
<b>Segm</b>	Segment frequency sweep.
<b>Pow</b>	Power sweep.

### 4.3 Quick Channel Setting Using a Mouse

This section describes mouse operations which enable you to set the channel parameters quickly and easily. In a channel window, when hovering over the field where a channel parameter can be modified, the mouse pointer will change its icon to indicate edit mode. In text and numerical fields, edit mode will be indicated by underline «underline» symbol appearance.

Note	The mouse operations described in this section will help you adjust the most frequently used settings. The complete set of channel functions can be accessed via the softkey menu.
------	--

#### 4.3.1 Active Channel Selection

You can select the active channel when two or more channel windows are open. The border line of the active window will be highlighted in a light color. To activate another window, click inside its area.

#### 4.3.2 Active Trace Selection

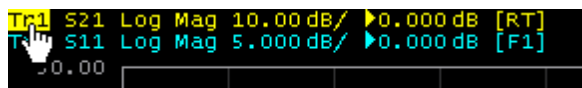

You can select the active trace if the active channel window contains two or more traces. The active trace name will be highlighted in inverted color. To activate a trace, click on the required trace status line, or on the trace curve or the trace marker.

#### 4.3.3 Measured Data Setting

To assign the measured parameters ( $S_{11}$ ,  $S_{21}$ ,  $S_{12}$  or  $S_{22}$ ) to a trace, click on the S-parameter name in the trace status line and select the required parameter in the drop-down menu.

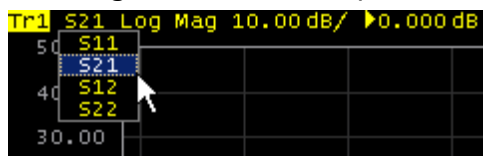

#### 4.3.4 Display Format Setting

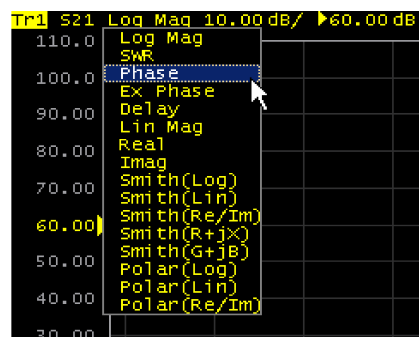

To select the trace display format, click on the display format name in the trace status line and select the desired format in the drop-down menu.

### 4.3.5 Trace Scale Setting

The trace scale, also known as the vertical scale division value, can be set by either of two methods.



The first method: click on the trace scale field in the trace status line and enter the required numerical value.

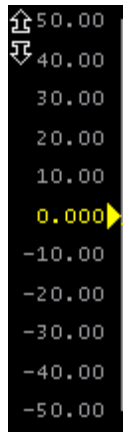

The second method: move the mouse pointer over the vertical scale until the pointer icon becomes as shown in the figure. The pointer should be placed in the top or bottom parts of the scale, at approximately 10% of the scale height from the top or bottom of the scale. Left click and drag away from the scale center to enlarge the scale, or toward the scale center to reduce the scale.

### 4.3.6 Reference Level Setting

The value of the reference level, which is indicated on the vertical scale by the «▶» and «◀» symbols, can be set by either of two methods.

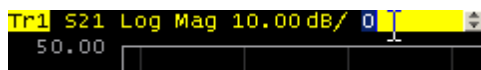

The first method: click on the reference level field in the trace status line and enter the required numerical value.



The second method: move the mouse pointer over the vertical scale until the pointer icon becomes as shown in the figure. The pointer should be placed in the center part of the scale. Left click and drag up to increase the reference level value, or down to reduce the value.

### 4.3.7 Reference Level Position



The reference level position, indicated on the vertical scale by «►» and «◀» symbols, can be set in the following way. Locate the mouse pointer on a reference level symbol until it becomes as shown in the figure. Then drag and drop the reference level symbol to the desired position.

### 4.3.8 Sweep Start Setting



Move the mouse pointer over the stimulus scale until it becomes as shown in the figure. The pointer should be placed in the left part of the scale, at approximately 10% of the scale length from the left. Left click and drag right to increase the sweep start value, or left to reduce the value.

### 4.3.9 Sweep Stop Setting



Move the mouse pointer over the stimulus scale until it becomes as shown in the figure. The pointer should be placed in the right part of the scale, at approximately 10% of the scale length from the right. Left click and drag right to increase the sweep stop value, or left to reduce the value.

### 4.3.10 Sweep Center Setting



Move the mouse pointer over the stimulus scale until it becomes as shown in the figure. The pointer should be placed in the center part of the scale. Left click and drag right to increase the sweep center value, or left to reduce the value.

### 4.3.11 Sweep Span Setting



Move the mouse pointer over the stimulus scale until it becomes as shown in the figure. The pointer should be placed in the center part of the scale, at approximately 20% of the scale length from the right. Left click and drag to the right to increase the sweep span value, or to the left to reduce the value.

### 4.3.12 Marker Stimulus Value Setting

The marker stimulus value can be set by either a click and drag operation, or by entering the value using numerical keys of the keyboard.

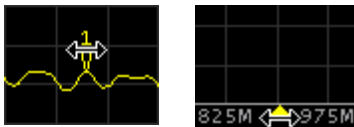

To drag the marker, first move the mouse pointer on one of the marker indicators until it becomes as shown in the figures.

To enter the numerical value of the stimulus, first activate its field by clicking it in the marker data line.

### 4.3.13 Switching between Start/Center and Stop/Span Modes



To switch between the modes Start/Center and Stop/Span, click on the respective field of the channel status bar. Clicking the label **Start** changes it to **Center**, and the label **Stop** will change to **Span**. The layout of the stimulus scale will be changed correspondingly.

### 4.3.14 Start/Center Value Setting



To enter the **Start/Center** values, activate the respective field in the channel status bar by clicking the numerical value.

### 4.3.15 Stop/Span Value Setting



To enter the **Stop/Span** values, activate the respective field in the channel status bar by clicking the numerical value.

### 4.3.16 Sweep Points Number Setting



To enter the number of sweep points, activate the respective field in the channel status bar by clicking the numerical value.

### 4.3.17 Sweep Type Setting

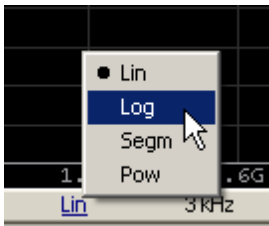

To set the sweep type, left click on the respective field in the channel status bar and select the required type in the drop-down menu.

### 4.3.18 IF Bandwidth Setting

IF bandwidth can be set by selection in the drop-down menu or by entering the value using numerical keys of the keyboard.

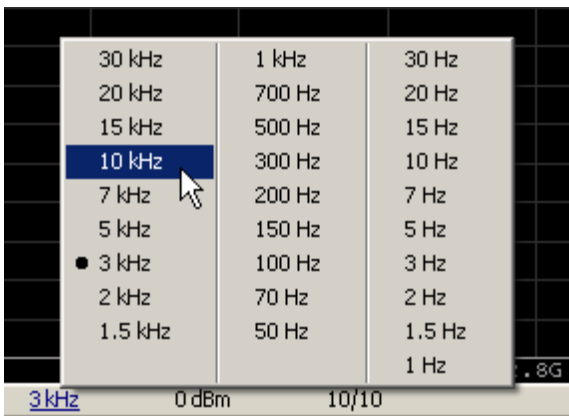

To activate the drop-down menu, right click on the IF bandwidth field in the channel status bar.



To enter the IF bandwidth, activate the respective field in the channel status bar by left clicking.

### 4.3.19 Power Level / CW Frequency Setting



To enter the **Power Level/CW Frequency**, activate the respective field in the channel status bar by clicking the numerical value. The parameter displayed in the field depends on the current sweep type: in frequency sweep mode you can enter the power level value, in power sweep mode you can enter the CW frequency value.

## 4.4 Channel and Trace Display Setting

The Analyzer supports 16 channels, each of which allows for measurements with stimulus parameter settings different from the other channels. The parameters related to a logical channel are listed in Table 7.

### 4.4.1 Channel Allocation

A channel is represented on the screen as an individual channel window. The screen can display from 1 to 16 channel windows simultaneously. By default one channel window opens. If you need to open two or more channel windows select one of the layouts shown below.

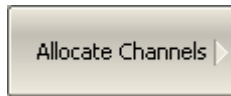
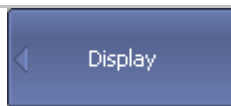

To set the channel window layout, use the following softkeys:

**Display > Allocate Channels**

Then select the required number and layout of the channel windows in the menu.

The available options of number and layout of the channel windows on the screen are as follows:

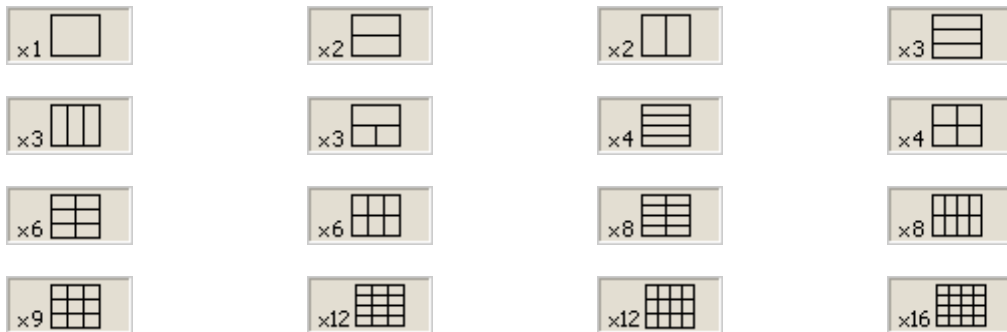

In accordance with the layouts, the channel windows do not overlap each other. The channels open sequentially starting from the smaller numbers.

#### Note

For each open channel window, you should set the stimulus parameters, adjust other settings, and perform calibration.

Before you change a channel parameter setting or perform calibration of a channel, you need to ensure the channel is selected as active.



The measurements are executed for open channel windows sequentially. Measurements for any hidden channel windows are not performed.

#### 4.4.2 Number of Traces

Each channel window can contain up to 16 different traces. Each trace is assigned a measured parameter (S-parameter), display format and other parameters. The parameters related to a trace are listed in Table 8.

Traces can be displayed in one graph, overlapping each other, or in separate graphs within a channel window. The trace settings are made in two steps: trace number and trace layout within the channel window. By default the channel window contains one trace. If you need to enable two or more traces, set the number of traces as described below.

---

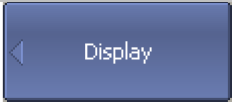
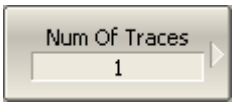
	<p>To set the number of the traces, use the following softkeys:</p>
	<p><b>Display &gt; Num Of Traces</b></p> <p>Then select the number of traces from the menu.</p>

---

All traces are assigned individual names, which cannot be changed. The trace name contains its number. The trace names are as follows: **Tr1, Tr2 ... Tr16**.

Each trace is assigned some initial settings: measured parameter, format, scale, and color, which can be modified by the user.

- The measured parameters of the first four traces default to the following values:  $S_{11}$ ,  $S_{21}$ ,  $S_{12}$ ,  $S_{22}$ . After that the measurement defaults repeat in cycles.
- By default the display format for all the traces is set to logarithmic magnitude (dB).
- The scale parameters by default are set as follows: division is set to 10 dB, reference level value is set to 0 dB, and the reference level position is in the middle of the graph.
- The trace color is determined by its number. You can change the color for all the traces having the same number.

---

Note	The full cycle of trace update depends on the S-parameters measured and the calibration method. For example, the full cycle might consist of a single sweep with either Port 1 or Port 2 as the source, or might include two successive sweeps, of Port 1 then of Port 2. To have two traces ( $S_{11}$ and $S_{22}$ ) measured, two successive sweeps will be performed. Two successive sweeps are also performed when full 2-port calibration is employed, independently of the number of the traces and S-parameters measured.
------	---

---

### 4.4.3 Trace Allocation

By default traces are displayed overlapping one other in the channel window. If you wish to display the traces in separate graphs, set the number and layout of the graphs in the channel window as shown below.

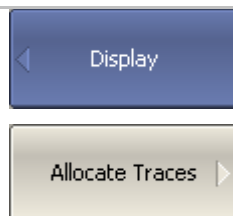

To allocate the traces in a channel window, use the following softkeys:

**Display > Allocate Traces**

Then select the desired number and layout of the separate trace graphs in the menu.

The available options of number and layout of the trace graphs of one channel window are as shown in section 4.4.1.

---

Unlike channel windows, the number of traces and their allocation into a number of graphs can be set independently.

- If the number of traces and the number of graphs are equal, all the traces will be displayed separately, each in its individual graph.
- If the number of traces is greater than the number of graphs, traces will be assigned successively (beginning from the smallest trace number) to the number of available graphs. When all the graphs are utilized, the process will continue from the first graph (the following in succession traces will be added in the graphs).

- If the number of traces is smaller than the number of graphs, empty graphs will be displayed.

If two or more traces are displayed in one graph, the vertical scale will be shown for the active trace.

Note	The Analyzer can optionally show vertical graticule labels for all the traces in the graph. By default this feature is disabled. For details see section 8.6.
------	---

If two or more traces are displayed in one graph, markers data will be shown for the active trace.

Note	To display the marker data for all the traces simultaneously, there are two options: use the marker table feature (See section 6.1.6.2) or deactivate identification of the active trace marker only, which is set by default (See section 6.1.6.4).
------	--

The stimulus axis is the same for all the traces of the channel, except for the case when time domain transformation is applied to some of the traces. In this case the displayed stimulus axis will correspond to the active trace.

Table 7 Channel parameters

N	Parameter Description
1	Sweep Type
2	Sweep Range
3	Number of Sweep Points
4	Stimulus Power Level
5	Power Slope Feature
6	CW Frequency
7	Segment Sweep Table
8	Trigger Mode
9	IF Bandwidth
10	Averaging
11	Calibration
12	Fixture Simulator

Table 8 Trace parameters

N	Parameter Description
1	Measured Parameter (S-parameter)
2	Display Format
3	Reference Level Scale, Value and Position
4	Electrical Delay, Phase Offset
5	Memory Trace, Math Operation
6	Smoothing
7	Markers
8	Time Domain
9	Parameter Transformation
10	Limit Test

#### 4.4.4 Selection of Active Trace/Channel

The control commands selected by the user are applied to the active channel or the active trace, respectively.

The boundary line of the active channel window is highlighted in a light color. The active trace belongs to the active channel and its title is highlighted in an inverse color.

Before you set the parameters of a channel or trace, first you need to activate that channel or trace, respectively.

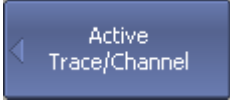
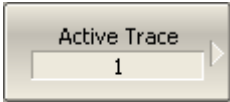
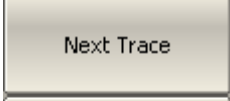
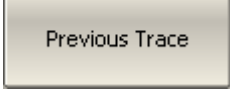
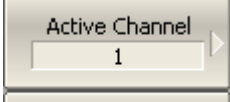
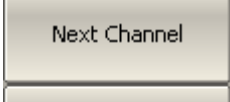
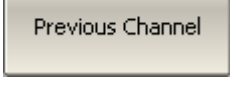
	<p>To activate a trace/channel, use the following softkeys:</p>
	<p><b>Display &gt; Active Trace/Channel</b></p>
	<p>Then activate the trace by entering the number in the <b>Active Trace</b> softkey or using <b>Previous Trace</b> or <b>Next Trace</b> softkeys.</p>
	<p>The active channel can be selected in a similar way.</p>
	
	
	

#### 4.4.5 Active Trace/Channel Window Maximizing

When there are several channel windows displayed, you can temporarily maximize the active channel window to full screen size. The other channel windows will not be visible, but this will not interrupt measurements in those channels.

Similarly, when there are several traces displayed in a channel window, you can temporarily maximize the active trace. The other traces will not be visible, but this will not interrupt measurement of those traces.

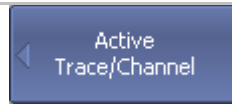

To enable/disable active channel maximizing function, use the following softkeys:

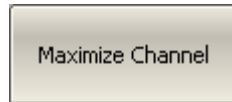

**Display > Active Trace/Channel > Active Channel**

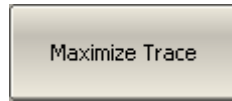

To enable/disable active trace maximizing function, use the following softkeys:

**Display > Active Trace/Channel > Active Trace**

---

Note

Channel and trace maximization can also be controlled achieved by a double click on the channel/trace.

---

## 4.5 Stimulus Setting

The stimulus parameter settings apply to each channel. Before you set the stimulus parameters of a channel, make the channel active.

---

Note	To make maximize measurement accuracy, perform measurements with the same stimulus settings as were used for calibration.
------	---

---

### 4.5.1 Sweep Type Setting



To set the sweep type, use the following softkeys:

**Stimulus > Sweep Type**

Then select the sweep type:

- **Lin Freq:** Linear frequency sweep
- **Log Freq:** Logarithmic frequency sweep
- **Segment:** Segment frequency sweep
- **Power Sweep:** Power sweep

### 4.5.2 Sweep Span Setting

The sweep range should be set for linear and logarithmic frequency sweeps (Hz) and for linear power sweep (dBm). The sweep range can be set as either Start / Stop or Center / Span values of the range.

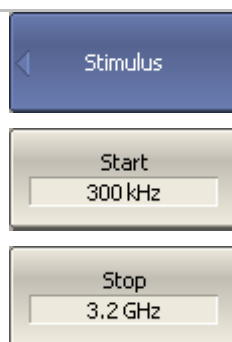

To enter the start and stop values of the sweep range, use the following softkeys:

**Stimulus > Start | Stop**

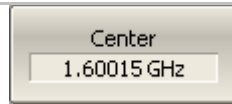

To enter center and span values of the sweep range, use the following softkeys:



**Stimulus > Center | Span**

Note

If power sweep is activated, the values on the **Start**, **Stop**, **Center**, and **Span** softkeys will be represented in **dBm**.

### 4.5.3 Sweep Points Setting

The number of sweep points should be set for linear and logarithmic frequency sweeps, and for linear power sweep.



To enter the number of sweep points, use the following softkeys:

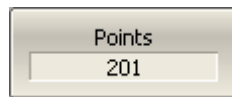

**Stimulus > Points**

### 4.5.4 Stimulus Power Setting

The stimulus power level should be set for linear and logarithmic frequency sweeps. For the segment sweep type, the method of power level setting described in this section can be used only if the same power level is set for all the segments of the sweep. For setting of individual power levels for each segment see section 4.5.9.



To enter the power level value when port couple feature is ON, use the following softkeys:

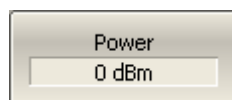



**Stimulus > Power > Power**

### 4.5.5 Setting Power Level for Each Port Individually

By default the power levels of all test ports are set to equal value. This function is called Port Couple. The user can optionally disable this function and set the power level of each port individually.

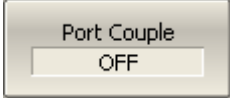

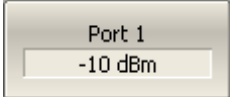
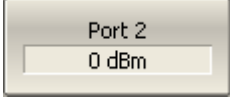
	<p>To set the power level for each port individually, first disable the Power Couple function:</p>
	<p><b>Stimulus &gt; Power &gt; Power Couple [ON   OFF]</b></p>
	<p>Then set the power level for each port:</p>
	<p><b>Stimulus &gt; Power &gt; Port Power &gt; [Port 1   Port 2]</b></p>

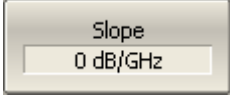
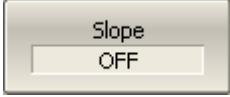

#### 4.5.6 Power Slope Feature

The power slope feature allows for compensation of power attenuation with frequency increase, for example in fixture cabling. The power slope can be set for linear, logarithmic and segment frequency sweep types.

	<p>To enter the power slope value, use the following softkeys:</p>
	<p><b>Stimulus &gt; Power &gt; Slope (dB/GHz)</b></p>
	<p>To enable/disable the power slope function, use the following softkeys:</p>
	<p><b>Stimulus &gt; Power &gt; Slope (On/Off)</b></p>



#### 4.5.7 CW Frequency Setting

CW frequency setting determines the source frequency for linear power sweeps.

	<p>To enter the CW frequency value, use the following softkeys:</p>
	<p><b>Stimulus &gt; Power &gt; CW Freq</b></p>

#### 4.5.8 RF Out Function

The RF Out function allows for temporary disabling of the stimulus signal. While the stimulus is disabled, measurements cannot be performed.

	To disable/enable stimulus, use the following softkeys:
	<b>Stimulus &gt; Power &gt; RF Out</b>

**Note** The RF Out function is applied to the whole Analyzer, not to individual channels. Indication of RF Out status appears in the instrument status bar (See section 4.1.3).

#### 4.5.9 Segment Table Editing

The segment table determines the sweep parameters when segment sweep mode is activated.

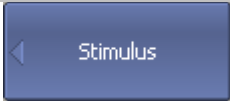
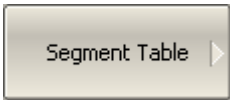
	To open the segment table, use the following softkeys:
	<b>Stimulus &gt; Segment Table</b>

When you switch to the **Segment Table** submenu, the segment table will open in the lower part of the application. When you exit the **Segment Table** submenu, the segment table will be hidden.

The segment table layout is shown below. The table has three mandatory columns: frequency range and number of sweep points, and three columns which you can optionally enable/disable: IF bandwidth, power level and delay time.

	Start	Stop	Points	IFBW	Power
1	300 KHZ	800 MHz	11	100 Hz	10 dBm
2	800 MHz	1.12 GHz	51	3 kHz	0 dBm
3	1.12 GHz	1.99 GHz	101	30 kHz	-10 dBm
4	1.99 GHz	2.28 GHz	51	3 kHz	0 dBm
5	2.28 GHz	3.2 GHz	11	100 Hz	10 dBm

Total Points: 225

Each row describes one segment. The table can contain one or more rows. The number of segments is limited only by the instrument's maximum number of sweep points.

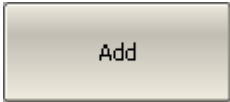
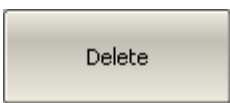
	<p>To add a segment to the table, click <b>Add</b> softkey. The new segment row will be entered below the highlighted one.</p>
	<p>To delete a segment, click <b>Delete</b> softkey. The highlighted segment will be deleted.</p>
	

For any segment it is necessary to set the mandatory parameters: frequency range and number of sweep points. The frequency range can be set either as Start / Stop, or as Center / Span.

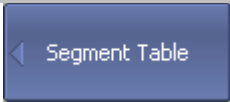
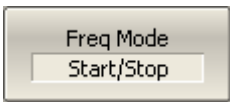
	<p>To set the frequency range representation mode, click <b>Freq Mode</b> softkey to select between <b>Start/Stop</b> and <b>Center/Span</b> options.</p>
	

For any segment you can enable the additional parameter columns: IF bandwidth, power level, and delay time. If such a column is disabled, the corresponding value set for linear sweep will be used (same for all the segments).

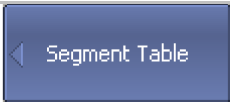
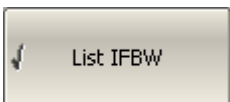
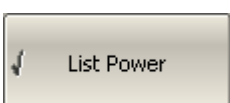
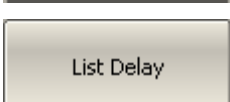
	<p>To enable the IF bandwidth column, click <b>List IFBW</b> softkey.</p>
	<p>To enable the power level column, click <b>List Power</b> softkey.</p>
	<p>To enable the delay time column, click <b>List Delay</b> softkey.</p>
	

To set a parameter, make a mouse click on its value field and enter the value. To navigate in the table you can use the keys of the keyboard.

<p>Note</p>	<p>Adjacent segments must not overlap in the frequency domain.</p>
-------------	--

The segment table can be saved into \*.lim file to a hard disk and later recalled.

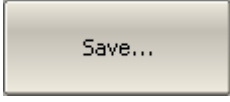
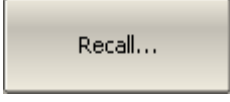
	To save the segment table, click <b>Save...</b> softkey.
	Then enter the file name in the appeared dialog.
	To recall the segment table, click <b>Recall...</b> softkey.
	Then select the file name in the appeared dialog.

The segment sweep graph has two methods of frequency axis representation. In the first, the axis displays the frequencies of the measurement points. In some cases it can be helpful to have the frequency axis displayed as sequential numbers. The second method displays the number of the measurement points.

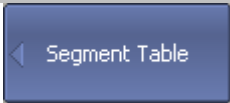
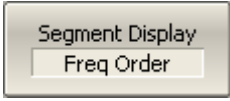
	To set the frequency axis display mode, click <b>Segment Display</b> softkey and select <b>Freq Order</b> or <b>Base Order</b> option.
	

#### 4.5.10 Measurement Delay

Measurement delay function allows for adding an additional time interval at each measurement point between the moment when the source output frequency becomes stable and the start of the measurement. This capability can be useful for measurements in narrowband circuits with transient periods longer than the measurement time per point.

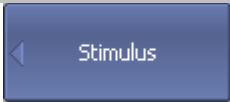
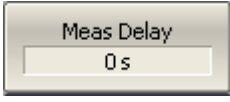
	To set the measurement delay time, use the following softkeys:
	<b>Stimulus &gt; Meas Delay</b>

## 4.6 Trigger Setting



The *trigger mode* determines the sweep actuation of the channel at a *trigger signal* detection. A channel can operate in one of the following three trigger modes:

- Continuous – a sweep actuation occurs every time a trigger signal is detected;
- Single – one sweep actuation occurs with trigger signal detection after the mode has been enabled; after the sweep is complete the channel modes changes to hold;
- Hold – sweep actuation is off in the channel, trigger signals do not affect the channel.

The trigger signal applies to the whole Analyzer and controls the triggering of all the channels in the following manner. If more than one channel window are open, the trigger activates successive measurements of all the channels which are not in hold mode. Before measurement of all channels is complete, all additional triggers are ignored. When measurement of all the channels is complete, if there is at least one channel in continuous trigger mode, the Analyzer will enter waiting for a trigger state.

The *trigger source* can be selected by the user from the following four available options:

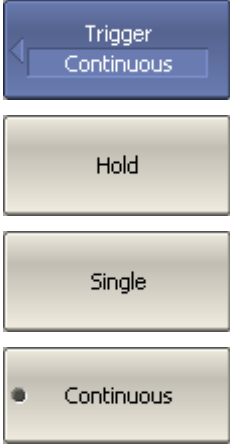
- Internal – the next trigger signal is generated by the Analyzer on completion of each sweep;
- External – the external trigger input is used as a trigger signal source;
- Manual – the trigger signal is generated by pressing the corresponding softkey.
- Bus – the trigger signal is generated by a command communicated from an external computer from a program controlling the Analyzer via COM/DCOM.

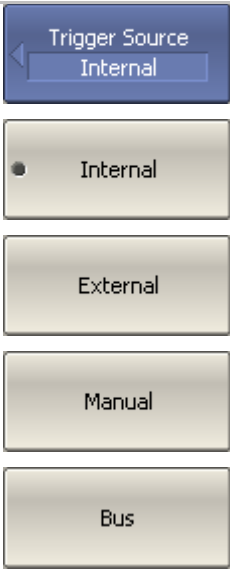
 <p>Trigger ← Continuous</p> <p>Hold</p> <p>Single</p> <p>● Continuous</p>	<p>To set the trigger mode, use the following softkeys:</p>
	<p><b>Stimulus &gt; Trigger</b></p>
	<p>Then select the required trigger mode:</p>
	<ul style="list-style-type: none"> <li>▪ Hold</li> <li>▪ Single</li> <li>▪ Continuous</li> </ul>
 <p>Hold All Channels</p> <p>Continuous All Channels</p>	<p><b>Hold All Channels</b> and <b>Continuous All Channels</b> softkeys turn all the channels to the respective mode.</p>
 <p>Restart</p> <p>Trigger</p>	<p><b>Restart</b> softkey aborts the sweep and returns the trigger system to the waiting for a trigger state.</p>
	<p><b>Trigger</b> softkey generates the trigger in manual trigger mode.</p>
 <p>Trigger Source ← Internal</p> <p>● Internal</p> <p>External</p> <p>Manual</p> <p>Bus</p>	<p>To set the trigger source, use the following softkeys:</p>
	<p><b>Stimulus &gt; Trigger &gt; Trigger Source</b></p>
	<p>Then select the required trigger source:</p>
	<ul style="list-style-type: none"> <li>▪ Internal</li> <li>▪ External</li> <li>▪ Manual</li> <li>▪ Bus</li> </ul>

#### 4.6.1 Point Feature for the External Trigger (Planar 804/1 and S models)

By default the trigger initiates a sweep measurement upon every trigger event for external, manual and bus sources. For the external trigger source, the point trigger feature instead initiates a point measurement upon each trigger event.

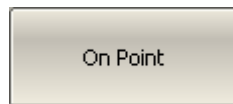
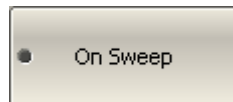

To enable the point trigger feature for external trigger source, use the following softkeys:

**Stimulus > Trigger > Ext Trig Event > On Point**

---

#### 4.6.2 External Trigger Polarity Setting (Planar 804/1 and S models)

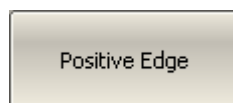
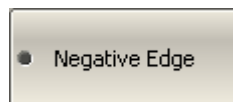

To select external trigger polarity, use the following softkeys:

**Stimulus > Trigger > Ext Trig Polarity > { Negative Edge | Positive Edge }**

---

## 4.7 Measurement Parameters Setting

### 4.7.1 S-Parameters

For high-frequency network analysis the following terms are used: incident, reflected, and transmitted waves (See Figure 19).

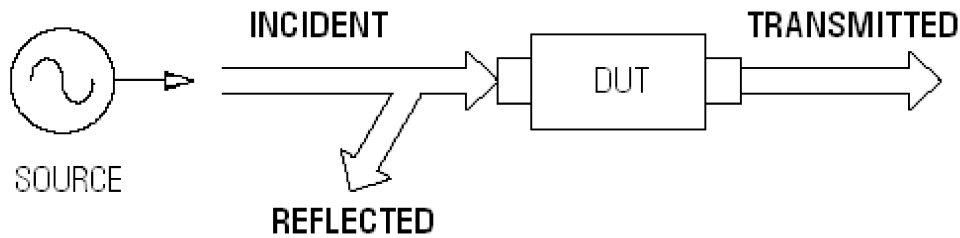

Figure 19

Measurement of the magnitude and phase of incident, reflected and transmitted signals allow for determining the S-parameters (scattered parameters) of the DUT. An S-parameter is a relation between the complex magnitudes of two waves:

$$S_{mn} = \frac{\text{transmitted wave at Port } m}{\text{incident wave at Port } n}$$

The Analyzer allows measurement of the full scattering matrix of a 2-port DUT:

$$\mathbf{S} = \begin{bmatrix} S_{11} & S_{12} \\ S_{21} & S_{22} \end{bmatrix}$$

To measure the full scattering matrix, you do not need to change the connection of the DUT to the Analyzer.

For the measurement of  $S_{11}$ ,  $S_{21}$  parameters, test Port 1 will operate as a signal source. The incident and reflected waves will be measured by Port 1. The transmitted wave will be measured by Port 2.

For the measurement of  $S_{12}$ ,  $S_{22}$  parameters, test Port 2 will operate as a signal source. The incident and reflected waves will be measured by Port 2. The transmitted wave will be measured by Port 1.



## 4.7.2 S-Parameter Setting

A measured parameter ( $S_{11}$ ,  $S_{21}$ ,  $S_{12}$ ,  $S_{22}$ ) is set for each trace. Before you select the measured parameter, first activate the trace.



To set the measured parameter, use the following softkey:

### Measurement

Then select the desired parameter by the corresponding softkey.

## 4.7.3 Absolute Measurements

Absolute measurements are measurements of the absolute power of a signal at a receiver input. Unlike relative measurements of S-parameters, which represent a relation between the signals at inputs of two receivers, absolute measurements determine the signal power at input of one receiver. A 2-port Analyzer has four independent receivers: **A**, **B**, **R1**, **R2** (See Figure 20).

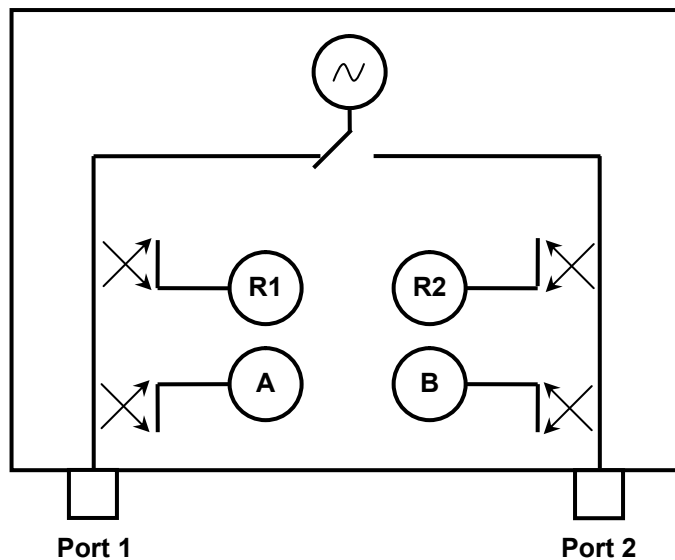

Figure 20 Analyzer block diagram

R1 and R2 are reference signal receivers; A and B are test signal receivers. The A and R1 receivers are located in Port 1; B and R2 receivers are located in Port 2. There are six types of absolute measurements depending on the port number (See Table 9):

Table 9 Absolute measurements

Symbols	Definition
<b>A(1)</b>	Test signal receiver A (Source Port 1)
<b>A(2)</b>	Test signal receiver A (Source Port 2)
<b>B(1)</b>	Test signal receiver B (Source Port 1)
<b>B(2)</b>	Test signal receiver B (Source Port 2)
<b>R1(1)</b>	Reference signal receiver R1 (Source Port 1)
<b>R2(2)</b>	Reference signal receiver R2 (Source Port 2)

#### 4.7.4 Absolute Measurement Setting

---

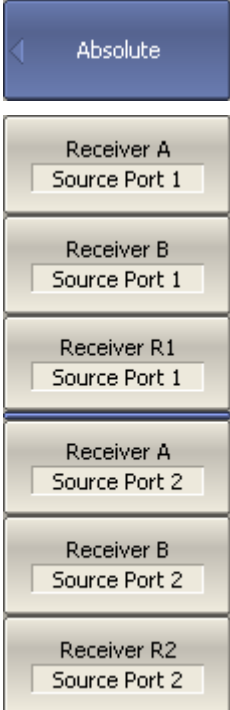
	<p>To select absolute measurement, click softkeys:  <b>Measurement &gt; Absolute &gt;</b></p> <p><b>Receiver A, Source Port 1  </b></p> <p><b>Receiver B, Source Port 1  </b></p> <p><b>Receiver R1, Source Port 1  </b></p> <p><b>Receiver A, Source Port 2  </b></p> <p><b>Receiver B, Source Port 2  </b></p> <p><b>Receiver R2, Source Port 2</b></p>
---	---

---

---

Note	In absolute measurement mode, <b>dBm</b> measurement units are used for logarithmic magnitude format, <b>W</b> measurement units are used for measurements in linear magnitude format. Other formats are not applicable to absolute measurements as power is measured in scalar values.
------	---

---

## 4.8 Format Setting

The Analyzer offers three S-parameter measurement display types:

- rectangular format;
- polar format;
- Smith chart format.

### 4.8.1 Rectangular Formats

In this format, stimulus values are plotted along X-axis and the measured data are plotted along Y-axis (See

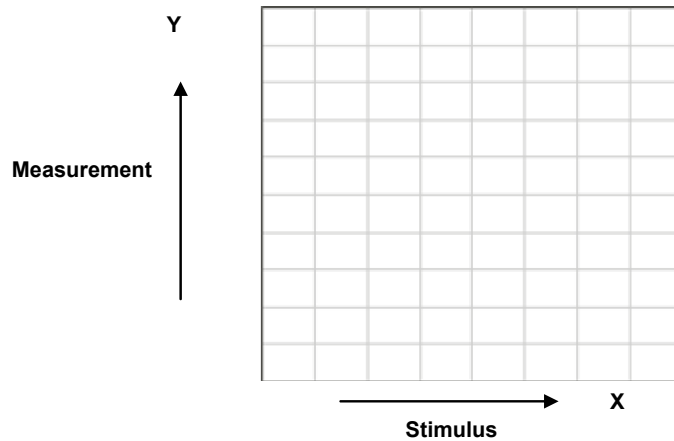

Figure 21).

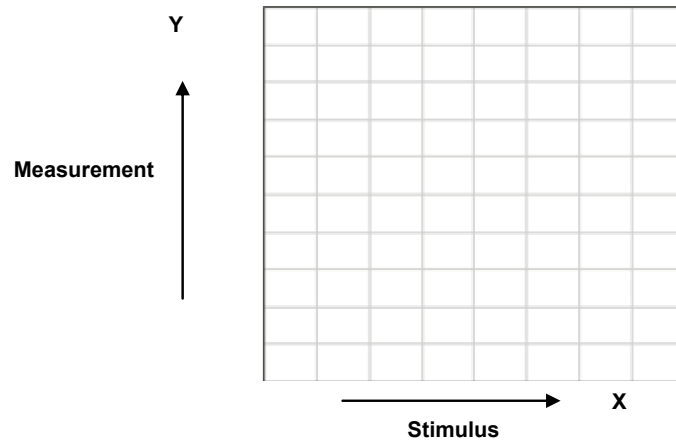

Figure 21 Rectangular format

To display complex-valued S-parameters along the scalar Y-axis, it must be transformed into a real number. Rectangular formats involve various types of transformation of an S-parameter  $S = a + j \cdot b$ , where:

- $a$  – real part of S-parameter complex value;
- $b$  – imaginary part of S-parameter complex value.

There are eight types of rectangular formats depending on the measured value plotted along Y-axis (See Table 10).

Table 10 Rectangular formats

Format Type Description	Label	Data Type (Y-axis)	Measurement Unit (Y-axis)
Logarithmic Magnitude	<b>Log Mag</b>	S-parameter logarithmic magnitude: $20 \cdot \log S $ , $ S  = \sqrt{a^2 + b^2}$	Decibel (dB)
Voltage Standing Wave Ratio	<b>SWR</b>	$\frac{1 +  S }{1 -  S }$	Dimensionless value
Phase	<b>Phase</b>	S-parameter phase from $-180^\circ$ to $+180^\circ$ : $\frac{180}{\pi} \cdot \text{arctg} \frac{a}{b}$	Degree ( $^\circ$ )
Expanded Phase	<b>Expand Phase</b>	S-parameter phase, measurement range expanded to from below $-180^\circ$ to over $+180^\circ$	Degree ( $^\circ$ )
Group Delay	<b>Group Delay</b>	Signal propagation delay within the DUT: $-\frac{d\varphi}{d\omega}$ , $\varphi = \text{arctg} \frac{a}{b}$ , $\omega = 2\pi \cdot f$	Second (sec.)
Linear Magnitude	<b>Lin Mag</b>	S-parameter linear magnitude: $\sqrt{a^2 + b^2}$	Dimensionless value
Real Part	<b>Real</b>	S-parameter real part: $a = \text{re}(S)$	Dimensionless value
Imaginary Part	<b>Imag</b>	S-parameter imaginary part: $b = \text{im}(S)$	Dimensionless value

## 4.8.2 Polar Format

Polar format represents the measurement results on the polar chart (See Figure 22). The distance of a measured point from the graph center corresponds to the magnitude of its value. The counterclockwise angle from the positive horizontal axis corresponds to the phase of the measured value.

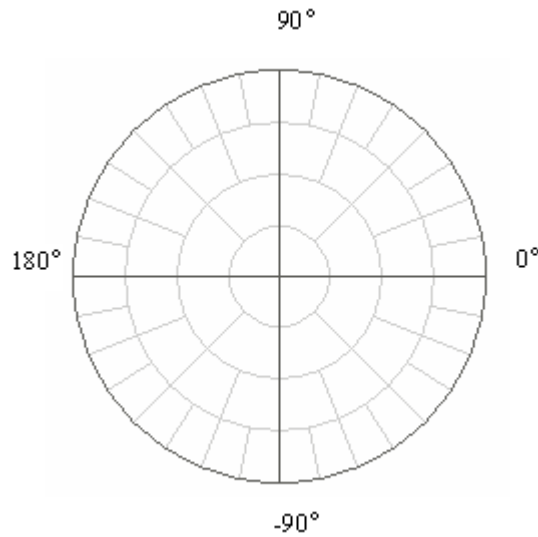

Figure 22 Polar format

The polar graph does not have a frequency axis, so frequency is indicated by markers. There are three types of polar formats corresponding to the data displayed by the marker; the traces remain the same for all the format types.

Table 11 Polar formats

Format Type Description	Label	Data Displayed by Marker	Measurement Unit (Y-axis)
Linear Magnitude and Phase	<b>Polar (Lin)</b>	S-parameter linear magnitude	Dimensionless value
		S-parameter phase	Degree (°)
Logarithmic Magnitude and Phase	<b>Polar (Log)</b>	S-parameter logarithmic magnitude	Decibel (dB)
		S-parameter phase	Degree (°)
Real and Imaginary Parts	<b>Polar (Re/Im)</b>	S-parameter real part	Dimensionless value
		S-parameter imaginary part	Dimensionless value

### 4.8.3 Smith Chart Format

Smith chart format is used for representation of impedance values for DUT reflection measurements. In this format, the trace has the same points as in polar format.

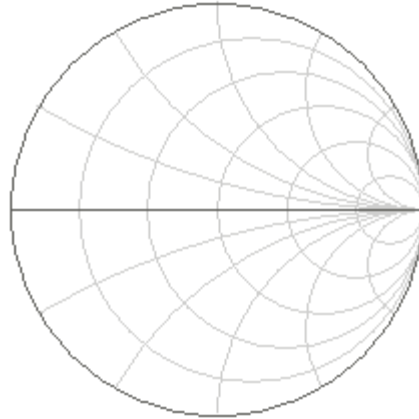

Figure 23 Smith chart format

The Smith chart does not have a frequency axis, so frequency is indicated by markers. There are five types of Smith chart formats corresponding to the data displayed by the marker; the traces remain the same for all the format types.

Table 12 Smith chart formats

Format Type Description	Label	Data Displayed by Marker	Measurement Unit (Y-axis)
Linear Magnitude and Phase	<b>Smith (Lin)</b>	S-parameter linear magnitude	Dimensionless value
		S-parameter phase	Degree (°)
Logarithmic Magnitude and Phase	<b>Smith (Log)</b>	S-parameter logarithmic magnitude	Decibel (dB)
		S-parameter phase	Degree (°)
Real and Imaginary Parts	<b>Smith (Re/Im)</b>	S-parameter real part	Dimensionless value
		S-parameter imaginary part	Dimensionless value

Table 12 Smith chart formats (continued)

Complex Impedance (at Input)	<b>Smith (R + jX)</b>	Resistance at input: $R = re(Z_{inp})$ , $Z_{inp} = Z_0 \frac{1+S}{1-S}$	Ohm ( $\Omega$ )
		Reactance at input: $X = im(Z_{inp})$	Ohm ( $\Omega$ )
		Equivalent capacitance or inductance: $C = -\frac{1}{\omega X}$ , $X < 0$ $L = \frac{X}{\omega}$ , $X > 0$	Farad (F) Henry (H)
Complex admittance (at Input)	<b>Smith (G + jB)</b>	Conductance at input: $G = re(Y_{inp})$ , $Y_{inp} = \frac{1}{Z_0} \cdot \frac{1-S}{1+S}$	Siemens (S)
		Susceptance at input: $B = im(Y_{inp})$	Siemens (S)
		Equivalent capacitance or inductance: $C = \frac{B}{\omega}$ , $B > 0$ $L = -\frac{1}{\omega B}$ , $B < 0$	Farad (F) Henry (H)

$Z_0$  – test port impedance.  $Z_0$  setting is described in section 5.2.12.



## 4.8.4 Data Format Setting

You can select the format for each trace of the channel individually. Before you set the format, first activate the trace.



To choose a rectangular format, use the following softkey:

### Format

Then select the desired format:

- **Logarithmic magnitude**
- **SWR**
- **Phase**
- **Expanded phase**
- **Group delay**
- **Linear magnitude**
- **Real part**
- **Imaginary part**



To choose a Smith chart format, use the following softkeys:

**Format > Smith**

Then select the desired format:

- **Logarithmic magnitude and phase**
- **Linear magnitude and phase**
- **Real and imaginary parts**
- **Complex impedance (at input)**
- **Complex admittance (at input)**

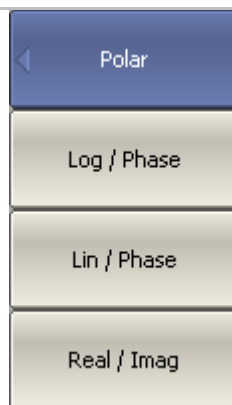

To choose a Polar format, use the following softkeys:

**Format > Polar**

Then select the desired format:

- **Logarithmic magnitude and phase**
  - **Linear magnitude and phase**
  - **Real and imaginary parts**
-

## 4.9 Scale Setting

### 4.9.1 Rectangular Scale

For rectangular format you can set the following parameters (See Figure 24):

- Scale division;
- Reference level value;
- Reference level position;
- Number of scale divisions.

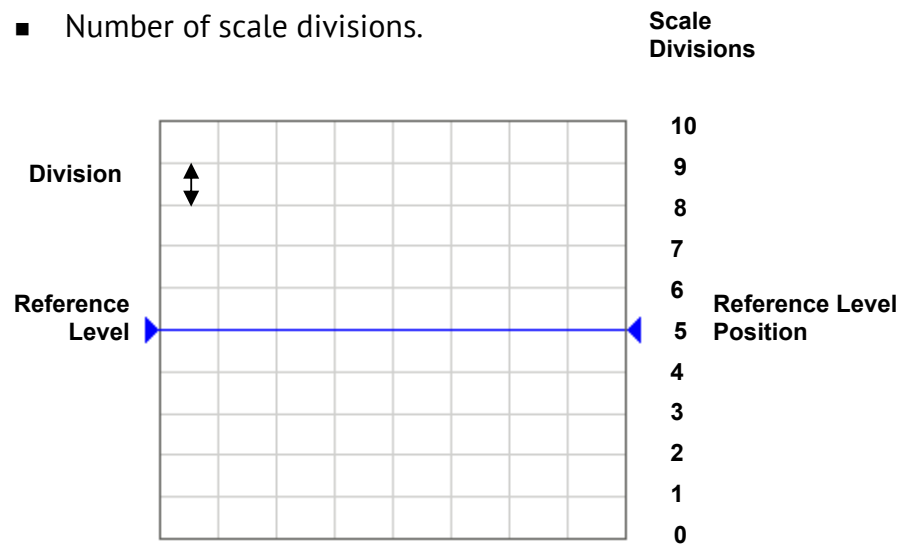
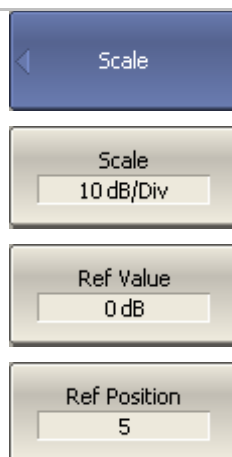

Figure 24 Rectangular scale

### 4.9.2 Rectangular Scale Setting

You can set the scale for each trace of a channel. Before you set the scale, first activate the trace.



To set the scale of a trace, use the following softkeys:

**Scale > Scale**

To set the reference level, use the following softkeys:

**Scale > Ref Value**

To set the position of the reference level, use the following softkeys:

**Scale > Ref Position**

To set the number of trace scale divisions, use the following softkeys:

**Scale > Divisions<sup>1</sup>**

Note

Quick trace scale setting by the mouse is described in section 4.3.

### 4.9.3 Circular Scale

For polar and Smith chart formats, you can set the outer circle value (See Figure 25).

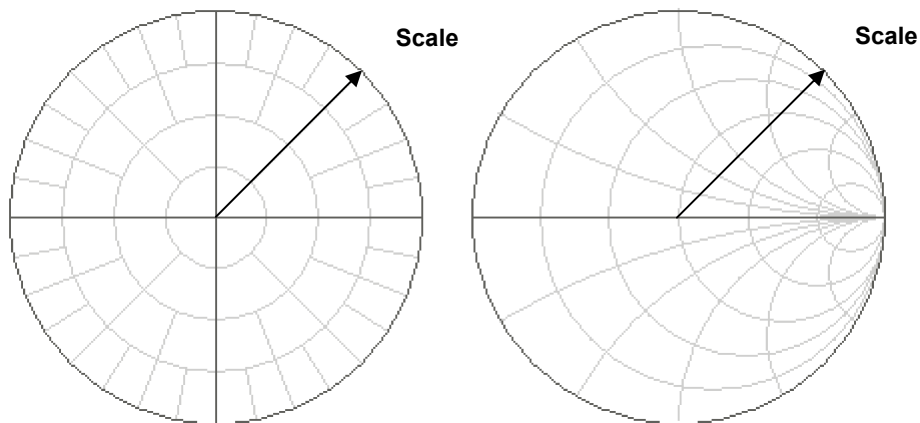
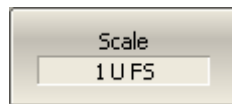

Figure 25 Circular scale

### 4.9.4 Circular Scale Setting



To set the scale of the circular graphs, use the following softkeys:

**Scale > Scale**

<sup>1</sup>

Number of the scale divisions affect all the graphs of the channel.

### 4.9.5 Automatic Scaling

The automatic scaling function automatically adjusts the trace scale so that the trace of the measured value fits into the graph entirely.

In rectangular format, two parameters are adjustable: scale division and reference level position. In circular format, the outer circle value is adjusted.

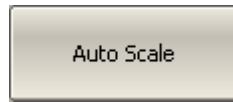
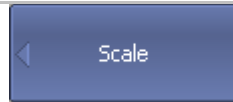

To execute the automatic scaling, use the following softkeys:

**Scale > Auto Scale**

### 4.9.6 Reference Level Automatic Selection

This function automatically selects the reference level in rectangular coordinates. After the function, the trace of the measured value shifts vertically so that the reference level crosses the graph in the middle. The scale division is unaffected.

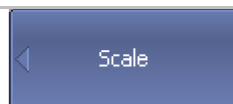

To execute automatic selection of the reference level, use the following softkeys:

**Scale > Auto Ref Value**

### 4.9.7 Electrical Delay Setting

The electrical delay function allows the user to define a compensation value for the electrical delay of a device. This value is useful during measurements of phase deviations from linear, for example. The electrical delay is set in seconds.

If the electrical delay setting is other than zero, the S-parameter value will vary in accordance with the following formula:

$$S = S_{meas} \cdot e^{j \cdot 2\pi \cdot f \cdot t}, \quad \text{where}$$

$f$  – frequency, Hz,

$t$  – electrical delay, sec.

The electrical delay is set for each trace independently. Before you set the electrical delay, first activate the trace.

---

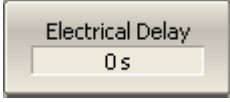
	To set the electrical delay, use the following softkeys:
	<b>Scale &gt; Electrical Delay</b>

---

#### 4.9.8 Phase Offset Setting

The phase offset function allows the user to define the constant phase offset of a trace. The value of the phase offset is set in degrees for each trace independently. Before you set the phase offset, first activate the trace.

---

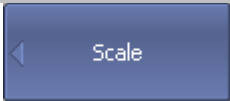
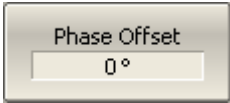
	To set the phase offset, use the following softkeys:
	<b>Scale &gt; Phase Offset</b>

---

## 4.10 Measurement Optimization

You can set IF bandwidth, averaging and smoothing parameters inside the **Average** softkey submenu.

### 4.10.1 IF Bandwidth Setting

The IF bandwidth setting allows the user to define the bandwidth of the test receiver. The IF bandwidth runs through the following sequence of numbers: 1, 1.5, 2, 3, 5, 7 within the range of the instrument capability.

Narrowing the IF bandwidth reduces self-noise and widens the dynamic range of the Analyzer, but the sweep time increases. Narrowing the IF bandwidth by 10 will nominally reduce receiver noise by 10 dB.

The IF bandwidth should be set for each channel independently. Before you set the IF bandwidth, first activate the channel.

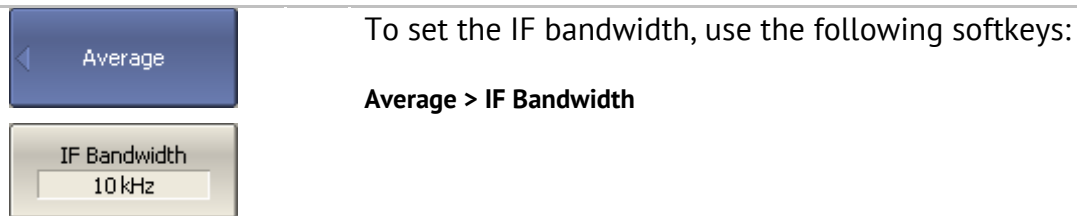

### 4.10.2 Averaging Setting

Averaging is performed at a measurement point over several previous sweeps. The benefits of the averaging function are similar to IF bandwidth narrowing. It allows for reduction of self-noise and widening the dynamic measurement range of the Analyzer.

Averaging of each measurement point is made across multiple sweeps in accordance with the following equation:

$$\begin{cases} M_i = S_i, & i = 0 \\ M_i = \left(1 - \frac{1}{n}\right) \cdot M_{i-1} + \frac{S_i}{n}, & i > 0, \quad n = \min(i+1, N) \end{cases}$$



$M_i$  – i-sweep averaging result;

$S_i$  – i-sweep measurement parameter (S-parameter) value;

$N$  – averaging factor is set by the user from 1 to 999; the higher the factor value the stronger the averaging effect.

When the averaging function is enabled, the current number of iterations and the averaging factor, e.g. «9/10», will appear in the channel status bar. The averaging process is considered stable when the two numbers are equal.

The averaging should be set for each channel individually. Before you set the averaging, first activate the channel.

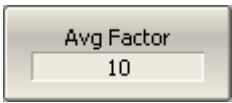
	<p>To toggle the averaging function on/off, use the following softkeys:</p>
	<p><b>Average &gt; Averaging</b></p>
	<p>To set the averaging factor, use the following softkeys:</p> <p><b>Averaging &gt; Avg Factor</b></p>

### 4.10.3 Smoothing Setting

Smoothing of the sweep result averages adjacent points of the trace as determined by the moving aperture. The aperture is set by the user as a percent of the total number of trace points.

Smoothing does not increase the dynamic range of the Analyzer, nor does it does affect the average level of the trace. Smoothing helps to reduce noise bursts. Smoothing is set for each trace independently. Before you configure smoothing, first activate the trace.

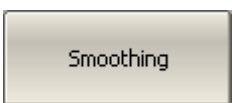
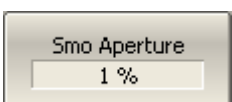
	<p>To toggle the smoothing function on/off, use the following softkeys:</p>
	<p><b>Averaging &gt; Smoothing</b></p>
	<p>To set the smoothing aperture, use the following softkeys:</p> <p><b>Averaging &gt; Smo Aperture</b></p>



## 4.11 Mixer Measurements

### 4.11.1 Mixer Measurement Methods

The Analyzer allows you to perform measurements of mixers and other frequency translating devices using scalar and vector methods.

The **scalar method** allows measurement of the scalar transmission S-parameters of frequency translating devices. Phase and group delay measurements are not accessible in this mode. The advantage of this method is the simplicity of measurement setup (no additional equipment necessary). See Figure 26.

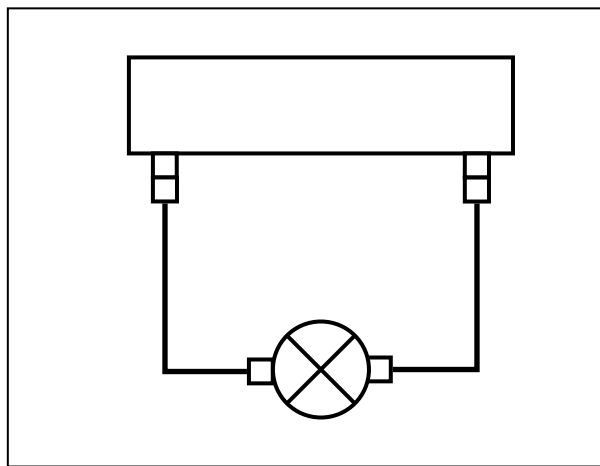

Figure 26 Scalar mixer measurement setup

The scalar measurement method is based on *frequency offset* mode. Frequency offset mode enables a frequency offset between the Analyzer test ports as described in detail in section 4.11.2. Frequency offset mode can be combined with various calibration methods.

When performing scalar measurements of a mixer, the most accurate method of calibration is *scalar mixer calibration* (See section 5.6).

An easier but less accurate method is using absolute measurements in combination with receiver calibration and power calibration (See sections 4.7.3, 5.5 and section 5.4). This method often results in transmission S-parameter ripples due to mixer input and output mismatch. This can be partially compensated by using matching attenuators of 3-10 dB at the mixer input and output.

The **vector mixer calibration method** allows for measurement of mixer transmission complex S-parameters including phase and group delay. The method requires additional equipment (See Figure 27): an external mixer with filter, which is called *calibration mixer*, and a LO common for both the calibration mixer and the mixer under test.

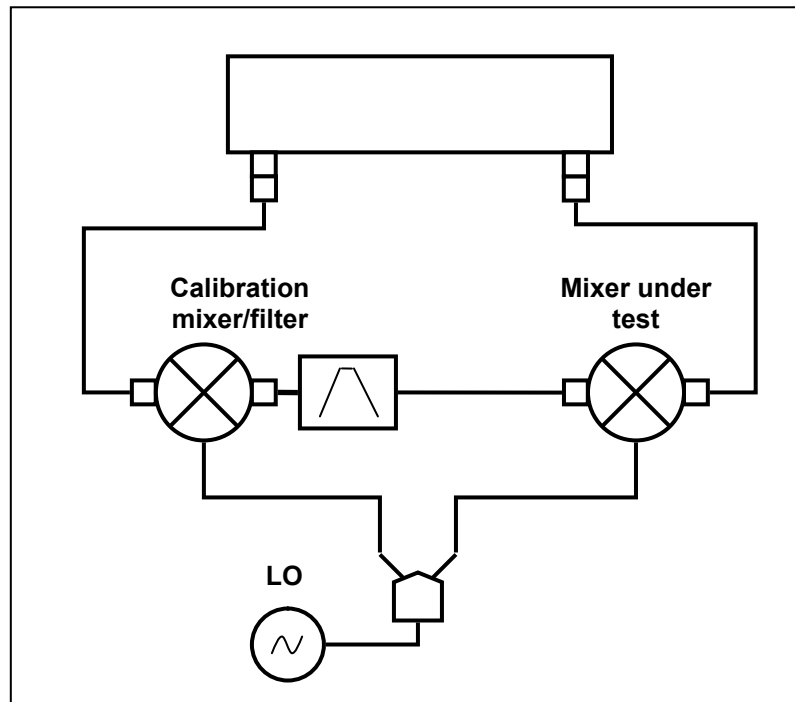

Figure 27 Vector mixer measurement setup

The vector mixer calibration method doesn't use frequency offset. The vector mixer calibration method ensures same frequency at the both test ports of the Analyzer, in normal operation mode. The vector mixer calibration procedure is described in the section 5.7.

#### 4.11.2 Frequency Offset Mode

The frequency offset mode enables you to measure transmission S-parameters of frequency translating devices. In this context, frequency translating devices include both frequency shifting devices such as mixers and converters, as well as devices dividing or multiplying frequency.

This measurement mode is based on a frequency offset between the receiver port frequency and source port frequency. The frequency offset is defined for each port using three coefficients: multiplier, divider, and offset. These coefficients allow for calculation of a port frequency relative to the *basic frequency range*.

$$F_{port} = \frac{M}{D} F_{base} + F_{ofs}$$

$M$  – multiplier,

$D$  – divider,

$F_{ofs}$  – offset,

$F_{base}$  – basic frequency.

In most cases it is sufficient to apply an offset to only one of the ports, leaving the other one at the basic frequency ( $M=1$ ,  $D=1$ ,  $Fofs=0$ ).

Below are some examples of offset coefficient calculation for different types of frequency conversion. Here the mixer input is connected to Port 1, and the mixer output is connected to Port 2. The second port of the Analyzer is running in frequency offset mode as follows:

---

1.  $IF = RF - LO$                       Port 2:  $M = 1$ ,  $D = 1$ ,  $Fofs = -LO$ .

---

2.  $IF = LO - RF$                       Port 2:  $M = -1$ ,  $D = 1$ ,  $Fofs = LO$ .

---

3.  $IF = RF + LO$                       Port 2:  $M = 1$ ,  $D = 1$ ,  $Fofs = LO$ .

---

In frequency offset mode, the bottom part of the channel window will indicate each port's frequency span (See Figure 28).

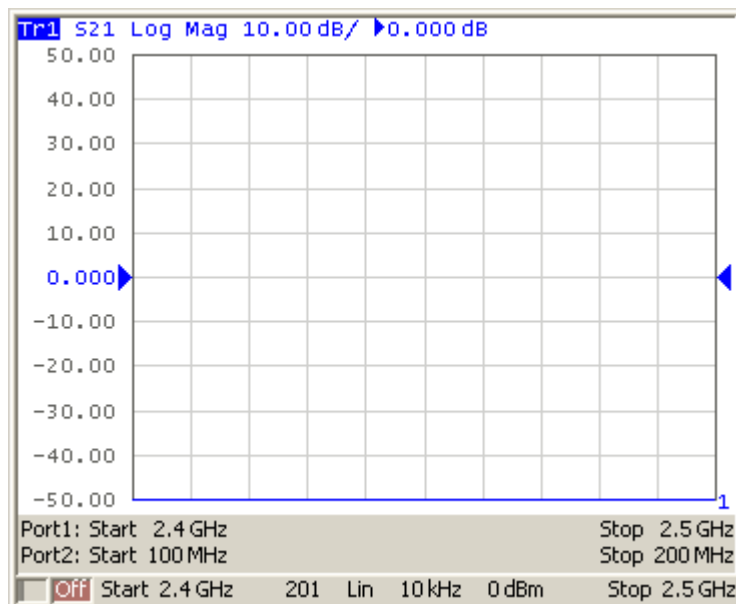
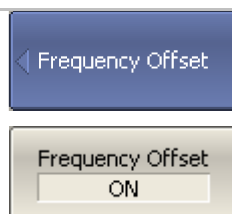

Figure 28 Channel window in frequency offset mode



To enable/disable frequency offset mode, use the following softkeys:

**Stimulus > Frequency Offset > Frequency Offset**



To enter offset coefficients for Port 1, use the following softkeys:

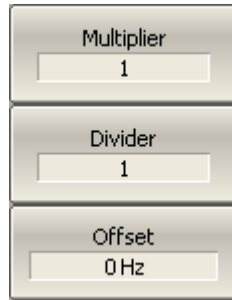

**Stimulus > Frequency Offset > Port 1 > { Multiplier | Divider | Offset }**



To enter offset coefficients for Port 2, use the following softkeys:



**Stimulus > Frequency Offset > Port 2 > { Multiplier | Divider | Offset }**

### 4.11.3 Setting Start and Stop Values in Offset Frequency Mode

User can set start and stop values in frequency offset mode for each port instead of using Multiplier, Divider and Offset values. Using Start/Stop values will set Multiplier and Offset, which can be determined from the specified frequency and the base frequency, while maintaining the preset Divider.

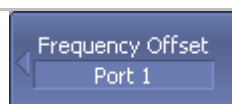

To set start and stop values in frequency offset mode for port n, use the following softkeys:



**Stimulus > Frequency Offset > Port n > { Start | Stop }**



To enable/disable frequency offset mode, use the following softkeys:

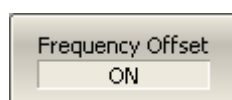

**Stimulus > Frequency Offset > Frequency Offset**

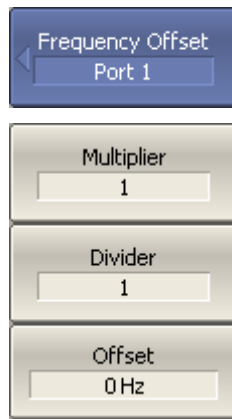

To enter offset coefficients for Port 1, use the following softkeys:

**Stimulus > Frequency Offset > Port 1 > { Multiplier | Divider | Offset }**

#### 4.11.4 Source/Receivers Frequency Offset Feature

Conventional frequency offset mode uses frequency offset between the ports, while the source and receivers of each port operate at a common frequency. Frequency offset between the ports allows for S-parameter measurement of frequency translating devices including vector reflection measurements and scalar transmission measurements.

The source/receivers frequency offset feature introduces a frequency offset between the source and receivers within a single port. Frequency offset between the source and receivers allows for absolute measurements only.



To enable source/receivers frequency offset feature, use the following softkeys:

**Stimulus > Frequency Offset > Offset Type > Source/Receivers**

#### 4.11.5 Automatic Adjustment of Offset Frequency

When you perform mixer measurements in frequency offset mode, you need to set the offset frequency equal to the LO frequency. The error of the offset frequency setting must be less than IF filter bandwidth, otherwise, the receiver will not receive the output signal from the mixer. In practice, there is always an LO frequency setting error (unknown to the user) when the tested mixer has an independent LO.

The Analyzer offers automatic adjustment of the offset frequency. This function enables you to accurately set the offset frequency equal to the frequency of the independent LO of the DUT.

Automatic adjustment of the offset frequency can be activated only for one port. The value of the offset frequency automatic adjustment will be indicated in the line of the respective port in the channel window (See Figure 29).

Automatic adjustment can be made within a  $\pm 500$  kHz range from the offset frequency set by the user. The function can be enabled/disabled by the user. Adjustment can be performed upon key pressing, or periodically at a set time interval.

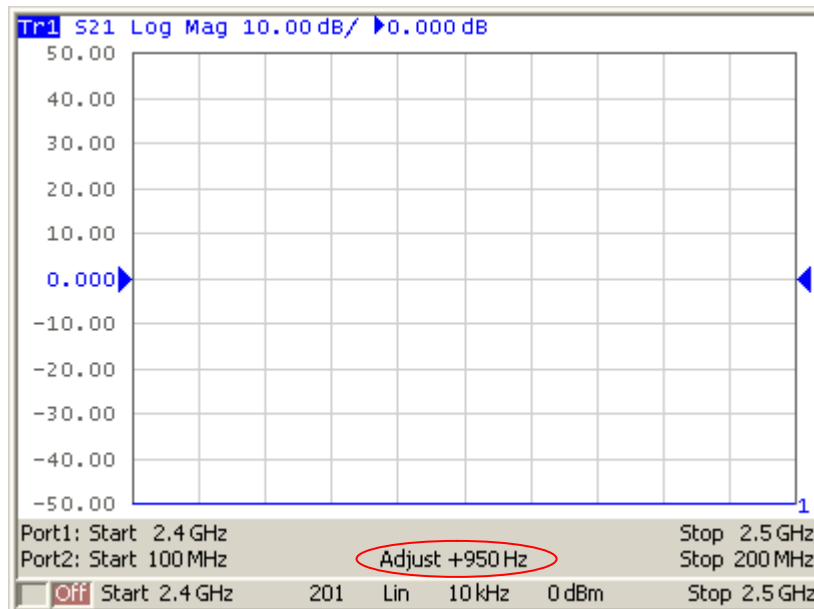



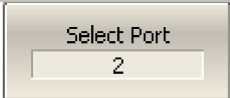

Figure 29 Channel window in frequency offset mode with enabled automatic adjustment function of the offset frequency

The typical error of automatic adjustment of the offset frequency depends on the current IF filter bandwidth (See Table 13).

Table 13 Typical error of offset frequency automatic adjustment

IF Filter Bandwidth	Typical Error of Offset Frequency Automatic Adjustment
10 kHz	500 Hz
3 kHz	50 Hz
1 kHz	15 Hz
300 Hz	5 Hz
100 Hz	2 Hz

### 4.11.5.1 Setting of Offset Frequency Automatic Adjustment

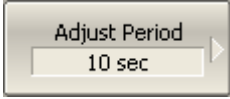
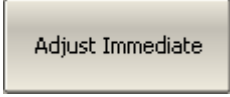
	<p>To enable/disable automatic adjustment function of the offset frequency, use the following softkeys:</p>
	<p><b>Stimulus &gt; Frequency Offset &gt; Offset Adjust &gt; Offset Adjust</b></p>
	<p>To select the port, use the following softkeys:</p>
<p><b>Stimulus &gt; Frequency Offset &gt; Offset Adjust &gt; Select Port</b></p>	<p>Note: normally, it is the port with enabled frequency offset.</p>
	<p>To enter the adjustment value use the following softkeys:</p>
<p><b>Stimulus &gt; Frequency Offset &gt; Offset Adjust &gt; Adjust Value</b></p>	<p>Note: or click <b>Adjust Immediate</b>, as described below.</p>
	<p>To enable/disable continuous adjustment, use the following softkeys:</p>
	<p><b>Stimulus &gt; Frequency Offset &gt; Offset Adjust &gt; Continuous Adjust</b></p>
<p>To enter the time interval for continuous adjustment, use the following softkeys:</p>	<p><b>Stimulus &gt; Frequency Offset &gt; Offset Adjust &gt; Adjust Period</b></p>
	<p>To initiate a single adjustment, use the following softkeys:</p>
<p><b>Stimulus &gt; Frequency Offset &gt; Offset Adjust &gt; Adjust Immediate</b></p>	

## 5 CALIBRATION AND CALIBRATION KIT

### 5.1 General Information

#### 5.1.1 Measurement Errors

S-parameter measurements are influenced by various measurement errors, which can be broken down into two categories:

- systematic errors, and
- random errors.

Random errors comprise such errors as noise fluctuations and thermal drift in electronic components, changes in the mechanical dimensions of cables and connectors subject to temperature drift, repeatability of connections and cable bends. Random errors are unpredictable and hence cannot be estimated and eliminated in calibration. Random errors can be reduced by correct setting of the source power, IF bandwidth narrowing, sweep averaging, maintaining a constant environment temperature, observance of the Analyzer warm-up time, careful connector handling, and avoidance of cable bending after calibration.

Random errors and related methods of correction are not mentioned further in this section.

Systematic errors are errors caused by imperfections in the components of the measurement system. Such errors occur repeatedly and their characteristics do not change with time. Systematic errors can be determined and then reduced by performing mathematical correction of the measurement results.

The process of measurement of precision devices with predefined parameters with the purpose of determining systematic errors is called **calibration**, and such precision devices are called **calibration standards**. The most commonly used calibration standards are SHORT, OPEN, and LOAD.

The process of mathematical compensation (numerical reduction) for measurement systematic errors is called **error correction**.



## 5.1.2 Systematic Errors

The systematic measurement errors of vector network analyzers are subdivided into the following categories according to their source:

- Directivity;
- Source match;
- Load match;
- Isolation;
- Reflection/transmission tracking.

The measurement results before error correction are called **uncorrected**.

The residual values of the measurement results after error correction are called **effective**.

### 5.1.2.1 Directivity Error

A directivity error (**Ed**) is caused by incomplete separation of the incident signal from the reflected signal by the directional coupler in the source port. In this case part of the incident signal energy enters the receiver of the reflected signal. Directivity errors do not depend on the characteristics of the DUT and usually have a greater effect in reflection measurements.

### 5.1.2.2 Source Match Error

A source match error (**Es**) is caused by mismatch between the source port and the input of the DUT. In this case part of the signal reflected by the DUT reflects at the source port and re-enters the input of the DUT. The error occurs effects both reflection measurement and transmission measurement. Source match errors depend on the difference between the input impedance of the DUT and test port impedance when it functions as a signal source.

Source match errors have strong effect in measurements of a DUT with poor input matching.

### 5.1.2.3 Load Match Error

A load match error (**El**) is caused by mismatch between the receiver port and the output of the DUT. In this case part of the signal transmitted through the DUT reflects at the receiver port and returns to the output of the DUT. The error occurs in transmission measurements and in reflection measurements (for a 2-port DUT).

Load match errors depend on the difference between output impedance of the DUT and test port impedance when used as a signal receiver.

In transmission measurements, the load match error has considerable influence if the output of the DUT is poorly matched. In reflection measurements, the load match error has considerable influence in case of poor output match and low attenuation between the output and input of the DUT.

#### 5.1.2.4 Isolation Error

Isolation error (**Ex**) is caused by a leakage of the signal from the source port to the receiver port bypassing the DUT.

The Analyzer has very good isolation, which allows us to ignore this error for most measurements. Isolation error measurement is an optional step in all types of calibration.

#### 5.1.2.5 Reflection Tracking Error

A reflection tracking error (**Er**) is caused by differences in frequency response between the test receiver and the reference receiver of the source port in reflection measurement.

#### 5.1.2.6 Transmission Tracking Error

A transmission tracking error (**Et**) is caused by differences in frequency response between the test receiver of the receiver port and the reference receiver of the source port in transmission measurement.

### 5.1.3 Error Modeling

Error modeling and the methodology of signal flow graphs are applied to vector network analyzers for analysis of systematic errors.

#### 5.1.3.1 One-Port Error Model

In reflection measurement, only one port of the Analyzer is used. The signal flow graph of errors for Port 1 is represented in Figure 30. For Port 2 the signal flow graph of the errors will be similar.

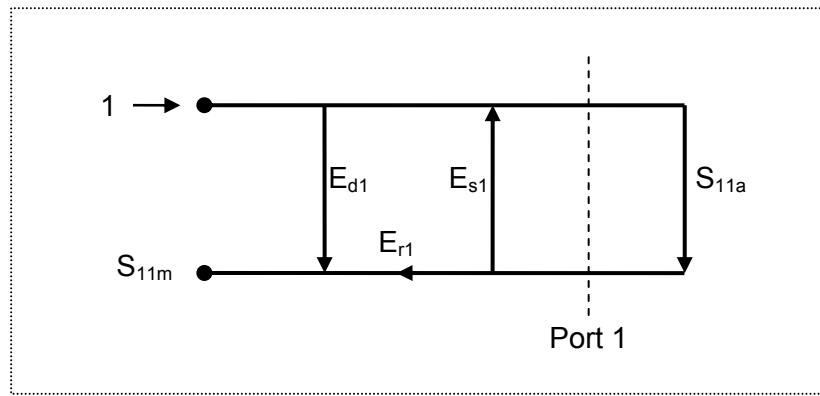

Figure 30 One-port error model

Where:

- $S_{11a}$  – reflection coefficient true value;
- $S_{11m}$  – reflection coefficient measured value.

The measurement result at Port 1 is affected by the following three systematic error terms:

- $E_{d1}$  – directivity;
- $E_{s1}$  – source match;
- $E_{r1}$  – reflection tracking.

For normalization the stimulus value is taken equal to 1. All the values used in the model are complex.

After determining all the three error terms  $E_{d1}$ ,  $E_{s1}$ ,  $E_{r1}$  for each measurement frequency by means of a **full 1-port calibration**, it is possible to calculate (mathematically subtract the errors from the measured value  $S_{11m}$ ) the true value of the reflection coefficient  $S_{11a}$ .

There are simplified methods, which eliminate the effects of only one or two of the three systematic errors.

### 5.1.3.2 Two-Port Error Model

For two-port measurements, two signal flow graphs are considered. One of the graphs describes the case where Port 1 is the stimulus source, the other graph describes the case where Port 2 is the stimulus source.

The signal flow graphs of errors effect in a two-port system are represented in Figure 31:

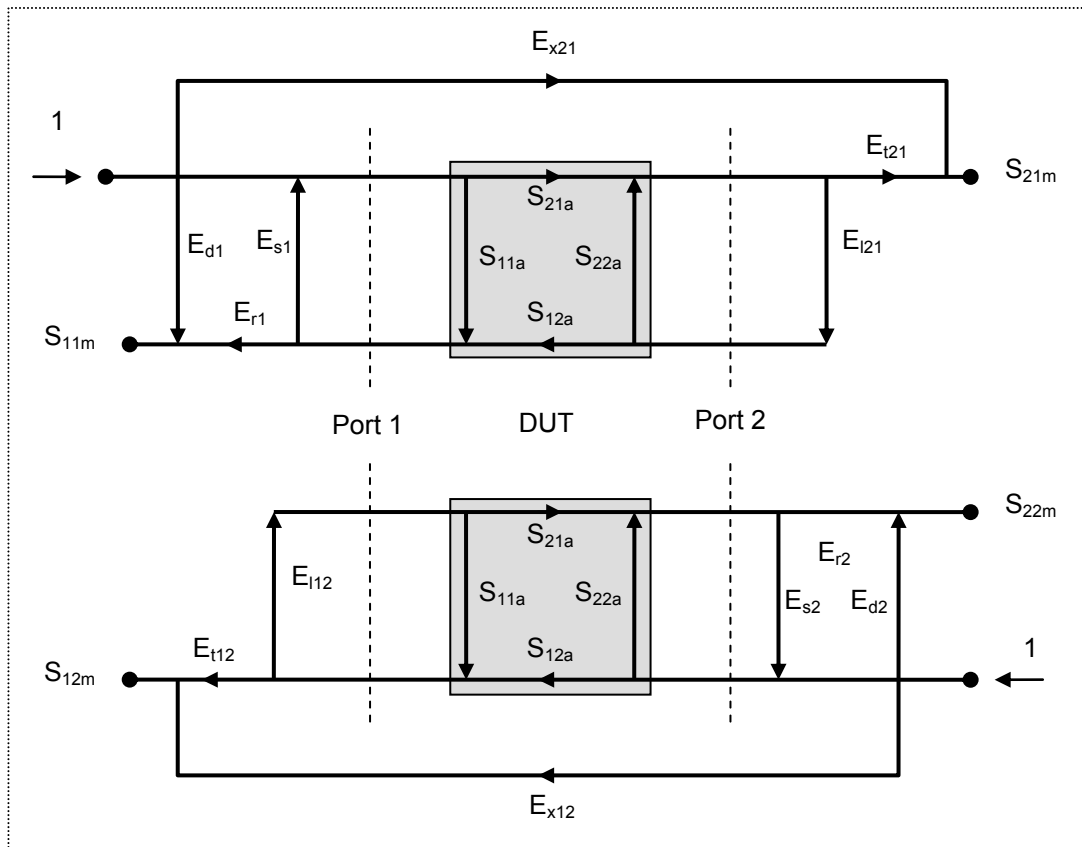

Figure 31 Two-port error model

Where:

- $S_{11a}, S_{21a}, S_{12a}, S_{22a}$  – true values of the DUT parameters;
- $S_{11m}, S_{21m}, S_{12m}, S_{22m}$  – measured DUT parameter values.

For normalization the stimulus value is taken equal to 1. All the values used in the model are complex. The measurement result in a two-port system is affected by twelve systematic error terms.

Table 14 Systematic error terms

Description	Stimulus Source	
	Port 1	Port 2
Directivity	$E_{d1}$	$E_{d2}$
Source match	$E_{s1}$	$E_{s2}$
Reflection tracking	$E_{r1}$	$E_{r2}$
Transmission tracking	$E_{t1}$	$E_{t2}$
Load match	$E_{l1}$	$E_{l2}$
Isolation	$E_{x1}$	$E_{x2}$

After determination of all twelve error terms for each measurement frequency by means of a **2-port calibration**, it is possible to calculate the true value of the S-parameters:  $S_{11a}$ ,  $S_{21a}$ ,  $S_{12a}$ ,  $S_{22a}$ .

There are simplified methods, which eliminate the effect of only one or several of the twelve systematic error terms.

Note	If you use a 2-port calibration, to determine any of S-parameters you need to know all four measurements $S_{11m}$ , $S_{21m}$ , $S_{12m}$ , $S_{22m}$ . That is why updating one or all of the S-parameters necessitates two sweeps: first with Port 1 as a signal source, and then with Port 2 as a signal source.
------	--

#### 5.1.4 Analyzer Test Port Definition

The test ports of the Analyzer are defined by means of calibration. The test port is a connector accepting a calibration standard in the process of calibration.

A type-N connector on the front panel of the Analyzer will be the test port if calibration standards are connected directly to it.

Sometimes it is necessary to connect coaxial cables and/or adapters to the connector(s) on the front panel to interface with a DUT of a different connector type. In such cases, calibration standards are connected to the connector of the cable or adapter.

Figure 32 represents two cases of test port definition for 2-port measurements. The use of cables and/or adapters does not affect the measurement results if they are integrated into the process of calibration.

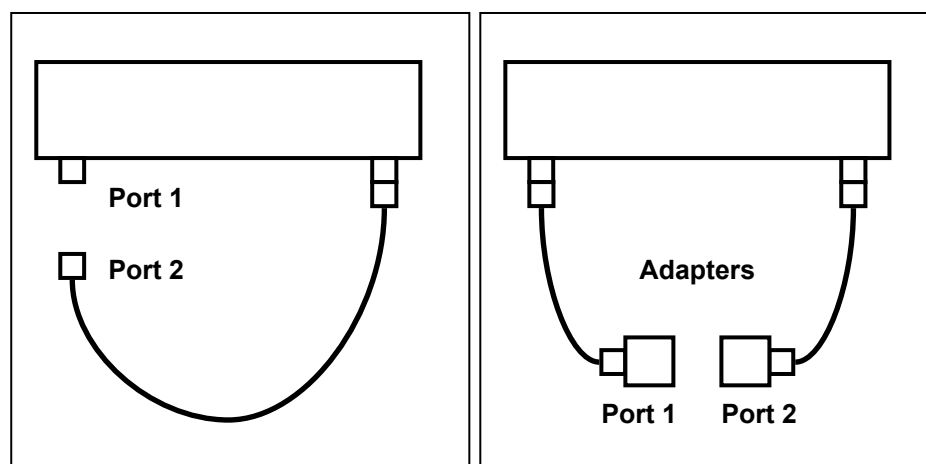

Figure 32 Test port defining

In some cases, the term *calibration plane* is used. Calibration plane is an imaginary plane located at the ends of the connectors, which accept calibration standards during calibration.

### 5.1.5 Calibration Steps

The process of calibration comprises the following steps:

- Selection of a calibration kit matching the connector type of the test port. The calibration kit includes such standards as SHORT, OPEN, and LOAD with matched impedance. Magnitude and phase responses i.e. S-parameters of the standards are well known. The characteristics of the standards are represented in the form of an **equivalent circuit model**, as described below;
- Selection of a calibration method (see section 5.1.6) is based on the required accuracy of measurements. The calibration method determines what error terms of the model (or all of them) will be compensated;
- Measurement of the standards within a specified frequency range. The number of the measurements depends on the type of calibration;
- The Analyzer compares the measured parameters of the standards against their predefined values. The difference is used for calculation of the calibration coefficients (systematic errors);
- The table of calibration coefficients is saved into the memory of the Analyzer and used for error correction of the measured results of any DUT.

Calibration is always made for a specific channel, as it depends on the channel stimulus settings, particularly on the frequency span. This means that a table of calibration coefficients is being stored each for an individual channel.

### 5.1.6 Calibration Methods

The Analyzer supports several methods of one-port and two-port calibration. The calibration methods vary by quantity and type of the standards being used, by type of error correction, and accuracy. The table below presents an overview of calibration methods.

Table 15 Calibration methods

Calibration Method	Parameters	Standards	Errors	Accuracy
Reflection Normalization	$S_{11}$ or $S_{22}$	<ul style="list-style-type: none"> <li>▪ SHORT or OPEN</li> <li>▪ LOAD <sup>1</sup></li> </ul>	$E_{r1}, E_{d1}$ <sup>1</sup> or $E_{r2}, E_{d2}$ <sup>1</sup>	High
Transmission Normalization	$S_{21}$ or $S_{12}$	<ul style="list-style-type: none"> <li>▪ THRU</li> <li>▪ 2 LOADS <sup>2</sup></li> </ul>	$E_{t1}, E_{x1}$ <sup>2</sup> or $E_{t2}, E_{x2}$ <sup>2</sup>	Low
Full One-Port Calibration	$S_{11}$ or $S_{22}$	<ul style="list-style-type: none"> <li>▪ SHORT</li> <li>▪ OPEN</li> <li>▪ LOAD</li> </ul>	$E_{r1}, E_{d1}, E_{s1}$ or $E_{r2}, E_{d2}, E_{s1}$	High
One-Path Two-Port Calibration	$S_{11}, S_{21}$ or $S_{12}, S_{22}$	<ul style="list-style-type: none"> <li>▪ SHORT</li> <li>▪ OPEN</li> <li>▪ LOAD</li> <li>▪ THRU</li> <li>▪ 2 LOADS <sup>2</sup></li> </ul>	$E_{r1}, E_{d1}, E_{s1}, E_{t1}, E_{x1}$ <sup>2</sup> or $E_{r1}, E_{d1}, E_{s1}, E_{t1}, E_{x1}$ <sup>2</sup>	Medium
Full Two-Port Calibration	$S_{11}, S_{21}$ $S_{12}, S_{22}$	<ul style="list-style-type: none"> <li>▪ SHORT</li> <li>▪ OPEN</li> <li>▪ LOAD</li> <li>▪ THRU</li> <li>▪ 2 LOADS <sup>2</sup></li> </ul>	$E_{r1}, E_{d1}, E_{s1}, E_{t1}, E_{l1}, E_{x1}$ <sup>2</sup> $E_{r2}, E_{d2}, E_{s2}, E_{t2}, E_{l2}, E_{x2}$ <sup>2</sup>	High
TRL Calibration (Planar 804/1 and S models)	$S_{11}, S_{21}$ $S_{12}, S_{22}$	<ul style="list-style-type: none"> <li>▪ THRU or LINE</li> <li>▪ REFLECT</li> <li>▪ LINE or 2 LOADS</li> </ul>	$E_{r1}, E_{d1}, E_{s1}, E_{t1}, E_{l1}$ $E_{r2}, E_{d2}, E_{s2}, E_{t2}, E_{l2}$	Very High

<sup>1</sup> If optional directivity calibration is performed.

<sup>2</sup> If optional isolation calibration is performed.

### 5.1.6.1 Normalization

Normalization is the simplest method of calibration as it involves measurement of only one calibration standard for each S-parameter.

- 1-port (reflection) S-parameters ( $S_{11}$ ,  $S_{22}$ ) are calibrated by means of a SHORT or an OPEN standard, estimating the reflection tracking error term **Er**.
- 2-port (transmission) S-parameters ( $S_{21}$ ,  $S_{12}$ ) are calibrated by means of a THRU standard, estimating the transmission tracking error term **Et**.

This method is called normalization because the measured S-parameter at each frequency point is divided (normalized) by the corresponding S-parameter of the calibration standard.

Normalization eliminates frequency-dependent attenuation and phase offset in the measurement circuit, but does not compensate for errors of directivity, mismatch or isolation. This constrains the accuracy of the method.

---

Note	Normalization can also be referred to as <b>response open</b> , <b>response short</b> or <b>response thru</b> calibration depending on the standard being used: an OPEN, SHORT or THRU respectively.
------	--

---

### 5.1.6.2 Directivity Calibration (Optional)

The Analyzer offers an optional directivity (**Ed**) calibration feature, which can be used in combination with reflection normalization by means of measurement of a LOAD standard. Auxiliary directivity correction increases the accuracy of normalization.

### 5.1.6.3 Isolation Calibration (Optional)

The Analyzer offers optional isolation (**Ex**) calibration to be combined with the following three methods of calibration:

- transmission normalization,
- one-path two-port calibration,
- full two-port calibration.



This calibration is performed by isolation measurement using LOAD standards connected to both test ports of the Analyzer. Isolation calibration can be omitted in most tests, as the signal leakage between the test ports of the Analyzer is negligible.

---

Note	For isolation calibration, it is recommended to set a narrow IF bandwidth and firmly fix the cables.
------	--

---

#### 5.1.6.4 Full One-Port Calibration

Full one-port calibration involves connection of the following three standards to one test port:

- SHORT,
- OPEN,
- LOAD.

Measurement of the three standards allows for acquisition of all the three error terms (**Ed, Es, and Er**) of a one-port model. Full 1-port calibration is a highly accurate method for 1-port reflection measurements.

#### 5.1.6.5 One-Path Two-Port Calibration

A one-path two-port calibration combines full one-port calibration with transmission normalization. This method allows for a more accurate estimation of transmission tracking error (**Et**) than using transmission normalization.

One-path two-port calibration involves connection of the three standards to the source port of the Analyzer (as for one-port calibration) and a THRU standard connection between the calibrated source port and the other receiver port.

One-path two-port calibration allows for correction of **Ed, Es,** and **Er** error terms of the source port and a transmission tracking error term (**Et**). This method does not derive source match error term (**El**) of a 2-port error model.

One-path two-port calibration is used for measurements of the parameters of a DUT in one direction, e.g.  $S_{11}$  and  $S_{21}$ .

### 5.1.6.6 Full Two-Port Calibration

A full two-port calibration involves seven connections of standards. This calibration combines two full 1-port calibrations for each port, and one THRU connection, which provides transmission measurements with each test port as a source. If optional isolation calibration is required, connect LOAD standards to the both test ports of the Analyzer and perform isolation measurements for each source port.

Full 2-port calibration allows for correction of all the twelve error terms of a 2-port error model:  $E_{d1}$ ,  $E_{d2}$ ,  $E_{s1}$ ,  $E_{s2}$ ,  $E_{r1}$ ,  $E_{r2}$ ,  $E_{t1}$ ,  $E_{t2}$ ,  $E_{l1}$ ,  $E_{l2}$ ,  $E_{x1}$ ,  $E_{x2}$  (correction of  $E_{x1}$ ,  $E_{x2}$  can be omitted).

Full 2-port calibration is a highly accurate method of calibration for 2-port DUT measurements.

### 5.1.6.7 Sliding Load Calibration

In full one-port and full two-port calibrations it is possible to employ a SLIDING LOAD calibration standard instead of a fixed one. The use of the SLIDING LOAD standard allows for significant increase in calibration accuracy at high frequencies compared to the FIXED LOAD standard.

The sliding load calibration involves a series of measurements in different positions of the sliding element to compensate for reflection from the dissipation component.

To activate the sliding load calibration algorithm, the selected calibration kit should contain a calibration standard of sliding load type, and it should be assigned to the "load" *class* of the corresponding port. Calibration standard editing and class assignment are further described in detail in section 5.3.

The sliding load calibration is not suitable for low frequencies. To eliminate this limitation, use a FIXED LOAD standard in the lower part of the frequency range. For combined calibration with SLIDING and FIXED LOADS, use the procedure of standard *subclasses* assigning. This procedure is described in detail in section 5.3.4.

### 5.1.6.8 Unknown Thru Calibration (Planar 804/1 and S models)

UNKNOWN THRU calibration standard is used only in full two-port calibration, which is also known as SOLT (Short, Open, Load, Thru) calibration.

This calibration method involves connecting the test ports to each other, referred to as the THRU. If the connectors' gender or type prevent direct connection, a DEFINED THRU is used. But it is not always possible to know the exact parameters of the THRU, in this case UNKNOWN THRU calibration can be used.

An arbitrary two-port device with unknown parameters can be used as an UNKNOWN THRU. An UNKNOWN THRU should satisfy only two requirements.

The first requirement applies to the transmission coefficient of the THRU. It should satisfy the reciprocity condition ( $S_{21} = S_{12}$ ), which holds for almost any passive network. Furthermore, it is not recommended to use a THRU with the loss higher than 20 dB as it can reduce the calibration accuracy.

The second requirement is knowledge of the approximate electrical length of the UNKNOWN THRU within an accuracy of 1/4 of the wavelength at the maximum calibration frequency. This requirement, however, can be omitted if the following frequency step size condition is met:

$$\Delta F < \frac{1}{4 \cdot \tau_0}, \quad \text{where } \tau_0 \text{ – delay of a two-port device.}$$

In this case the Analyzer program will automatically determine the electrical length (delay) of the two-port device.

In other words, you can perform calibration without specifying the delay of the UNKNOWN THRU if the frequency increment is sufficiently small. For example, with an UNKNOWN THRU having  $l_0 \approx 100 \text{ mm}$  and delay coefficient  $1/\sqrt{\epsilon} \approx 0.7$ , the delay will be  $\tau_0 \approx 477 \text{ ps}$ . In this case the maximum frequency increment for automatic estimation of the UNKNOWN THRU delay should be set to  $\Delta F < 524 \text{ MHz}$ ; equivalently the number of points within a sweep span of 8 GHz should be no less than 16. To ensure reliable operation, set the frequency increment, or equivalently the number of points, to provide at least double margin.

To use unknown thru calibration as part of full two-port calibration, the calibration kit definition should include an UNKNOWN THRU standard, assigned to the THRU class, for the two ports. The procedure of calibration standards editing and their assignment to classes is further described in detail in section 5.3.

An UNKNOWN THRU is defined automatically if you set the delay to zero in the calibration kit editing menu. Otherwise the user-defined delay value will be used. This value should be set to within 1/4 wavelength of the true delay at the maximum calibration frequency.

### 5.1.6.9 TRL Calibration (Planar 804/1 and S models only)

TRL (Thru-Reflect-Line) calibration is the most accurate calibration method described herein, as it uses airlines as calibration standards. The TRL calibration requires the use of the following calibration standards:

- THRU or REFERENCE LINE,
- REFLECT (SHORT or OPEN),
- Second LINE or two MATCHes.

TRL is a general name for a calibration family, which comprises such calibrations as LRL, TRM, or LRM named depending on the calibration standards used.

If a zero-length THRU is used as the first standard, the method is called TRL calibration. If a non-zero length LINE is used as the first standard, the calibration method is called LRL (Line-Reflect-Line). To denote the first standard of the TRL and LRL calibration, assign *TRL-Thru* class, which includes THRU and LINEs. A LINE of *TRL-Thru* class is also called *Reference Line*.

An OPEN or SHORT is usually used as a second standard in TRL calibration. To denote the second standard of the TRL calibration, assign *TRL-Reflect* class.

A second LINE is used as the third standard in TRL calibration. At low frequencies, at which MATCHes work well, two MATCHes can be used, as they are an equivalent of a matched line of infinite length. In the latter case, the calibration method is called TRM (Thru-Reflect-Match) or LRM (Line-Reflect-Match) respectively. To denote the third standard of the TRL calibration, assign *TRL-line/match* class, which includes LINEs and MATCHes.

#### Frequency Range

TRL and LRL calibrations have a limited bandwidth, suitable for lower to upper frequency ratios up to 1:8. The band limits depend on the LINE length in TRL calibration or on the difference between the lengths of the two LINEs in LRL calibration.

In theory TRM and LRM calibrations do not have limitations in frequency, however their practical use at higher frequencies is limited by the quality of the MATCHes. It is recommended to use the TRM and LRM calibrations up to 1 GHz.

## Impedance of LINES and MATCHes

All the LINES and MATCHes used for TRL calibration must have Z0 impedance values as precise as possible. TRL calibration transfers the impedance of standards into the calibrated system. Precise airlines with an accurate Z0 impedance of 50 Ω are used as LINES in coaxial paths.

### REFERENCE LINE

A zero-length THRU is used as the first standard in TRL calibration. In LRL calibration a LINE, which is called REFERENCE LINE, is used instead of a zero-length THRU. The shortest LINE is used as the REFERENCE LINE. Its length must to be known, so that the calibration plane positions could be calculated exactly. However, LRL calibration is also possible when the REFERENCE LINE length is not known. In this case, its length is assumed to be equal to zero, the calibration plane being in the middle of the LINE, and not at the ports' edges.

### TRL LINE

TRL LINE is an airline used in TRL calibration, or the second longest LINE used in LRL calibration. The length of TRL LINE should be known just approximately. The LINE length is used to determine the calibration bandwidth. Let  $\Delta L$  be the difference between the two LINES in LRL calibration. In TRL calibration this difference will be equal to the LINE length, as a zero-length THRU is used as a REFERENCE LINE. Then the phase difference between the TRL LINE and REFERENCE LINE or THRU should be no less than 20° at the lower frequency and no more than 160° at the upper frequency of the calibration.

$$20 < \frac{360 \cdot f \cdot \Delta L}{v} < 160,$$

$$\Delta L = L_1 - L_0, \quad v - \text{wave velocity in LINE (for airline it is } c = 2.9979 \cdot 10^8 \text{ m/c)}.$$

$L_0$  – REFERENCE LINE length,  $L_1$  – TRL LINE length,

So, the useful frequency range for TRL/LRL calibration is 1:8. Besides, TRL/LRL calibration does not work at low frequencies, as it would require a very long LINE. Two or more TRL LINES are used to extend the calibration frequency. For example, in case of using two TRL LINES the frequency range can be increased up to 1:64.

### TRL MATCH

Unlike TRL/LRL calibration, TRM/LRM calibration uses MATCHes, which are the equivalent to the infinitely long LINE, instead of a TRL LINE. Theoretically TRM/LRM calibration has no frequency limitations. However, the use of TRM/LRM calibration at higher frequencies is limited by the quality of the MATCHes. As a

rule, the TRM/LRM calibration is used at lower frequencies, as it is good starting from zero frequency.

## **TRL REFLECT**

There are no strict requirements to the TRL REFLECT standard. You should know only approximate parameters of the TRL REFLECT standard. The REFLECT standard should have high reflection coefficient, close to 1. The phase of the standard must be known within  $\pm 90^\circ$ . Normally, any OPEN or SHORT meets this requirement. The next requirement is that the reflection coefficient must be the same for all the ports. If one standard is used for all the ports by turns, then this requirement is automatically fulfilled. If the ports have different genders or types of connectors, use special standards with the identical electrical specifications, which are available in pairs.

## **TRL Calibration Frequency Extension**

To extend the frequency of TRL calibration a method of dividing into several non-overlapping bands is applied. For each frequency band a separate TRL LINE of different length is used. The phase difference between each TRL LINE and the REFERENCE LINE must be from  $20^\circ$  to  $160^\circ$ , as indicated above. A MATCH standard is used in the lowest frequency band.

The Analyzer software allows using up to 8 LINES for calibration frequency extension. To achieve this, there are two steps of handling the calibration kits:

- defining frequency limits to calibration standards (see 5.3.2);
- assigning classes to calibration standards, where up to 8 calibration standards can be assigned to one class (see section 5.3.4).

Perform the above mentioned dividing of the calibration band into sub-bands and assign a separate TRL LINE to each of them in the calibration kit editing menu before calibration.

### **5.1.6.10 Multiline TRL Calibration (Planar 804/1 and S models)**

Regular TRL calibration, described in the previous section uses several LINES of different lengths for frequency extension. It is provided by the method of dividing the frequency band into separate sub-bands.

Multiline TRL calibration also uses several LINES. But it does not divide the frequency band into several sub-bands. Instead, all the LINES are used simultaneously over the whole calibration bandwidth. The redundancy of the LINES measurements allows for both extending the frequency range and increasing the calibration accuracy. The number of LINES should be no less than three. The more LINES you use, the higher the accuracy you will achieve.

To employ multiple LINES in the calibration procedure, use the same method of standards subclasses assignment as in the regular TRL calibration (see section 5.2.8.1). Defining frequency limits to calibration standards is not necessary for Multiline TRL calibration method. The procedure of switching between the normal and Multiline TRL calibrations see in section 5.2.7.1.

The following table shows the differences between the regular and Multiline TRL calibrations when entering the data into the calibration standards editing menu.

Calibration Standard	Data in Calibration Kit Manager	
	TRL	Multiline TRL
REFERENCE LINE or THRU	<ol style="list-style-type: none"> <li>1. Type: THRU/LINE</li> <li>2. Min and max frequency</li> <li>3. Delay*</li> <li>4. Class: TRL THRU</li> </ol>	<ol style="list-style-type: none"> <li>1. Type: THRU/LINE</li> <li>2. Delay*</li> <li>3. Class: TRL LINE/MATCH or TRL THRU</li> </ol>
LINE	<ol style="list-style-type: none"> <li>1. Type: THRU/LINE</li> <li>2. Min and max frequency</li> <li>3. Class: TRL LINE/MATCH</li> </ol>	The total number of LINES is no less than 3.
MATCH (optional)	<ol style="list-style-type: none"> <li>1. Type: MATCH</li> <li>2. Min and max frequency</li> <li>3. Class: TRL LINE/MATCH</li> </ol>	<ol style="list-style-type: none"> <li>1. Type: MATCH</li> <li>2. Class: TRL LINE/MATCH</li> </ol>
REFLECT	<ol style="list-style-type: none"> <li>1. Type: SHORT or OPEN</li> <li>2. Min and max frequency</li> <li>3. Model parameters, which allow calculating value of phase response within <math>\pm 90^\circ</math>.</li> <li>4. Class: TRL REFLECT</li> </ol>	

\* The delay for coaxial airlines is equal to  $\frac{L}{v}$ , where L is the length of the LINE, and v is the wave velocity in LINE equal to 2.9979·108 m/s.

## 5.1.7 Calibration Standards and Calibration Kits

Calibration standards are precision physical devices used for determination of errors in a measurement system.

A calibration kit is a set of calibration standards with a specific connector type and specific impedance.

The Analyzer provides definitions of calibration kits produced by different manufacturers. The user can add the definitions of own calibration kits or modify the predefined kits. Calibration kits editing procedure is described in the section 5.3.

To ensure the required calibration accuracy, select the calibration kit being used in the program menu. The procedure of calibration kit selection is described in section 5.2.1.

### 5.1.7.1 Definitions and Classes of Calibration Standards

Each calibration standard has a *definition* and belongs to one or several *classes*.

Calibration standard definition is a mathematical description of its parameters.

Calibration standard class is an application of the standard in a specific calibration method associated with a specific test port number. For example, "LOAD of Port 1" in full two-port calibration.

### 5.1.7.2 Types of Calibration Standards

Calibration standard type is a category of physical devices used to define the parameters of the standard. The Analyzer supports the following types of the calibration standards:

- OPEN,
- SHORT,
- FIXED LOAD,
- SLIDING LOAD,
- THRU/LINE,
- UNKNOWN TRHU (Planar 804/1 and S models only),
- Standard defined by data (S-parameters).



---

Note	The type of a calibration standard should not be confused with its class. Calibration standard type is a part of the standard definition used for the calculation of its parameters.
------	--

---

### 5.1.7.3 Gender of Calibration Standard

Gender of a calibration standard is typically denoted on the calibration standard label. The label and the gender of calibration standard respectively, are not accounted by the software and are used for user information only. Nevertheless, it is recommended to follow some rules for calibration standard gender designation. A calibration standard can be labeled either with:

- the gender of a calibration standard itself, as **-M-** for male and **-F-** for female type of standard; or
- the gender of the analyzer port, which the calibration standard is mated to, as (m) for male and (f) for female port types;

For example, same standard can be labeled as **Short -F-** or **Short (m)**.

The Analyzer software uses the first type of designation: the gender of a calibration standard itself denoted as **-M-** for male and **-F-** for female type of standards.

### 5.1.7.4 Methods of Calibration Standard Defining

The Analyzer provides two methods of defining a calibration standard:

- calibration standard model (See section 5.1.7.5),
- table of S-parameters (See section 5.1.7.6).

The calibration standards defined by the table of S-parameters are called *Data-Based standards*.

Besides, each calibration standard is characterized by lower and upper values of the operating frequency. In the process of calibration, the measurements of the calibration standards outside the specified frequency range are not used.

### 5.1.7.5 Calibration Standard Model

A model of a calibration standard presented as an equivalent circuit is used for determining of S-parameters of the standard. The model is employed for standards of OPEN, SHORT, FIXED LOAD, THRU/LINE types.

One-port model is used for the standards OPEN, SHORT, and FIXED LOAD (See 5.1.6.4).

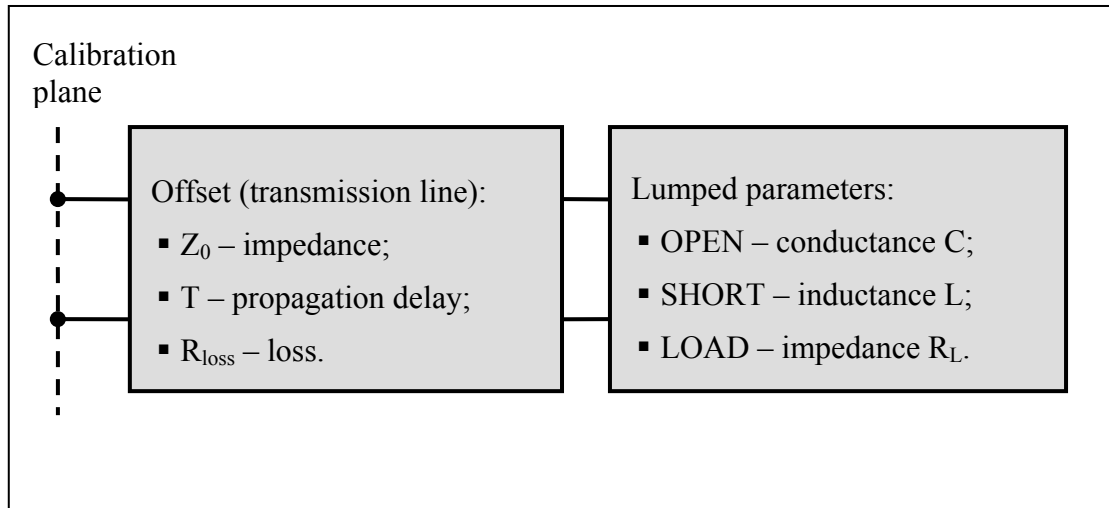

Figure 33 One-port standard model

Two-port model is used for the standard THRU/LINE (See Figure 34).

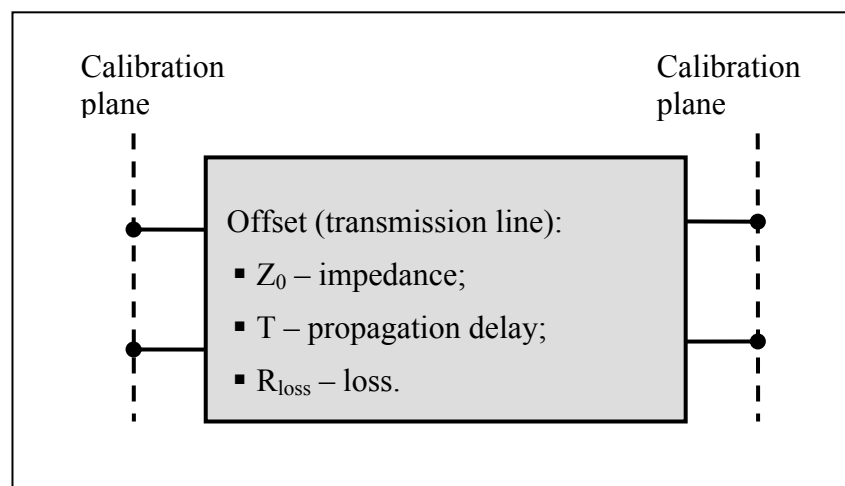

Figure 34 Two-port standard model

The description of the numeric parameters of an equivalent circuit model of a calibration standard is shown in Table 16.

Table 16 Parameters of the calibration standard equivalent circuit model

Parameter (as in the program)	Parameter Definition
<b>Z<sub>0</sub></b> <b>(Offset Z0)</b>	<p>For a one-port standard, it is the offset impedance (of a transmission line) between the calibration plane and the circuit with lumped parameters.</p> <p>For a two-port standard, it is the transmission line impedance between the two calibration planes.</p>
<b>T</b> <b>(Offset Delay)</b>	<p>The offset delay. It is defined as one-way propagation time (in seconds) from the calibration plane to the circuit with lumped parameters or to the other calibration plane. Each standard delay can be measured or mathematically determined by dividing the exact physical length by the propagation velocity.</p>
<b>R<sub>loss</sub></b> <b>(Offset Loss)</b>	<p>The offset loss in one-way propagation due to the skin effect. The loss is defined in Ω/sec at 1 GHz frequency. The loss in a transmission line is determined by measuring the delay T [sec] and loss L [dB] at 1 GHz frequency. The measured values are used in the following formula:</p> $Rn[\Omega/s] = \frac{L[dB] \cdot Z_0[\Omega]}{4.3429[dB] \cdot T[s]}$
<b>R<sub>load</sub></b> <b>(Load Impedance)</b>	<p>Load impedance in [Ω].</p>
<b>C</b> <b>(C0, C1, C2, C3)</b>	<p>The fringe capacitance of an OPEN standard, which causes a phase offset of the reflection coefficient at high frequencies. The fringe capacitance model is described as a function of frequency, which is a polynomial of the third degree:</p> $C = C_0 + C_1 f + C_2 f^2 + C_3 f^3$ <p>where f – frequency [Hz] C<sub>0</sub>...C<sub>3</sub> – polynomial coefficients Units: C<sub>0</sub>[F], C<sub>1</sub>[F/Hz], C<sub>2</sub>[F/Hz<sup>2</sup>], C<sub>3</sub>[F/Hz<sup>3</sup>]</p>

Table 17 Continued

<b>L</b> <b>(L0, L1,</b> <b>L2, L3)</b>	<p>The residual inductance of a SHORT standard, which causes a phase offset of the reflection coefficient at high frequencies. The residual inductance model is described as a function of frequency, which is a polynomial of the third degree:</p> $L = L_0 + L_1 f + L_2 f^2 + L_3 f^3, \text{ where}$ <p>f – frequency [Hz]  L<sub>0</sub>...L<sub>3</sub> – polynomial coefficients  Units: L<sub>0</sub>[H], L<sub>1</sub>[H/Hz], L<sub>2</sub>[H/Hz<sup>2</sup>], L<sub>3</sub>[H/Hz<sup>3</sup>]</p>
---	--

### 5.1.7.6 Data-Based Calibration Standards

The calibration standards defined by data are set using the table of S-parameters. Each line of the table contains frequency and S-parameters of the calibration standard. For one-port standards the table contains the value of only one parameter – S<sub>11</sub>, and for two-port standards the table contains the values of all the four parameters – S<sub>11</sub>, S<sub>21</sub>, S<sub>12</sub>, S<sub>22</sub>.

The table of S-parameters can be filled in manually by the user or downloaded from a file of Touchstone format. Files with \*.s1p extension are used for one-port standards, and files with \*.s2p extension are used for two-port standards.

### 5.1.7.7 Scope of Calibration Standard Definition

Different methods of calibration apply either full or partial definitions of the calibration standard kits.

The full two-port calibration, full one-port calibration, one-path two-port calibration, and normalization use fully defined calibration standards, i.e. the standards with known S-parameters. The S-parameters of OPEN, SHORT, LOAD, and THRU/LINE must be defined by the model or by data.

---

Note	The UNKNOWN THRU and SLIDING LOAD standards are exceptional in the above calibrations. The S-parameters of these standards are defined in the process of calibration. UNKNOWN THRU is used only in full two-port calibration.
------	---

---

TRL calibration and its modifications (TRM, LRL, LRM) apply partial definition of the standards:

- TRL THRU standards must have the required value of Z0 ( $S_{11}=S_{22}=0$ ) and known length (delay),
- TRL LINE/MATCH standard must have the same value of Z0 as the first standard,
- TRL REFLECT standard must have the phase known as accurately as  $\pm 90^\circ$ .

### 5.1.7.8 Classes of Calibration Standards

Along with defining a calibration standard by a calibration model or data, the standard should also be assigned a specific class. One calibration standard may belong to several classes. The class assignment is performed for each particular calibration kit. The procedure of class assignment to the calibration standards is described in section 5.3.4.

Class assignment to a calibration standards is required for specifying such properties as the calibration method, the role of a standard in the calibration, and the number of the port(s). The Analyzer supports the following classes of the calibration standards (See Table 18).

Table 18 Classes of the calibration standards

Calibration Methods	Class Label	Port
Full Two-Port Calibration	OPEN	1
		2
Full One-Port Calibration	SHORT	1
		2
One-Path Two-Port Calibration	LOAD	1
		2
Transmission Normalization	THRU	1-2
Reflection Normalization		
TRL Calibration	TRL THRU	1-2
LRL Calibration	TRL REFLECT	1
TRM Calibration		2
LRM Calibration	TRL LINE/MATCH	1-2

For example, if you assign the class "OPEN of Port 1" to the OPEN -F- calibration standard, it will indicate that this standard is used for calibrating the first port using the following calibration methods: full two-port, full one-port, one-path two-port, and normalization.

---

Note	Class assignment changes the labels of the calibration standards on the calibration softkeys.
------	---

---

### 5.1.7.9 Subclasses of Calibration Standards

Subclasses are used for assignment of one class to several calibration standards. The procedure of subclass assignment is mainly employed for calibration within a wide frequency range by several calibration standards, each of which does not cover the full frequency range. Each class of standards can contain up to 8 subclasses.

For example, suppose in your calibration kit the LOAD standard is defined as from 0 GHz to 2 GHz, and the sliding LOAD standard is defined as from 1.5 GHz to 12 GHz. To perform calibration within the full frequency range the fixed LOAD should be assigned the subclass 1, and the sliding LOAD should be assigned the subclass 2 of the "load" class.

If the standards have an overlapping frequency range (as in the example above, from 1.5 GHz to 2 GHz), the last measured standard will be used.

---

Note	Subclass assignment changes the labels of the calibration softkeys. The measurement softkey is replaced by the key, which opens the subclass menu containing the keys for measuring several calibration standards.
------	--

---

## 5.2 Calibration Procedures

### 5.2.1 Calibration Kit Selection

The calibration kit employed during a calibration should be selected according to the following procedure. If it is not specified in the list of the predefined calibration kits, you should add it. The procedure of adding and editing of the calibration kits is described in the section 5.3.

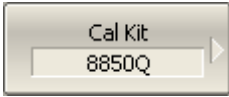

  

To open the list of the calibration kits (See Figure 35), use the following softkeys:

**Calibration > Cal Kit**

	Label	Description	Select	Predefined	Modified	#STDs	
2	85032B/E	Type-N 50Ω 6GHz Cal Kit (Agilent)	<input type="checkbox"/>	Yes	No	6	
3	85032F	Type-N 50Ω 9GHz Cal Kit (Agilent)	<input type="checkbox"/>	Yes	No	8	
4	85054B	Type-N 50Ω 18GHz Cal Kit with Sliding Load (Agilent)	<input type="checkbox"/>	Yes	No	8	
5	85054D	Type-N 50Ω 18GHz Cal Kit (Agilent)	<input type="checkbox"/>	Yes	No	6	
6	05CK10A-150	Type-N 50Ω 18GHz Cal Kit (Rosenberger)	<input type="checkbox"/>	Yes	No	6	
7	8850Q	Type-N 50Ω 18GHz Cal Kit (Maury Microwave)	<input checked="" type="checkbox"/>	Yes	No	6	
8	8850C	Type-N 50Ω 18GHz Cal Kit with Sliding Load (Maury Micro)	<input type="checkbox"/>	Yes	No	8	
9	85033D/E	3.5 mm 6GHz/9GHz Cal Kit (Agilent)	<input type="checkbox"/>	Yes	No	6	
10	85052B	3.5 mm 26.5GHz Cal Kit with Sliding Load (Agilent)	<input type="checkbox"/>	Yes	No	10	

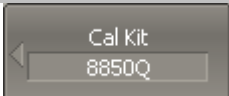
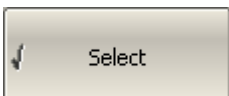
Figure 35 The list of calibration kits

Highlight the required line in the list of the calibration kits and use the following softkey:

**Select**

Or click on the checkbox in the row "Select" by the mouse.

**Note** Make sure that the selected calibration kit is check marked.

## 5.2.2 Reflection Normalization

Reflection normalization is the simplest calibration method used for reflection coefficient measurements ( $S_{11}$  or  $S_{22}$ ). Only one standard (SHORT or OPEN) is measured (See Figure 36) in the process of this calibration. You can also perform directivity calibration by measuring a LOAD standard.

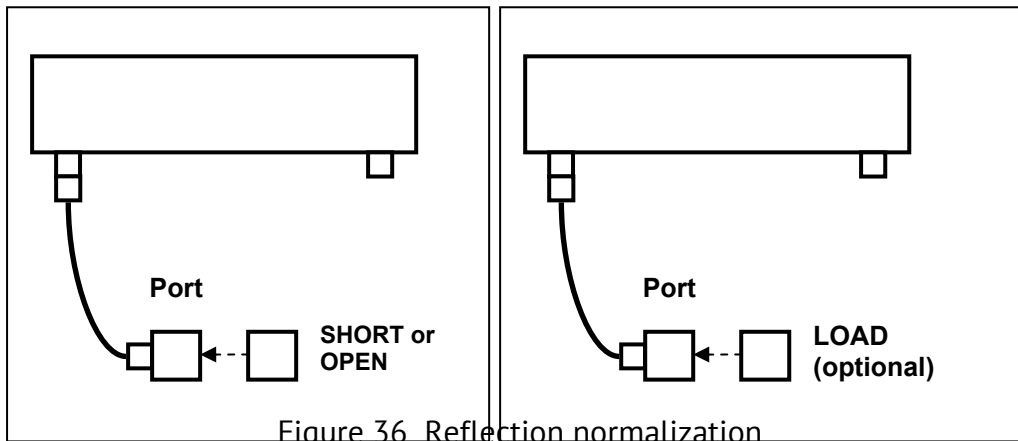

Before starting calibration perform the following settings: select active channel, set the parameters of the channel (frequency range, IF bandwidth, etc.), and select the calibration kit.



To open reflection normalization submenu, use the following softkeys:

**Calibration > Calibrate > Response (Open) | Response (Short)**

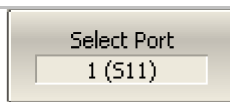

Select the test port to be calibrated using **Select Port**. Clicking this softkey you can switch between the test ports (measured parameters).

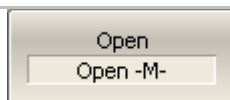

Connect an OPEN or a SHORT standard to the test port as shown in Figure 36. Perform measurement using **Open** or **Short** softkey respectively.

The instrument status bar will indicate **Calibration in progress...** when the measurement is in progress. On completion of the measurement, a check mark will appear in the left part of the softkey.

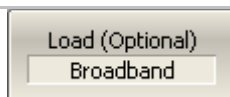

To perform the optional directivity calibration, connect a LOAD standard to the test port as shown in Figure 36 and perform measurement using **Load (Optional)** softkey.

The instrument status bar will indicate **Calibration in progress...** when the measurement is in progress. On completion of the measurement a check mark will appear in the left part of the softkey.



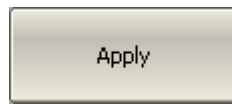

---

To complete the calibration procedure, click **Apply**.

This will activate the process of calibration coefficient table calculation and saving it into the memory. The error correction function will also be automatically enabled.

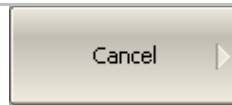

---

To clear the measurement results of the standards, click **Cancel**.

This softkey does not cancel the current calibration. To disable the current calibration turn off the error correction function (See section 5.2.10).

---

Note

You can check the calibration status in channel status bar (See Table 19) or in trace status field (See Table 20).

---

### 5.2.3 Transmission Normalization

Transmission normalization is the simplest calibration method used for transmission coefficient measurements ( $S_{21}$  or  $S_{12}$ ). One THRU standard is measured (See Figure 37) in the process of this calibration. You can also perform isolation calibration by measuring two LOAD standards.

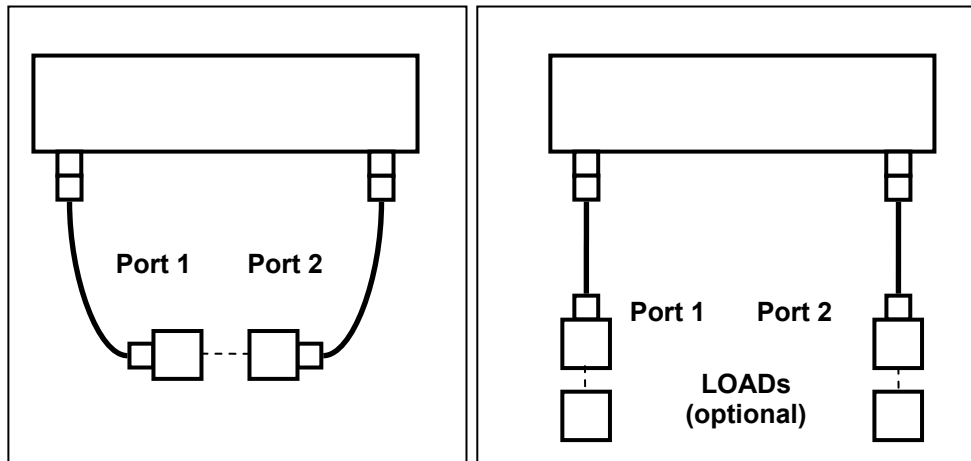

Figure 37 Transmission normalization

Before starting calibration perform the following settings: select active channel, set the parameters of the channel (frequency range, IF bandwidth, etc.), and select the calibration kit.



To open transmission normalization submenu, use the following softkeys:

**Calibration > Calibrate > Response (Thru)**

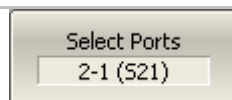

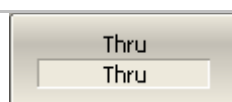

Select the direction of the calibration using **Select Ports** softkey. The label on the softkey indicates the following: receiver port – source port (measured parameter).

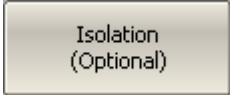

Connect a THRU standard between the test ports. If the port connectors allow through connection connect them directly (zero electrical length thru). Perform measurement using **Thru** softkey.

The instrument status bar will indicate **Calibration in progress...** when the measurement is in progress. On completion of the measurement a check mark will appear in the left part of the softkey.

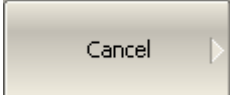
	<p>To perform the optional isolation calibration, connect two LOAD standards to the test ports as shown in Figure 37 and enable measurement using <b>Isolation (Optional)</b> softkey.</p> <p>The instrument status bar will indicate <b>Calibration in progress...</b> when the measurement is in progress. On completion of the measurement a check mark will appear in the left part of the softkey.</p>
	<p>To complete the calibration procedure, click <b>Apply</b>.</p> <p>This will activate the process of calibration coefficient table calculation and saving it into the memory. The error correction function will also be automatically enabled.</p>
	<p>To clear the measurement results of the standard, click <b>Cancel</b>.</p> <p>This softkey does not cancel the current calibration. To disable the current calibration, turn off the error correction function (See section <b>Ошибка! Источник ссылки не найден.</b>).</p>
<p>Note</p>	<p>You can check the calibration status in channel status bar (See Table 19) or in trace status field (See Table 20).</p>

## 5.2.4 Full One-Port Calibration

Full one-port calibration is used for reflection coefficient measurements ( $S_{11}$  or  $S_{22}$ ). The three calibration standards (SHORT, OPEN, LOAD) are measured (See

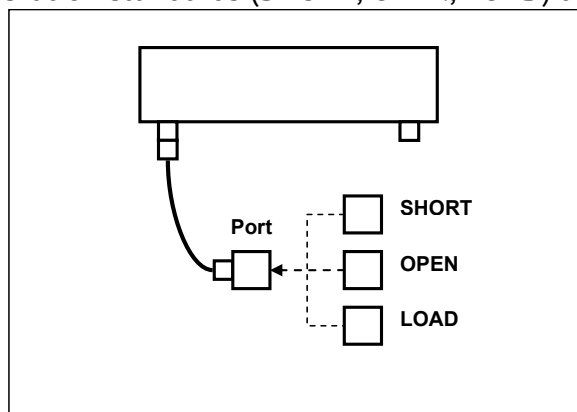

Figure 38) in the process of this calibration.

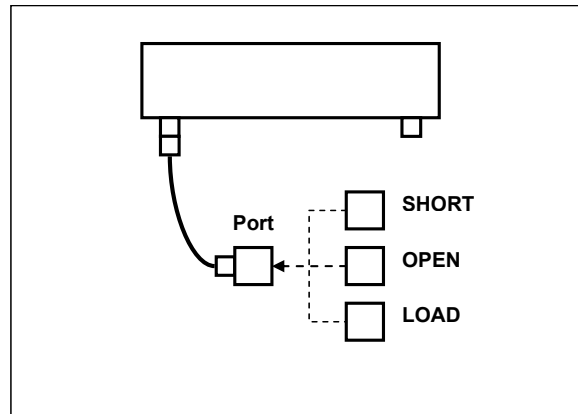

Figure 38 Full one-port calibration

Before starting calibration perform the following settings: select active channel, set the parameters of the channel (frequency range, IF bandwidth, etc.), and select the calibration kit.



To open full one-port calibration submenu, use the following softkeys:

**Calibration > Calibrate > Full 1-Port Cal**

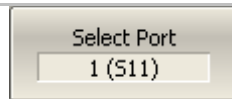

Select the test port to be calibrated using **Select Port**. Clicking this softkey you can switch between the test ports (measured parameters).

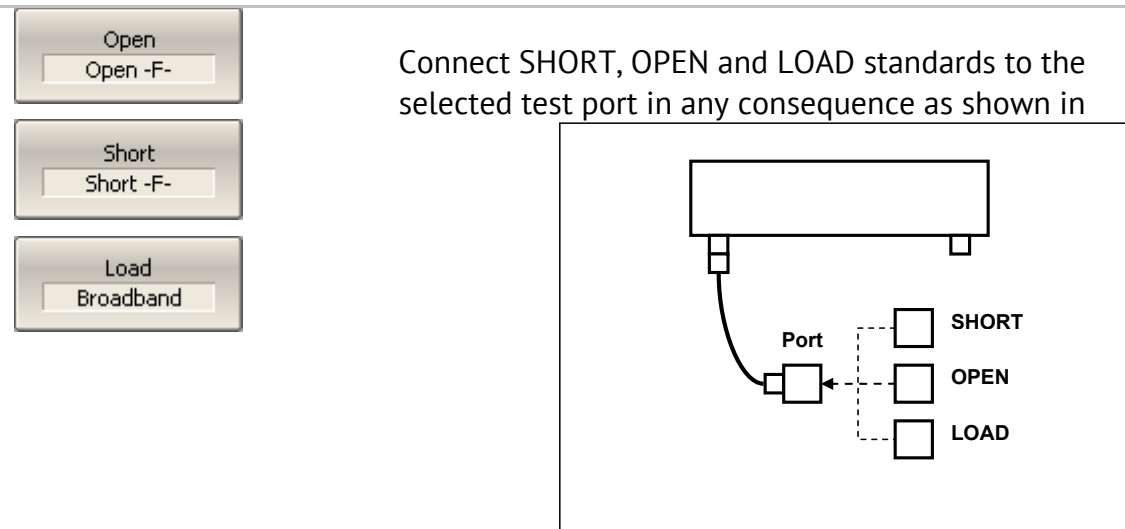

Figure 38. Perform measurements clicking the softkey corresponding to the connected standard.

The instrument status bar will indicate **Calibration in progress...** when the measurement is in progress. On completion of the measurement a check mark will appear in the left part of the softkey.

	<p>To complete the calibration procedure, click <b>Apply</b>.</p>
<p>This will activate the process of calibration coefficient table calculation and saving it into the memory. The error correction function will also be automatically enabled.</p>	
	<p>To clear the measurement results of the standards, click <b>Cancel</b>.</p>
<p>This softkey does not cancel the current calibration. To disable the current calibration, turn off the error correction function (See section 5.2.10).</p>	
<p>Note</p>	<p>You can check the calibration status in channel status bar (See Table 19) or in trace status field (See Table 20).</p>

### 5.2.5 One-Path Two-Port Calibration

One-path two-port calibration is used for measurements of the DUT parameters in one direction, e.g.  $S_{11}$  and  $S_{21}$ . This method involves connection of the three calibration standards to the source port, and connection of a THRU standard between the calibrated source port and the other receiver port (See Figure 39). You can also perform isolation calibration by measuring two LOAD standards.

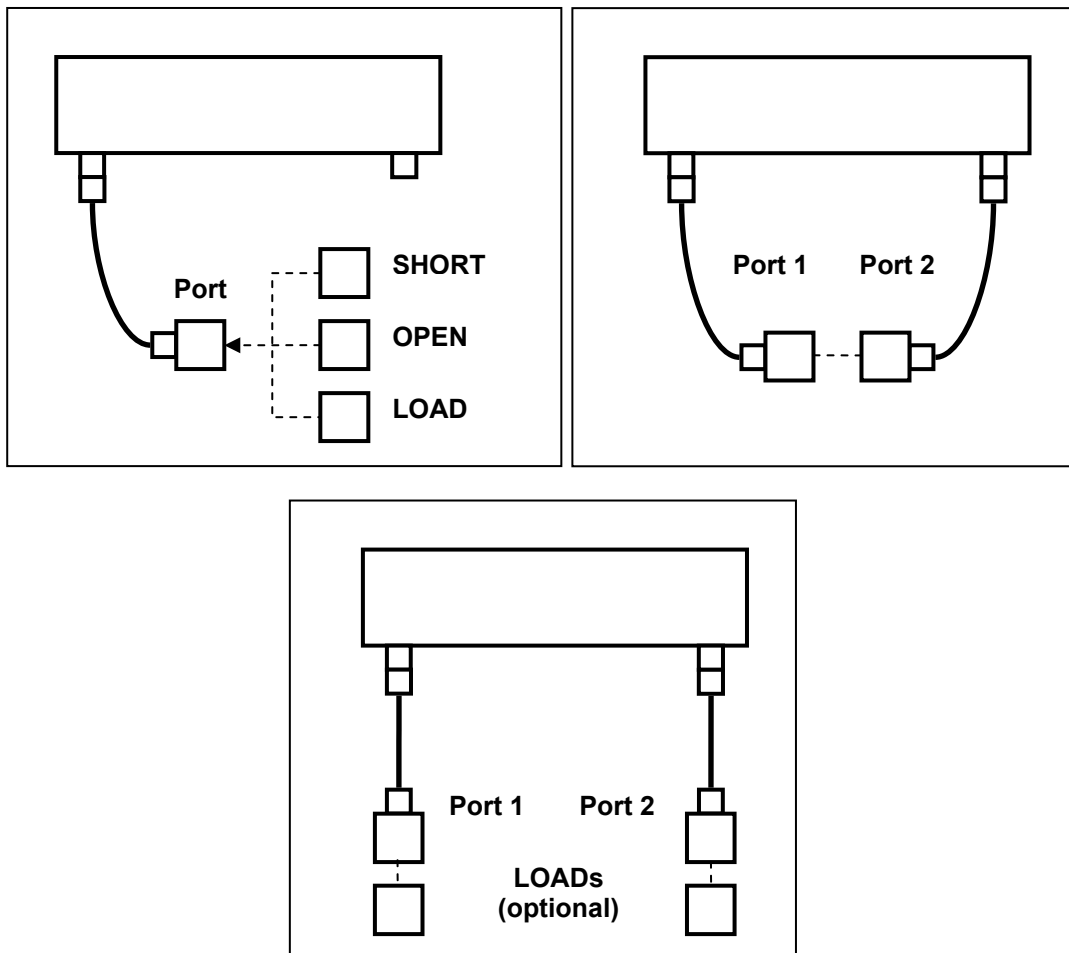



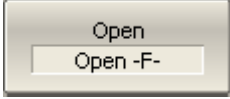

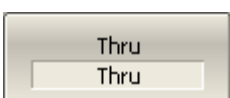
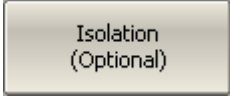

Figure 39 One-path two-port calibration

Before starting calibration perform the following settings: select active channel, set the parameters of the channel (frequency range, IF bandwidth, etc.), and select the calibration kit.



To open one-path two-port calibration submenu, use the following softkeys:

**Calibration > Calibrate > One Path 2-Port Cal**

	<p>Select the direction of the calibration using <b>Select Ports</b> softkey. The label on the softkey indicates the following: receiver port – source port (measured parameters).</p>
   	<p>Connect SHORT, OPEN and LOAD standards to the source port in any consequence, as shown in Figure 39. Perform measurements clicking the softkey corresponding to the connected standard.</p> <p>Connect a THRU standard between the test ports. If the port connectors allow through connection connect them directly (zero electrical length thru). Perform measurement using <b>Thru</b> softkey.</p> <p>The instrument status bar will indicate <b>Calibration in progress...</b> when the measurement is in progress. On completion of the measurement a check mark will appear in the left part of the softkey.</p>
	<p>To perform the optional isolation calibration, connect two LOAD standards to the test ports as shown in Figure 39 and enable measurement using <b>Isolation (Optional)</b> softkey.</p> <p>The instrument status bar will indicate <b>Calibration in progress...</b> when the measurement is in progress. On completion of the measurement a check mark will appear in the left part of the softkey.</p>
	<p>To complete the calibration procedure, click <b>Apply</b>.</p> <p>This will activate the process of calibration coefficient table calculation and saving it into the memory. The error correction function will also be automatically enabled.</p>
	<p>To clear the measurement results of the standards, click <b>Cancel</b>.</p> <p>This softkey does not cancel the current calibration. To disable the current calibration, turn off the error correction function (See section 5.2.10).</p>

Note	You can check the calibration status in channel status bar (See Table 19) or in trace status field (See Table 20).
------	--

### 5.2.6 Full Two-Port Calibration

Full two-port calibration combines two one-port calibrations for each test port with measurement of transmission and reflection of a THRU standard in both directions (See Figure 40). You can also perform isolation calibration by measuring two LOAD standards.

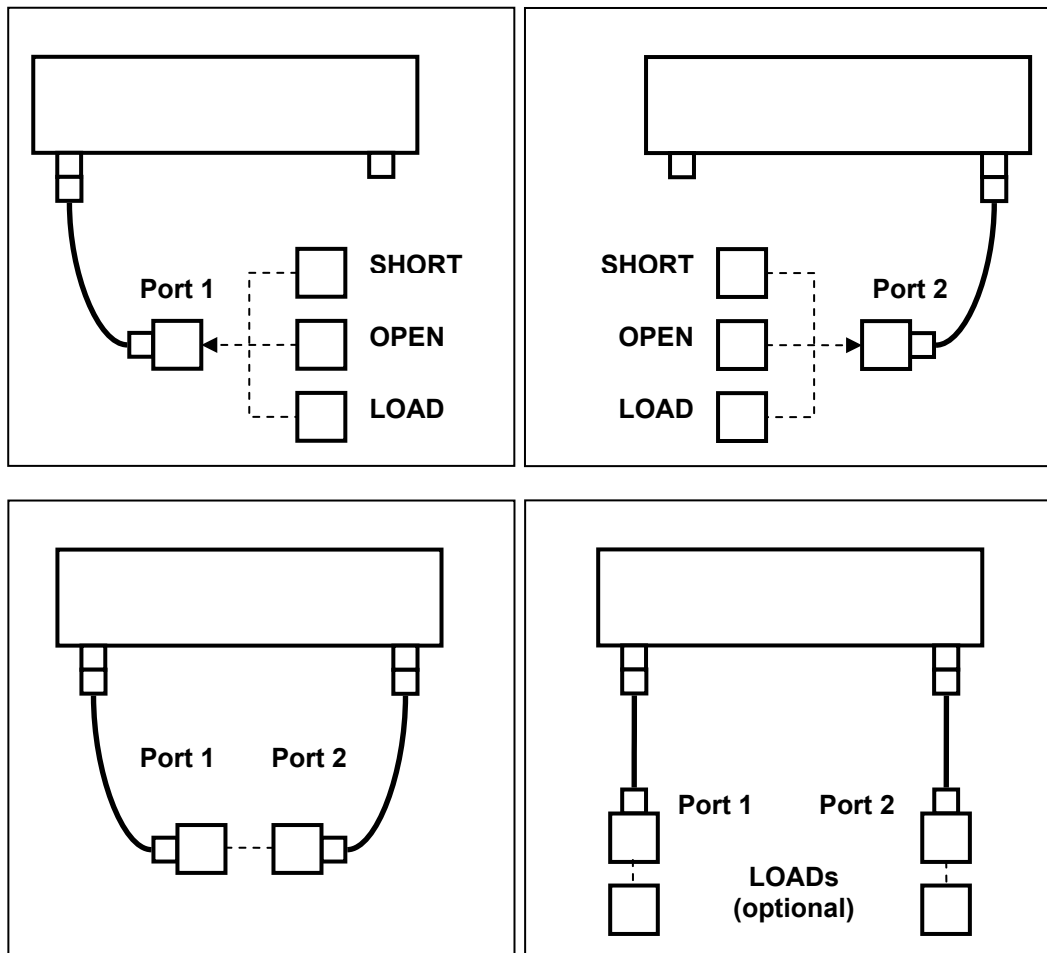
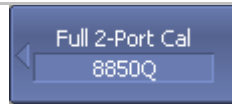

Figure 40 Full two-port calibration

Before starting calibration perform the following settings: select active channel, set the parameters of the channel (frequency range, IF bandwidth, etc.), and select the calibration kit.





To open full two-port calibration submenu, use the following softkeys:

**Calibration > Calibrate > Full 2-Port Cal**

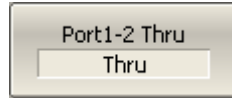
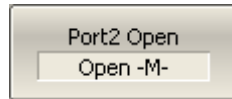
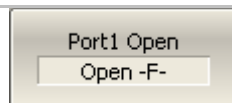

Connect SHORT, OPEN and LOAD standards to the 1 and 2 ports in any consequence, as shown in Figure 40. Perform measurements clicking the softkey corresponding to the connected standard.

Connect a THRU standard between the test ports. If the port connectors allow through connection connect them directly (zero electrical length thru). Perform measurement using **Port 1-2 Thru** softkey.

The instrument status bar will indicate **Calibration in progress...** when the measurement is in progress. On completion of the measurement a check mark will appear in the left part of the softkey.

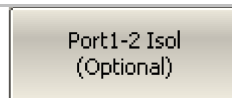

To perform the optional isolation calibration, connect two LOAD standards to the test ports as shown in Figure 40 and enable measurement using **Port 1-2 Isol (Optional)** softkey.

The instrument status bar will indicate **Calibration in progress...** when the measurement is in progress. On completion of the measurement a check mark will appear in the left part of the softkey.

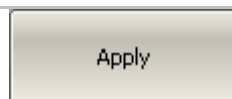

To complete the calibration procedure, click **Apply**.

This will activate the process of calibration coefficient table calculation and saving it into the memory. The error correction function will also be automatically enabled.

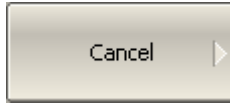

To clear the measurement results of the standards, click **Cancel**.

This softkey does not cancel the current calibration. To disable the current calibration, turn off the error correction function (See section 5.2.10).

---

Note	You can check the calibration status in channel status bar (See Table 19) or in trace status field (See Table 20).
------	--

---

### 5.2.6.1 Unknown Thru Calibration (Planar 804/1 and S models only)

The unknown thru calibration procedure is same as the one for a full two-port calibration described in the previous section.

To start unknown thru calibration, first add UNKNOWN THRU standard to the description of the calibration kit and assign the class to it. After that, the unknown thru measurement softkey will become available in the two-port calibration menu.

See section 5.3.2 for a calibration standard definition in a calibration kit. When adding the unknown thru standard to a kit you should specify just two parameters: UNKNOWN THRU type of the standard and approximate delay of propagation in one direction. You can enter zero value for delay for it to be automatically determined during calibration (See section 5.1.6.8).

See section 5.3.4 for the calibration standard class assignment. A newly added UNKNOWN THRU standard is to be assigned to “Thru, Port 1-2” class.

### 5.2.7 TRL Calibration (Planar 804/1 and S models)

TRL calibration is the most accurate calibration method for two-port measurements (See Figure 41):

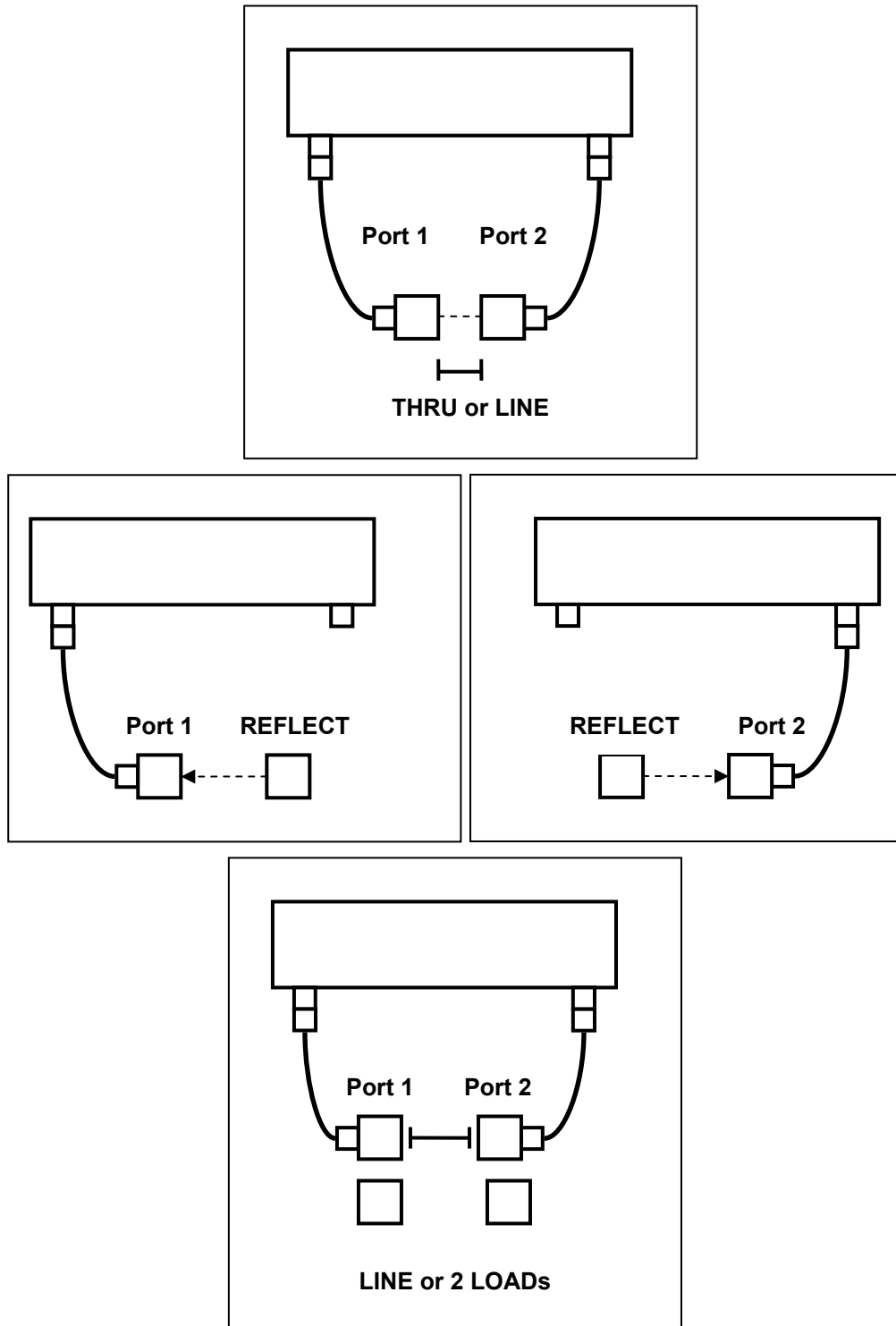

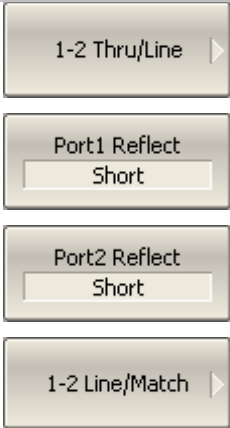

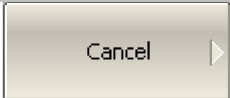

Figure 41 TRL calibration

Before starting calibration, perform the following settings: select active channel, set the parameters of the channel (frequency range, IF bandwidth, etc.), select the calibration kit.

	<p>To open TRL calibration submenu, use the following softkeys:</p> <p><b>Calibration &gt; Calibrate &gt; 2-Port TRL Cal</b></p>
	<p>Connect a TRL THRU (THRU or LINE) standard between the test ports. Perform measurement using <b>1-2 Thru/Line</b> softkey.</p> <p>Connect a TRL REFLECT standard to the test ports in any order. Perform measurement using <b>Port 1 Reflect</b> and <b>Port 2 Reflect</b> softkey.</p> <p>Connect a TRL LINE/MATCH (LINE between the test ports and 2 LOADs to each port). Perform measurement using <b>Port 1-2 Line/Match</b> softkey.</p> <p>The instrument status bar will indicate <b>Calibration in progress...</b> when the measurement is in progress. On completion of the measurement a check mark will appear in the left part of the softkey.</p>
	<p>To complete the calibration procedure, click <b>Apply</b>.</p> <p>This will activate the process of calibration coefficient table calculation and saving it into the memory. The error correction function will also be automatically enabled.</p>
<p>Note</p>	<p>System correction will turn automatically off when you press <b>Apply</b> softkey to perform TRL calibration (See section 8.4).</p>
	<p>To clear the measurement results of the standards, click <b>Cancel</b>.</p> <p>This softkey does not cancel the current calibration. To disable the current calibration, turn off the error correction function (See section 5.2.10).</p>

---

Note	You can check the calibration status in channel status bar (See Table 19) or in trace status field (See Table 20).
------	--

---

### 5.2.7.1 Multiline Option of TRL Calibration

This section pertains to Planar 804/1 and S-classes only. The procedure of Multiline TRL calibration is the same as the procedure of TRL calibration described above. The number of the LINES of various lengths should be no less than three.

First of all create and edit the calibration kit for the Multiline TRL calibration. For details on the data to be entered for the normal and Multiline TRL calibrations see section 5.1.6.10.

Switching between the normal and Multiline TRL calibrations is performed by a specific button in TRL calibration menu.

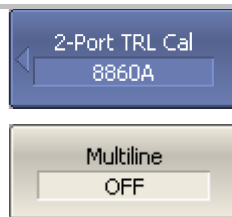

To toggle between normal and Multiline TRL calibrations, use **Multiline** softkey.

## 5.2.8 Calibration Using Subclasses

When several calibration standards of one class are used for calibration, you should assign subclasses to these standards using the calibration kit editing function. The procedure of subclass assignment is described in section 5.3.4.

When assigning two or more subclasses to one class of calibration standards, the standard measurement softkey is replaced by the softkey, which opens the subclass menu containing the list of all the standards of this class.

### 5.2.8.1 TRL Calibration Example Using Subclasses

This section pertains to Planar 804/1 and S-classes only. It describes an example of calibration using the calibration kit for TRL calibration, in which the "TRL LINE/MATCH" class contains 3 subclasses: load (Lowband), line 2 (TRL Line2), and line 3 (TRL Line3).

1-2 Line/Match  
 05CK120-150

In the main menu of TRL calibration the **1-2 Line/Match** softkey will open the subclass menu (if the above mentioned condition is met).

Subclass 1  
 Lowband

Connect the Lowband, Line2 and Line3 to the test ports in any consequence and perform measurements clicking the softkey corresponding to the connected standard.

Subclass 2  
 Line2

Subclass 3  
 Line3

Info

If two standards have an overlapping frequency range the last measured standard will be used in the overlapping region.

To view additional information about each standard frequency range, in which its measurements are applied (See Figure 42), press **Info** softkey.

1-2 Line/Match	Used in Calculations	STD Label	Applied to Range	
			Fmin	Fmax
Subclass 1	<input checked="" type="checkbox"/>	Lowband	300 kHz	680.2745 MHz
Subclass 2	<input checked="" type="checkbox"/>	Line2	3.600165 GHz	8 GHz
Subclass 3	<input checked="" type="checkbox"/>	Line3	720.273 MHz	3.5601665 GHz
Subclass 4	<input type="checkbox"/>			
Subclass 5	<input type="checkbox"/>			
Subclass 6	<input type="checkbox"/>			
Subclass 7	<input type="checkbox"/>			

Measurement: Ready

Figure 42 Information on calibration standard measurements.

### 5.2.8.2 Sliding Load Calibration Example Using Subclasses

This section describes an example of calibration using the calibration kit 85054B, in which the "load" class contains 3 subclasses: fixed low-frequency load (Lowband), sliding load (Sliding), and fixed broadband load (Broadband). Only first two standards are used for calibration.

Port 1 Load  
85054B

In the main calibration menu the **Load** softkey will open the subclass menu (if the above mentioned condition is met).

Subclass 1  
Lowband

Connect Lowband and Sliding Load standards to the 1 port in any consequence and perform measurements clicking the softkey corresponding to the connected standard. To measure the Lowband, press **Lowband** softkey, and to measure the Sliding Load, press **Sliding Load** softkey. The procedure of sliding load measurement is described in detail in section 5.2.8.2.

Subclass 2  
Sliding Load

Info

If two standards have an overlapping frequency range the last measured standard will be used in the overlapping region.

To view additional information about each standard frequency range, in which its measurements are applied (See Figure 44), press **Info** softkey.

Port 1 Load	Used in Calculations	STD Label	Applied to Range	
			Fmin	Fmax
Subclass 1	<input checked="" type="checkbox"/>	Lowband	300 kHz	1.984114 GHz
Subclass 2	<input checked="" type="checkbox"/>	Sliding Load	2.0001125 GHz	3.2 GHz
Subclass 3	<input type="checkbox"/>	Broadband		
Subclass 4	<input type="checkbox"/>			
Subclass 5	<input type="checkbox"/>			
Subclass 6	<input type="checkbox"/>			
Subclass 7	<input type="checkbox"/>			

Measurement: Ready





Figure 43 Information on calibration standard measurements.

### 5.2.9 Calibration Using Sliding Load

The SLIDING LOAD can be used instead of a FIXED LOAD in full one-port and two-port calibrations.

If a calibration kit contains a SLIDING LOAD, the standard measurement softkey is replaced by the softkey, which opens the submenu containing the SLIDING LOAD calibration logic.

The sliding load calibration involves a series of measurements in different positions of the sliding element. The minimum number of measurements is 5, the maximum number of measurements is 8.

	<p>In the main menu of one-port or two-port calibration the <b>Load</b> softkey will open the sliding load menu (if the above mentioned condition is met).</p>
	<p>Connect the SLIDING LOAD to a selected test ports and perform a series of measurements in different positions of the sliding element clicking the <b>Position 1, Position 2 ... Position 8</b> softkeys.</p>
	
	

#### Note

The sliding load had a low cutoff frequency. To perform calibration in the full frequency range, use two loads: FIXED LOAD standard in the lower part of the frequency range, and SLIDING LOAD in the upper frequency range using subclasses (See section 5.2.8.2).

### 5.2.10 Error Correction Disabling

This feature allows the user to disable the error correction function, which automatically becomes enabled after completion of calibration by any method.

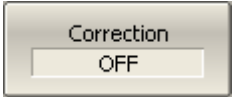
	<p>To disable and enable again the error correction function, use the following softkeys:</p>
	<p><b>Calibration &gt; Correction</b></p>



### 5.2.11 Error Correction Status

The error correction status is indicated for each trace individually. Also there is a general status of error correction for all the traces of a channel.

The general error correction status for all the S-parameter traces of a channel is indicated in the specific field on a channel status bar (See Table 19). For channel status bar description, see section 4.2.6.

Table 19 General error correction status

Symbol	Definition	Note
<b>Cor</b>	Error correction is enabled. The stimulus settings are the same for the measurement and the calibration.	If the function is active for all the traces – black characters on a gray background.
<b>C?</b>	Error correction is enabled. The stimulus settings are not the same for the measurement and the calibration.	
<b>C!</b>	Error correction is enabled. The stimulus settings are not the same for the measurement and the calibration. Extrapolation is applied.	
<b>Off</b>	Error correction is turned off.	For all the traces. White characters on a red background.
---	No calibration data. No calibration was performed.	

The error correction status for each individual trace is indicated in the trace status field (See Table 20). For trace status field description, see section 4.2.2.

Table 20 Trace error correction status

Symbols	Definition
<b>RO</b>	OPEN response calibration
<b>RS</b>	SHORT response calibration
<b>RT</b>	THRU response calibration
<b>OP</b>	One-path 2-port calibration
<b>F1</b>	Full 1-port calibration
<b>F2</b>	Full 2-port or TRL calibration

### 5.2.12 System Impedance $Z_0$

$Z_0$  is the system impedance of a measurement path. Normally it is equal to the impedance of the calibration standards, which are used for calibration. The  $Z_0$  value should be specified before calibration, as it is used for calibration coefficient calculations.

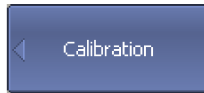

To set the system impedance  $Z_0$ , use the following softkeys:

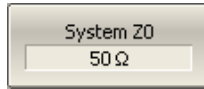

**Calibration > System Z0**

#### Note

Selection of calibration kit automatically determines the system impedance in accordance with the value specified for the kit.

### 5.2.13 Port Extension

The port extension function enables you to eliminate the fixture (with or without losses) effects on the measurement results. The function virtually extends the test ports moving the calibration plane to the terminals of the DUT (by the length of the fixture). The fixture parameters are defined by the user for each port individually (See Figure 44).

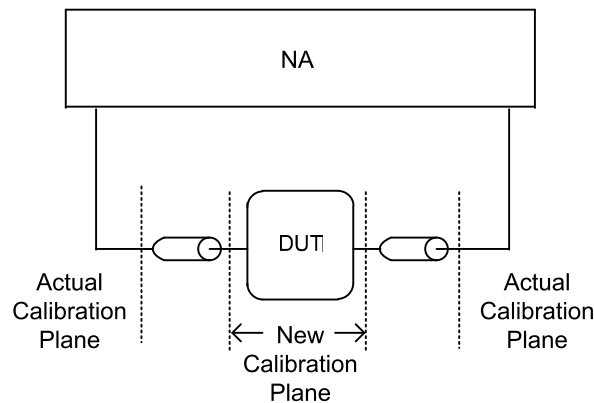

Figure 44 Port extension

The phase incursion caused by electrical delay is compensated for, when a lossless fixture needs to be removed:

$$e^{j \cdot 2 \pi \cdot f \cdot t}, \quad \text{where}$$

$f$  – frequency, Hz,

$t$  – electrical delay, sec.

The feature of removing a lossless fixture is similar to the feature of electrical delay setting for a trace (See section 4.9.7), but unlike the latter it applies to all the traces of the channel. It compensates for a fixture length in transmission measurements and for a double fixture length in reflection measurements.

To remove a fixture with losses, the following methods of loss defining (in one, two or three frequency points) are applied:

1. Frequency-independent loss at DC -  $L_0$

$$L(f) = L_0$$

2. Frequency-dependent loss determined by the losses in two frequency points:  $L_0$  at DC, and  $L_1$  at frequency  $F_1$

$$L(f) = L_0 + (L_1 - L_0) \sqrt{\frac{f}{F_1}}$$

3. Frequency-dependent loss determined by the losses in three frequency points:  $L_0$  at DC,  $L_1$  at frequency  $F_1$ , and  $L_2$  at frequency  $F_2$

$$L(f) = L_0 + (L_1 - L_0) \left( \frac{f}{F_1} \right)^n,$$

$$n = \frac{\log \left| \frac{L_1}{L_2} \right|}{\log \frac{F_1}{F_2}}$$

### 5.3 Calibration Kit Management

This section describes how to edit the calibration kit description, add and delete a calibration kit.

The Analyzer provides a table for 50 calibration kits. The first part of the table contains the predefined kits. The second part of the table is for calibration kit added by the user.

A calibration kit redefining can be required for the following purposes:

- To change the port assignment of a standard to ensure connector type (male, female) matching;
- To add a user-defined standard into the kit, e.g. a non-zero-length thru;
- To precise the standard parameters to improve the calibration accuracy.

A new user-defined calibration kit adding can be added when a required kit is not included in the list of the predefined kits.

Deleting function is available for user-defined calibration kits only.

Any changes made to the calibration kits are automatically saved into the nonvolatile memory of the Analyzer. For the saving no clicking on a “Save” button is required.

---

Note	Changes to a predefined calibration kit can be cancelled any time and the initial state will be restored.
------	---

---

#### 5.3.1 Table of Calibration Kits

The table of calibration kits (See Figure 45) allows selecting and editing of the calibration kits.

	Label	Description	Select	Predefined	Modified	#STDs	
2	85032B/E	Type-N 50Ω 6GHz Cal Kit (Agilent)	<input type="checkbox"/>	Yes	No	6	
3	85032F	Type-N 50Ω 9GHz Cal Kit (Agilent)	<input type="checkbox"/>	Yes	No	8	
4	85054B	Type-N 50Ω 18GHz Cal Kit with Sliding Load (Agilent)	<input type="checkbox"/>	Yes	No	8	
5	85054D	Type-N 50Ω 18GHz Cal Kit (Agilent)	<input type="checkbox"/>	Yes	No	6	
6	05CK10A-150	Type-N 50Ω 18GHz Cal Kit (Rosenberger)	<input type="checkbox"/>	Yes	No	6	
7	8850Q	Type-N 50Ω 18GHz Cal Kit (Maury Microwave)	<input checked="" type="checkbox"/>	Yes	No	6	
8	8850C	Type-N 50Ω 18GHz Cal Kit with Sliding Load (Maury Micr	<input type="checkbox"/>	Yes	No	8	
9	85033D/E	3.5 mm 6GHz/9GHz Cal Kit (Agilent)	<input type="checkbox"/>	Yes	No	6	
10	85052B	3.5 mm 26.5GHz Cal Kit with Sliding Load (Agilent)	<input type="checkbox"/>	Yes	No	10	

Figure 45 Table of calibration kits

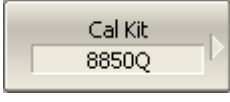
	<p>To open the table of calibration kits, use the following softkeys:</p>
	<p><b>Calibration &gt; Cal Kit</b></p>

To edit a calibration kit, highlight its line in the table.

The calibration kit editing is comprised of two main procedures: defining of calibration standard (sections 5.3.2 and 5.3.3) and assignment of classes to calibration standards (section 5.3.4). First you need to perform defining of the calibration standards, and then the assignment of classes to them. Defining of calibration standards and assignment of classes to them is performed in different tables.

The label of a calibration kit and its description can be edited in the table of the calibration kits (Figure 45). The label appears on the calibration menu softkeys. The description is just for information of the user.

The table also contains display-only fields: flags of predefined and modified calibration kits and the counter of the calibration standards in a kit.

### 5.3.1.1 Calibration Kit Selection for Editing

Move the highlighting to the required line in the calibration kit (See Figure 45) table using “↑” and “↓” arrows.

<p>Note</p>	<p>The checkmark in the “Select” field does not matter for the kit selection for editing, it selects the calibration kit for calibration.</p>
-------------	---

### 5.3.1.2 Calibration Kit Label and Description Editing

Move the highlighting to the required line in the calibration kit (See Figure 45) table using “↑” and “↓” arrows and click on the «Enter» softkey. Then enter the new text in the table.

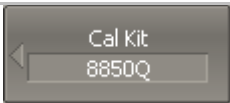
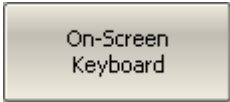
	<p>To activate the on-screen keyboard, click <b>On-Screen Keyboard</b> softkey.</p>
	

### 5.3.1.3 Predefined Calibration Kit Restoration

Move the highlighting to the required line in the calibration kit (See Figure 45).

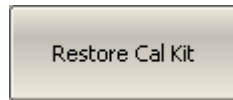
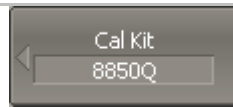

To cancel the user changes of a predefined calibration kit, use the following softkeys:

**Restore Cal Kit**

Note

It is possible to restore only such calibration kits, whose “Predefined” and “Modified” fields have “Yes” labeling.

### 5.3.1.4 User-Defined Calibration Kit Deleting

Move the highlighting to the required line in the calibration kit (See Figure 45).

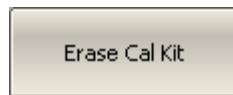
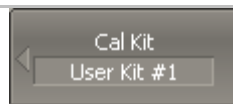

To delete a user-defined calibration kit from the table, use the following softkey:

**Erase Cal Kit**

Note

It is possible to delete only such calibration kits, whose “Predefined” field have “No” labeling.

### 5.3.1.5 Calibration Kit Saving to File

Saving of a calibration kit to file is necessary for copying it to a different line of the table or to a different Analyzer.

This command is not necessary for saving of changes made by the user to the definitions of the kit as these changes are saved automatically.

Move the highlighting to the required line in the calibration kit (See Figure 45).

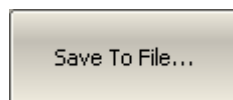
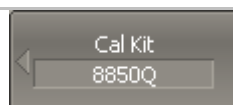

To save a calibration kit to file, click the following softkey:

**Save to File...**

### 5.3.1.6 Calibration Kit Loading from File

You can load the calibration kit files created by the previous command.

Move the highlighting to the required line in the calibration kit (See Figure 45).

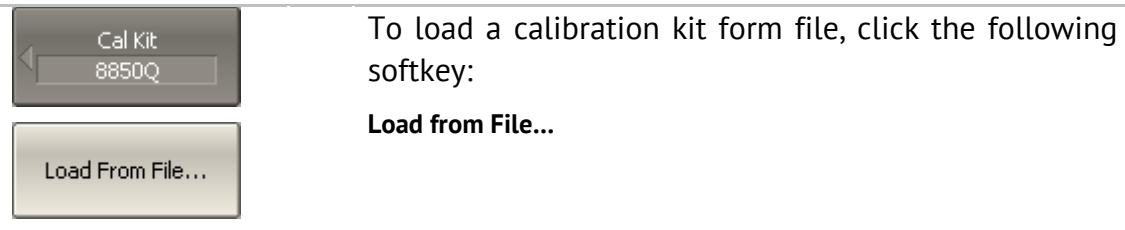

### 5.3.2 Calibration Standard Definition

The table of the calibration standards (See Figure 46) includes the full list of the standards in one calibration kit. For the standards defined by the model, the table contains the model parameters. For the data-based standards, the parameters of the model remain blank; S-parameters of such standards are represented in a different table (See section 5.3.3).

	Standard			Frequency		Offset		
	No	Type	Label	Min	Max	Delay	Z0	Loss
▶	1	Open	Open -M-	0 Hz	999 GHz	37.026 ps	50 Ω	700 MΩ/s
	2	Open	Open -F-	0 Hz	999 GHz	19.42 ps	50 Ω	700 MΩ/s
	3	Short	Short -M-	0 Hz	999 GHz	42.063 ps	50 Ω	700 MΩ/s
	4	Short	Short -F-	0 Hz	999 GHz	24.512 ps	50 Ω	700 MΩ/s
	5	Load	Broadband	0 Hz	999 GHz	0 s	50 Ω	0 Ω/s
	6	Thru/Delay	Thru	0 Hz	999 GHz	0 s	50 Ω	700 MΩ/s

Terminal Impedance	$C0 \cdot 10^{-15} F$	$C1 \cdot 10^{-27} F/Hz$	$C2 \cdot 10^{-36} F/Hz^2$	$C3 \cdot 10^{-45} F/Hz^3$
	$L0 \cdot 10^{-12} H$	$L1 \cdot 10^{-24} H/Hz$	$L2 \cdot 10^{-33} H/Hz^2$	$L3 \cdot 10^{-42} H/Hz^3$
	99.14	353.6	62.23	0
	103	0	110	10.2
	0	0	0	0
	0	0	0	0
50 Ω				

Figure 46 Calibration standard definition table

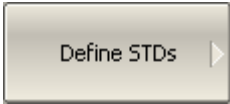
	<p>To open the table of calibration standard definitions, use the following softkeys:</p>
	<p><b>Calibration &gt; Cal Kit &gt; Define STDs</b></p>

### 5.3.2.1 Standard Adding to Calibration Kit

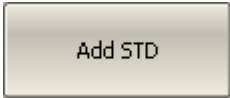
	<p>To add a calibration standard to the table of calibration standard definition (See Figure 46), use the following softkey:</p>
	<p><b>Add STD</b></p>

### 5.3.2.2 Standard Deleting from Calibration Kit

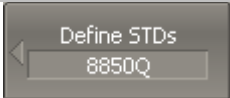
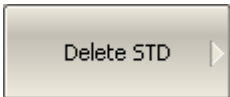
	<p>To delete a calibration standard from the table of calibration standard definition (See Figure 46), use the following softkey:</p>
	<p><b>Delete STD</b></p>

### 5.3.2.3 Calibration Standard Editing





Moving in the table of calibration standard definitions (See Figure 46) using navigation keys, enter the parameter values for a calibration kit:

<b>Standard No.</b>	The calibration standard number is specified in the calibration kit data sheet (just for information).
<b>Standard Type</b>	<p>Select the standard type:</p> <ul style="list-style-type: none"> <li>▪ <b>Open,</b></li> <li>▪ <b>Short,</b></li> <li>▪ <b>Load,</b></li> <li>▪ <b>Thru/Line,</b></li> <li>▪ <b>Unknown Thru (Planar 804/1 and S models only),</b></li> <li>▪ <b>Sliding Load,</b></li> <li>▪ <b>Data-Based</b></li> </ul>



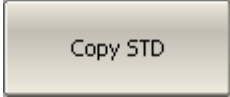

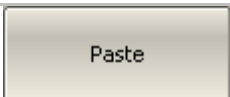
<b>Standard Label</b>	Standard labels specified on the calibration menu softkeys.
<b>Freq. Min.</b>	Lower cutoff frequency of the standard.
<b>Freq. Max.</b>	Upper cutoff frequency of the standard.
<b>Offset Delay</b>	Offset delay value in one direction (s).
<b>Offset Z0</b>	Offset wave impedance value ( $\Omega$ ).
<b>Offset Loss</b>	Offset loss value ( $\Omega/s$ ).
<b>Load Impedance</b>	Lumped load impedance value ( $\Omega$ ).
<b>C0 10<sup>-15</sup> F</b>	For an OPEN standard, C <sub>0</sub> coefficient in the polynomial formula of the fringe capacitance:  $C = C_0 + C_1 f + C_2 f^2 + C_3 f^3$
<b>C1 10<sup>-27</sup> F/Hz</b>	For an OPEN standard, C <sub>1</sub> coefficient in the polynomial formula of the fringe capacitance.
<b>C2 10<sup>-36</sup> F/Hz<sup>2</sup></b>	For an OPEN standard, C <sub>2</sub> coefficient in the polynomial formula of the fringe capacitance.
<b>C3 10<sup>-45</sup> F/Hz<sup>3</sup></b>	For an OPEN standard, C <sub>3</sub> coefficient in the polynomial formula of the fringe capacitance.
<b>L0 10<sup>-12</sup> H</b>	For a SHORT standard, L <sub>0</sub> coefficient in the polynomial formula of the residual inductance:  $L = L_0 + L_1 f + L_2 f^2 + L_3 f^3$
<b>L1 10<sup>-24</sup> H/Hz</b>	For a SHORT standard, L <sub>1</sub> coefficient in the polynomial formula of the residual inductance.
<b>L2 10<sup>-33</sup> H/Hz<sup>2</sup></b>	For a SHORT standard, L <sub>2</sub> coefficient in the polynomial formula of the residual inductance.
<b>L3 10<sup>-42</sup> H/Hz<sup>3</sup></b>	For a SHORT standard, L <sub>3</sub> coefficient in the polynomial formula of the residual inductance.

### 5.3.2.4 Calibration Standard Copy/Paste Function

	<p>To save a calibration standard into clipboard, highlight the required line in the calibration standard definition table (See Figure 46) and click the following softkey:</p>
	<p><b>Copy STD</b></p>
	<p>or</p>
	<p><b>Copy All STDs</b></p>
	<p>To paste the standard(s) from the clipboard, click the following softkey:</p>
	<p><b>Paste</b></p>

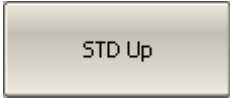
### 5.3.2.5 Management of Sequence in Standard Table

	<p>To change the sequence in the table, use the following softkeys:</p>
	<p><b>STD Up</b></p>
	<p>or</p>
	<p><b>STD Down</b></p>

### 5.3.3 Table of Calibration Standard S-Parameters

The table of calibration standard S-parameters (See Figure 47) allows viewing and editing of S-parameters of the calibration standards of the “Data-Based” type.

	Frequency	MLog(S11)	Arg(S11)	MLog(S21)	Arg(S21)
1	300 kHz	-67.5270094 dB	53.4023888 °	0.00394846762 dB	0.291495528 °
2	8.2997 MHz	-81.9584188 dB	-119.014476 °	0.00351271886 dB	0.322307311 °
3	16.2994 MHz	-78.8287269 dB	-128.601485 °	0.00322754052 dB	0.320729452 °
4	24.2991 MHz	-76.6945937 dB	-126.226624 °	0.00335760667 dB	0.321443452 °
5	32.2988 MHz	-75.3564463 dB	-123.320088 °	0.00336896915 dB	0.322652352 °
6	40.2985 MHz	-73.9037876 dB	-118.924822 °	0.00352190889 dB	0.325734959 °
7	48.2982 MHz	-72.3276906 dB	-114.247608 °	0.00416283402 dB	0.327349639 °
8	56.2979 MHz	-70.8755884 dB	-109.418739 °	0.00457673931 dB	0.322968328 °
9	64.2976 MHz	-69.1166427 dB	-105.957991 °	0.00452183965 dB	0.316878686 °

Figure 47 Table of calibration standard S-parameters

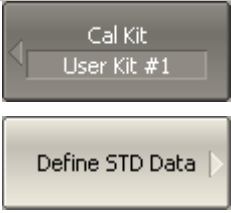

To open the table of calibration standard S-parameters, move the required line in the table (See Figure 47), and click the following softkeys:

**Define STD Data**

---

**Note** **Define STD Data** softkey is disabled if the type of the standard is other than “Data-Based”.



There are two different tables for one-port standards and for two-port standards. The table contains one parameter ( $S_{11}$ ) for one-port standards, and four parameters ( $S_{11}$ ,  $S_{21}$ ,  $S_{12}$ ,  $S_{22}$ ) for two-port standards. Before the user fills in the table, its type will be defined: by the Touchstone format (s1p or s2p) if the data is downloaded from a file, or the user will be requested to specify the type if the data is entered by the user.

The data in the table can be represented in three formats according to the user settings:

- Real part and Imaginary part,
- Linear magnitude and Phase (°),
- Logarithmic magnitude (dB) and Phase (°).

The following rule is applied for the calibration of a two-port standard: the standard is considered connected by Port 1 ( $S_{11}$ ) to the port with smallest number, and by Port 2 ( $S_{22}$ ) to the port with the biggest number. If you need to “reverse” a two-port standard, use the “Port Reverse” function (section 5.3.3.5).

### 5.3.3.1 Line Adding to Table

	<p>To add a line to the table of the calibration standard S-parameters (See Figure 47), use the following softkeys:</p>
	<p><b>Add Row</b></p>

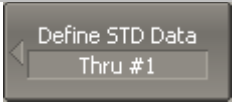
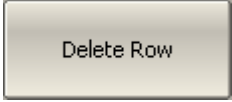

### 5.3.3.2 Line Deleting from Table

	<p>To delete a line from the table of the calibration standard S-parameters (See Figure 47), use the following softkey:</p>
	<p><b>Delete Line</b></p>

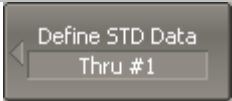
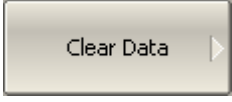
### 5.3.3.3 Table Clearing

	<p>To clear the entire table of the calibration standard S-parameters (See Figure 47), use the following softkey:</p>
	<p><b>Clear Data</b></p>

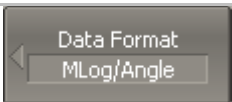
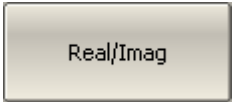
### 5.3.3.4 Table Format Selecting

	<p>To select the format of the table of the calibration standard S-parameters (See Figure 47), use the following softkey:</p>
	<p><b>Format &gt; Real/Imag   Magn/Angle   MLog/Angle</b></p>
	
	

### 5.3.3.5 Port Reversing

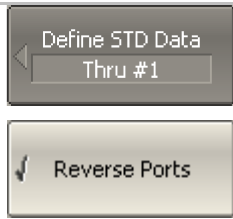

To enable/disable reversing of the ports of a two-port standard, use the following softkey:

**Reverse Ports**

### 5.3.3.6 Data Opening from File

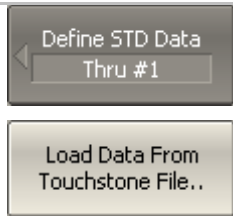

To open the data from Touchstone file, use the following softkey:

**Load Data from Touchstone file...**

In the pop-up dialog select the file type (s1p or s2p) and specify the file name.

### 5.3.4 Calibration Standard Class Assignment

The assignment of classes to the standards of the selected calibration kit is made in the table of standard classes (See Figure 48).

Standard labels filled in the table cells by selecting them from the list of calibration kit standards. Each row of the table corresponds to the standard class specified in the two left columns of the table.

If a single standard is assigned to the class then it filled into the "Subclass 1" column. If several standards are assigned to the class, as described in section 5.3.4, then "Subclass 2", "Subclass 3", etc. columns are filled in.

Class	Port	Subclass 1	Subclass 2	Subclass 3	S
Open	1	4. Open -M-			
	2	4. Open -M-			
Short	1	5. Short -M-			
	2	5. Short -M-			
Load	1	1. Lowdband	2. Sliding Load	3. Broadband	
	2	1. Lowdband	2. Sliding Load	3. Broadband	
Thru	1-2	11. Thru			
TRL Thru	1-2				
TRL Reflect	1				
	2				
TRL Line/Match	1-2				

Figure 48 Table of calibration standard classes

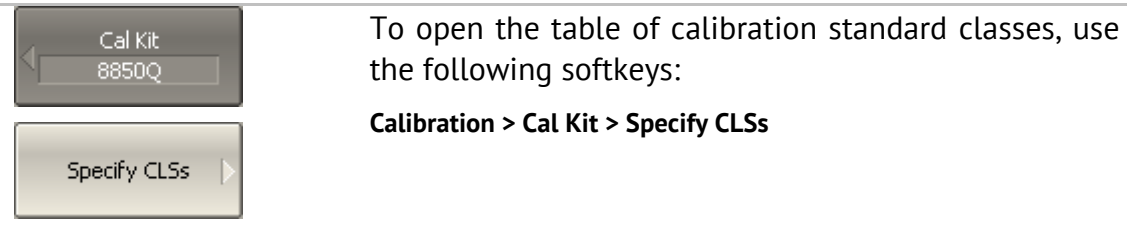

To open the table of calibration standard classes, use the following softkeys:

**Calibration > Cal Kit > Specify CLSs**

### 5.3.4.1 Standard Class Table Editing

Moving in the table of calibration standard classes (See Figure 48) using navigation keys, click «Enter» in the required cell for the pop-up menu. Select the standard label in the pop-up menu to assign it the class and port number specified in the left part of the table.

### 5.3.4.2 Standard Deleting from Standard Class Table

Moving in the table of calibration standard classes (See Figure 48) using navigation keys, click «Enter» in the required cell for the pop-up menu. Select the line **None** in the pop-up menu to delete the standard contained in the cell.

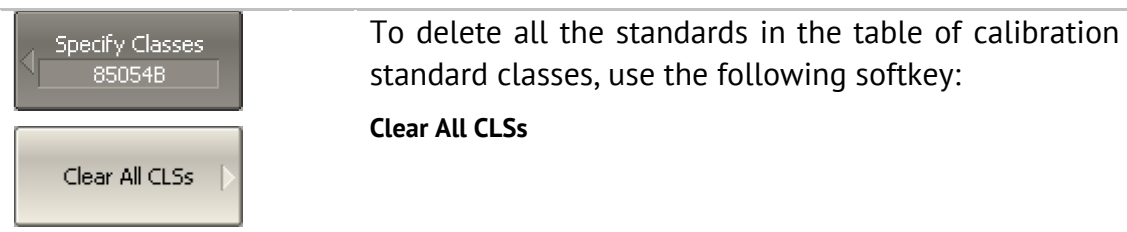

To delete all the standards in the table of calibration standard classes, use the following softkey:

**Clear All CLSs**

### 5.3.4.3 Strict Class Assignment Function

This function allows for limitation of the one standard type(s) available in each class by the feature of strict correspondence (See Table 21). If this function is disabled, any class can be assigned to the standard.

Table 21 Standard class and standard type correspondence

N	Standard Class	Standard Type
1	OPEN	<ul style="list-style-type: none"> <li>• Open,</li> <li>• Data-Based (One Port)</li> </ul>
2	SHORT	<ul style="list-style-type: none"> <li>• Short,</li> <li>• Data-Based (One Port)</li> </ul>
3	LOAD	<ul style="list-style-type: none"> <li>• Load,</li> <li>• Sliding Load,</li> </ul>

		<ul style="list-style-type: none"> <li>• Data-Based (One Port)</li> </ul>
4	THRU	<ul style="list-style-type: none"> <li>• Thru/Line,</li> <li>• Data-Based (Two Port)</li> </ul>
5	TRL THRU (Planar 804/1 and S models)	<ul style="list-style-type: none"> <li>• Thru/Line,</li> <li>• Data-Based (Two Port)</li> </ul>
6	TRL REFLECT (Planar 804/1 and S models)	<ul style="list-style-type: none"> <li>• Open,</li> <li>• Short,</li> <li>• Data-Based (One Port)</li> </ul>
7	TRL LINE/MATCH (Planar 804/1 and S models)	<ul style="list-style-type: none"> <li>• Load,</li> <li>• Thru/Line</li> </ul>

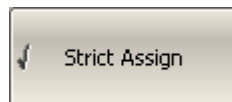
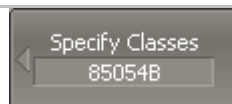

To disable/enable the function of strict class correspondence function, use the following softkey:

**Strict Assign**

#### 5.3.4.4 Function of Group Assignment of Port Number

This function allows for automatic assignment of one standard to all the ports of a specific class when assigned to at least one port.

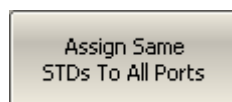
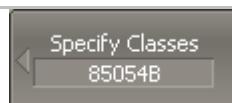

To enable/disable the function of group assignment of port number, use the following softkey:

**Assign Same STDs to All Ports**

## 5.4 Power Calibration

The Analyzer ensures steady power level at the test port inputs with the specified accuracy. The power level is defined by the user between the instrument's minimum and maximum output power level.

A DUT is connected to the Analyzer by cables, which have some losses. The power calibration allows the user to maintain a more accurate power level at a DUT input, adjusted to the use of the cables.

The power calibration is performed by an external power meter connected to the cables' ends, which will be later connected to the DUT. After the power calibration is complete, power correction automatically turns on. Later the user can disable or enable again the power correction function.

The power calibration is performed for each port and each channel individually.

---

Note	The power correction status is indicated in the trace status field (See section 4.2.2) and in the channel status bar (See section 4.2.6).
------	---

---

### 5.4.1 Loss Compensation Table

The loss compensation function allows the user to apply compensation for unwanted losses produced between the power meter and the calibrated port in the process of power calibration. Define the losses, which you need to compensate in the table (See Figure 49) specifying frequency and losses.

	Frequency	Loss
1	300 kHz	0.1 dB
2	1 GHz	0.2 dB
3	2 GHz	0.4 dB
4	3 GHz	0.5 dB
5		

Figure 49 Loss compensation table

Linear interpolation will be applied to the losses in the intermediary frequency points. The loss compensation table is defined for each port individually.

---



Note	To have the losses compensated for, you need to enable this function and fill out the table before you start the power calibration procedure.
------	---

---

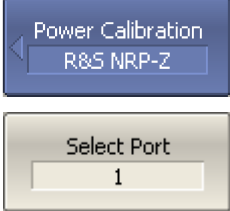

## 5.4.2 Power Calibration Procedure

Perform connection and setting of an external power meter as described in section 8.8. Connect the sensor to one of the test ports of the Analyzer and perform calibration as described below. Then repeat the calibration for the other test port.

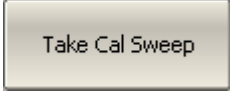
	<p>To select the calibrated port number, use the following softkeys:</p> <p><b>Calibration &gt; Power Calibration &gt; Select Port</b></p>
	<p>To zero power meter, use the following softkeys:</p> <p><b>Calibration &gt; Power Calibration &gt; Power Sensor Zero Correction</b></p>
<p>Note</p>	<p>Power meter sensor can be connected to the port, as during zero setting the output signal of the port is turned off.</p>
	<p>To execute power calibration, use the following softkeys:</p> <p><b>Calibration &gt; Power Calibration &gt; Take Cal Sweep</b></p>
<p>Note</p>	<p>After the power calibration is complete, power correction automatically turns on.</p>

## 5.4.3 Power Correction Setting

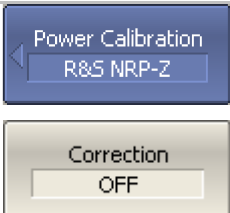
	<p>To enable/disable power correction, use the following softkeys:</p> <p><b>Calibration &gt; Power Calibration &gt; Correction</b></p>
---	---

## 5.4.4 Loss Compensation Table Editing

If you need to apply the loss compensation, enable this function and fill out the table before you start the power calibration procedure. Fill out the table for each port individually.

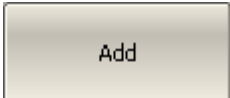
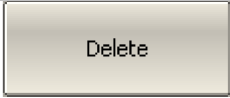
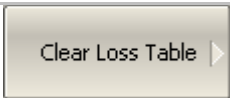
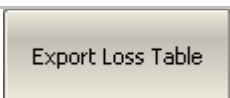
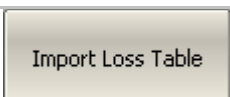
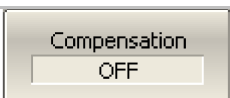
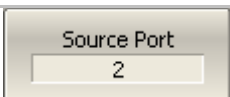
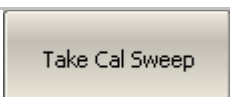
	<p>To add a new row to the loss compensation table, use the following softkeys:</p>
	<p><b>Calibration &gt; Power Calibration &gt; Loss Compen &gt; Add</b></p> <p>A new row will appear under the highlighted one.</p>
	<p>To delete a highlighted row, use the following softkeys:</p> <p><b>Calibration &gt; Power Calibration &gt; Loss Compen &gt; Delete</b></p>
	<p>To clear all the table, use the following softkeys:</p> <p><b>Calibration &gt; Power Calibration &gt; Loss Compen &gt; Clear Loss Table</b></p>
	<p>To save the table into a *.lct file on the hard, use the following softkeys:</p> <p><b>Calibration &gt; Power Calibration &gt; Loss Compen &gt; Export Loss Table</b></p>
	<p>To open the table from a *.lct file from the hard, use the following softkeys:</p> <p><b>Calibration &gt; Power Calibration &gt; Loss Compen &gt; Import Loss Table</b></p>
	<p>Enter frequency and loss values into the table, scrolling by navigation keys.</p>
	<p>To enable the loss compensation function, use the following softkeys:</p> <p><b>Calibration &gt; Power Calibration &gt; Loss Compen &gt; Compensation</b></p>
	<p>To select the source port number, use the following softkeys:</p> <p><b>Calibration &gt; Receiver Calibration &gt; Source Port</b></p>
	<p>To execute receiver calibration, use the following softkeys:</p> <p><b>Calibration &gt; Receiver Calibration &gt; Take Cal Sweep</b></p>
<p>Note</p>	<p>After the receiver calibration is complete, receiver correction automatically turns on.</p>

## 5.5 Receiver Calibration

When you perform absolute power measurements (See section 4.7.3), the gain of some receivers are factory calibrated to test port inputs.

In practice, the power is measured at test port inputs made by the fixture producing losses. The receiver calibration enables the user to measure the power at port inputs with higher accuracy.

The receiver calibration is performed by sending the calibration signal from the source port to the calibrated port input. The receiver calibration requires the connection between the both test ports using THRU line.

To make the receiver calibration most accurate, first perform power calibration on the source port. If the source power calibration was not performed, to get good results you need to connect the calibrated port to the source port on the front panel.

After the receiver calibration is complete, receiver correction automatically turns on. Later the user can disable or enable again the receiver correction function. Receiver calibration can be performed only for the test signal receivers (A and B) of each port (See Figure 20). Power calibration is performed for each port and each channel individually.

---

Note	The power correction status is indicated in the trace status field (See section 4.2.2) and in the channel status bar (See section 4.2.6).
------	---

---

### 5.5.1 Receiver Calibration Procedure

Connect a THRU line between the receiver port and the source port.



To select the calibrated port number, use the following softkeys:

**Calibration > Receiver Calibration > Select Port**

### 5.5.2 Receiver Correction Setting

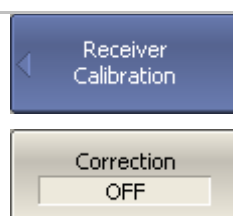

To enable/disable receiver correction, use the following softkeys:

**Calibration > Receiver Calibration > Correction**

## 5.6 Scalar Mixer Calibration

Scalar mixer calibration is the most accurate method of calibration applied to measurements of mixers in frequency offset mode.

The scalar mixer calibration requires OPEN, SHORT, and LOAD standards as well as external power meter (See Figure 50). The power meter connection and setup is described in section 8.8.

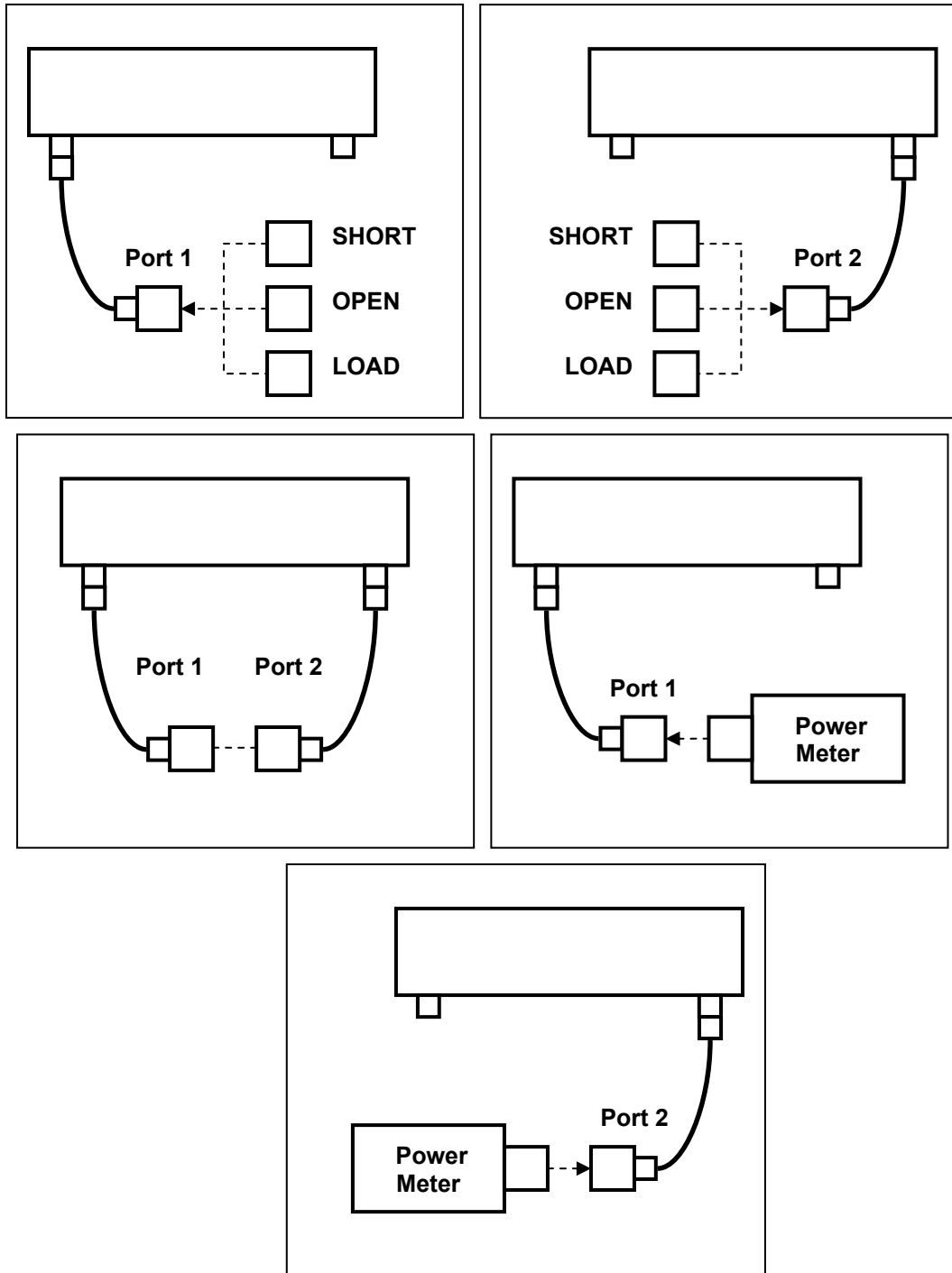

Figure 50 Scalar mixer calibration setup

The scalar mixer calibration allows the following measurements:

- reflection  $S_{11}$  and  $S_{22}$  parameters in vector form;
- transmission  $S_{21}$  and  $S_{12}$  parameters in scalar form.

Before you start the calibration, perform the following settings: select active channel and set its parameters (frequency span, IF bandwidth, etc.), and define the calibration kit. Then enable the frequency offset mode and perform the port settings.

---

Note

The scalar mixer calibration can be performed without frequency offset. You can enable the frequency offset mode later, during mixer measurements. In this case the basic frequency range should cover the frequency spans of the ports in offset mode. This procedure is convenient but less accurate as involves interpolation.

---



To access the scalar mixer calibration menu, use the following softkeys:

**Calibration > Mixer/Converter Calibration > Scalar Mixer Calibration**

---

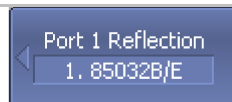

Click **Reflection Port 1** softkey.



Connect SHORT, OPEN and LOAD standards to Port 1 as shown in Figure 50. Perform two measurements over two frequency ranges (**Freq 1** and **Freq 2**) for each standard using the respective standard softkeys.



If the frequency offset is disabled, after measurement over one frequency range the result will be automatically saved for the both frequency ranges.



The instrument status bar will indicate **Calibration in progress...** when the measurement is in progress. On completion of the measurement, a check mark will appear in the left part of the softkey.



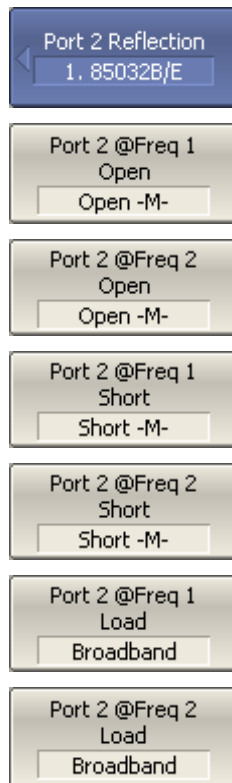

Click **Reflection Port 2** softkey.

Connect SHORT, OPEN and LOAD standards to Port 2 as shown in Figure 50. Perform two measurements over two frequency ranges (**Freq 1** and **Freq 2**) for each standard using the respective standard softkeys.

If the frequency offset is disabled, after measurement over one frequency range the result will be automatically saved for the both frequency ranges.

The instrument status bar will indicate **Calibration in progress...** when the measurement is in progress. On completion of the measurement, a check mark will appear in the left part of the softkey.

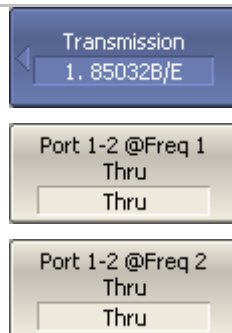

Click **Transmission** softkey.

Connect a THRU standards between the test ports. If the port connectors allow, connect the ports directly together (through line with zero electrical length). Perform two measurements over two frequency ranges (**Freq 1** and **Freq 2**).

If the frequency offset is disabled, after measurement over one frequency range the result will be automatically saved for the both frequency ranges.

The instrument status bar will indicate **Calibration in progress...** when the measurement is in progress. On completion of the measurement, a check mark will appear in the left part of the softkey.

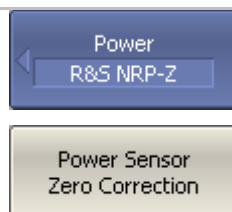

Click **Power** softkey.

To zero power meter, click **Power Sensor Zero Correction** softkey.

#### Note

Power meter sensor can be connected to the port, as during zero setting the output signal of the port is turned off.

Port 1 @Freq 1	Connect the power meter to Port 1. Perform two measurements over two frequency ranges ( <b>Freq 1</b> and <b>Freq 2</b> ).
Port 1 @Freq 2	If the frequency offset is disabled, after measurement over one frequency range the result will be automatically saved for the both frequency ranges.
Port 2 @Freq 1	Connect the power meter to Port 2. Perform two measurements over two frequency ranges ( <b>Freq 1</b> and <b>Freq 2</b> ).
Port 2 @Freq 2	The instrument status bar will indicate <b>Calibration in progress...</b> when the measurement is in progress. On completion of the measurement, a check mark will appear in the left part of the softkey.
Apply	To complete the calibration procedure, click <b>Apply</b> .  This will activate the process of calibration coefficient table calculation and saving it into the memory. The error correction function will also be automatically enabled.
Cancel	To clear the measurement results of the standards, click <b>Cancel</b> .  This softkey does not cancel the current calibration. To disable the current calibration turn off the error correction function.
Note	You can check the calibration status in channel status bar (See table 5.5) or in trace status field (See Table 20) – <b>SMC</b> label.

## 5.7 Vector Mixer Calibration

Vector scalar calibration is a calibration method applied for mixer measurements. This method allows measurement of both reflection and transmission S-parameters in vector form, including phase and group delay of transmission coefficient.

The vector mixer measurements require an additional mixer with filter, which is called calibration mixer.

The filter separates the IF, which is the input frequency for the mixer under test:

- $RF + LO$
- $RF - LO$
- $LO - RF$

Both calibration mixer and mixer under test are powered from one LO.

The vector mixer measurement is a combination of a 2-port calibration and a de-embedding function (See Figure 51).

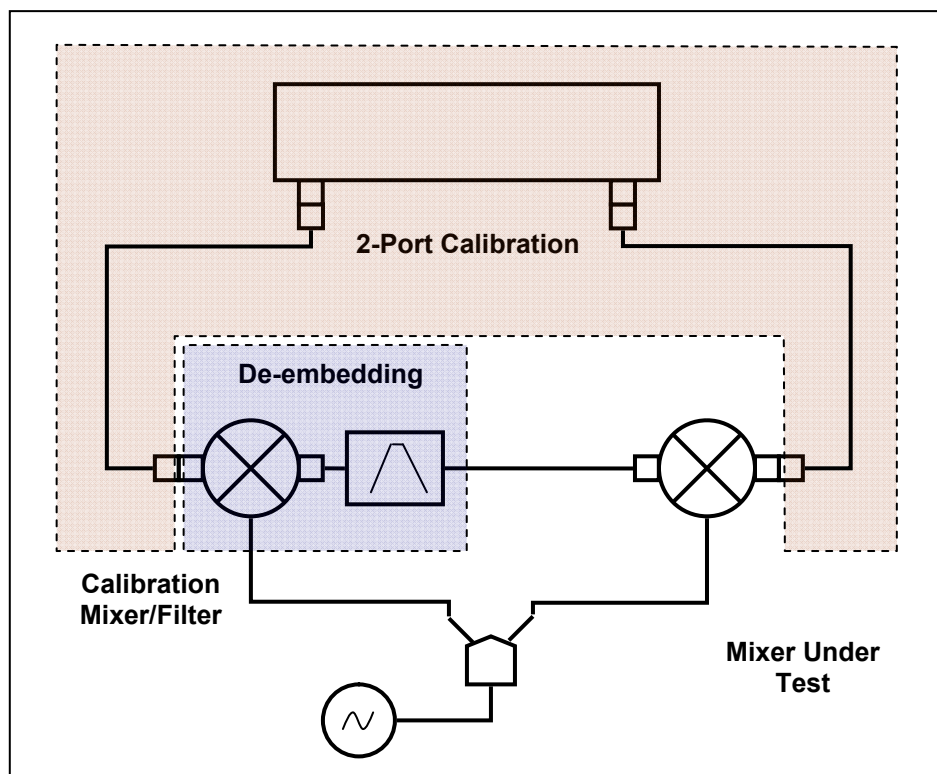

Figure 51 Vector mixer measurements



The de-embedding function requires an S-parameter file of the circuit. Acquisition of such a file for the calibration mixer/filter pair is called vector mixer calibration.

To obtain an S-parameter file of the calibration mixer/filter, you need to use SHORT, OPEN, and LOAD calibration standards (See Figure 52).

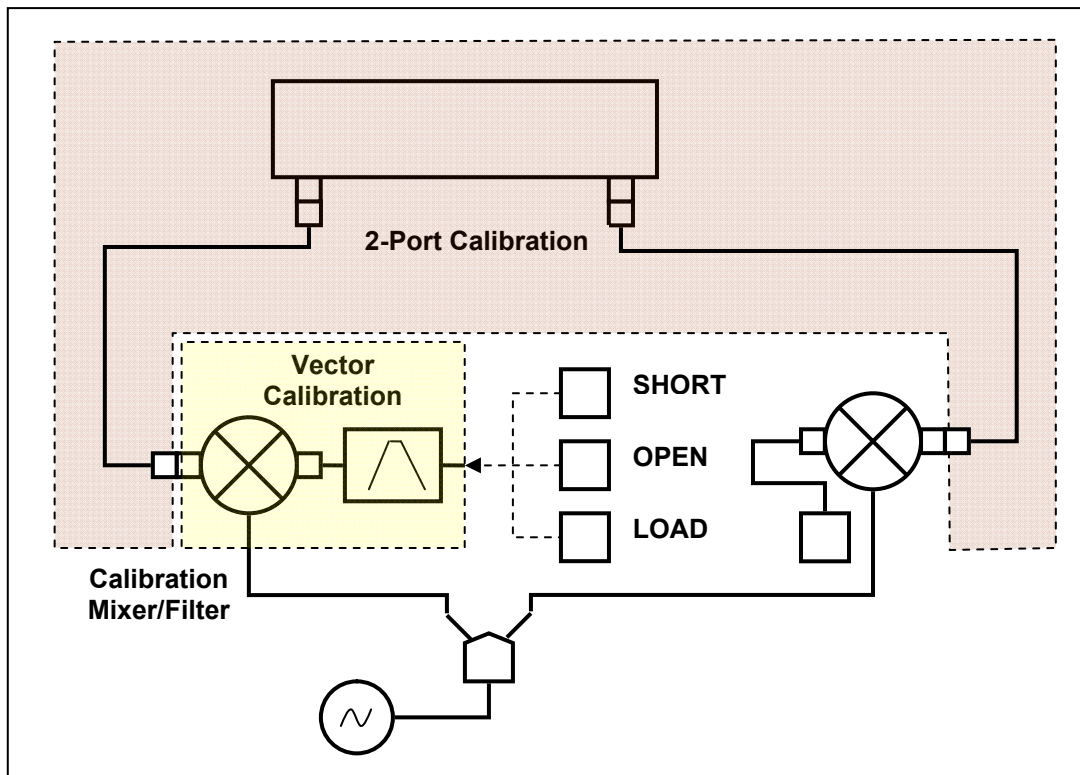

Figure 52 Vector Mixer Calibration

### 5.7.1 Vector Mixer Calibration Procedure

Before you start the calibration, perform the following settings: activate a channel and set its parameters (frequency span, IF bandwidth, etc.), and define the calibration kit.

- Perform 2-port calibration.
- Assemble vector calibration setup.
- Set frequency and power of the external LO.



To access the vector mixer calibration menu, use the following softkeys:

**Calibration > Mixer/Converter Calibration > Vector Mixer Calibration**

	<p>To select the number of test port connected to the calibration mixer, click <b>Select Port</b>.</p>
	<p>Enter the LO frequency, using <b>LO Frequency</b> softkey.</p>
	<p>Select the frequency to be separated by the filter, using <b>IF Frequency</b> softkey:</p> <ul style="list-style-type: none"> <li>▪ <b>RF + LO</b></li> <li>▪ <b>RF - LO</b></li> <li>▪ <b>LO - RF</b></li> </ul>
	<p>Connect SHORT, OPEN and LOAD standards to IF filter output as shown in Figure 52. Perform the measurement using the respective standard softkey.</p> <p>The instrument status bar will indicate <b>Calibration in progress...</b> when the measurement is in progress. On completion of the measurement, a check mark will appear in the left part of the softkey.</p>
	<p>To complete the calibration procedure, click <b>Save To Touchstone File</b>.</p>
	<p>This will activate calculation of the calibration mixer/filter pair S-parameters, and saving those into a Touchstone file. Enter the file name in the pop-up dialog.</p> <p>If <b>Setup Option</b> feature is enabled, S-parameter file will be passed to the de-embedding function and this function will be activated.</p>
<p>Note</p>	<p>You can check the calibration status in channel status bar (See Table 19) – <b>F2</b> and <b>Dmb</b> labels (2-port calibration and de-embedding function).</p>

## 5.8 Automatic Calibration Module

Automatic calibration module (ACM) is a special device, which allows for automating of the process of calibration. ACM is shown in Figure 53.



Figure 53 Automatic Calibration Module

ACM offers the following advantages over the traditional SOLT calibration, which uses a mechanical calibration kit:

- Reduces the number of connections of standards. Instead of connecting seven standards, it requires connecting only two ACM connectors;
- Reduces the calibration time;
- Reduces human error probability;
- Provides higher accuracy potentially.

ACM has two RF connectors for connection to the Analyzer test ports and a USB connector for control. ACM contains electronic switches, which switch between different reflection and transmission impedance states, as well as memory, which stores precise S-parameters of these impedance states.

After you connect the ACM to the Analyzer, the Analyzer software performs the calibration procedure automatically, i.e. switches between different ACM states, measures them, and computes calibration coefficients using the data stored in the ACM memory.

## 5.8.1 Automatic Calibration Module Features

### **Calibration Types:**

ACM allows the Analyzer software to perform full two-port or full one-port calibrations with the click of a button. We recommend that you terminate the unusable ACM port with a load while performing one-port calibration.

### **Characterization:**

Characterization is a table of S-parameters of all the states of the ACM switches, stored in the ACM memory. There are two types of characterization: user characterization and factory characterization. ACM has two memory sections. The first one is write-protected and contains factory characterization. The second memory section allows you to store up to three user characterizations. Before calibration you can select the factory characterization or any of the user characterizations stored in the ACM memory. The user characterization option is provided for saving new S-parameters of the ACM after connecting adapters to the ACM ports.

The software enables you to perform a user characterization and save the data to ACM with the click of a button. To be able to do this, you should first calibrate the Analyzer test ports in configuration compatible with the ACM ports.

### **Automatic Orientation:**

Orientation means relating the ACM ports to the test ports of the Analyzer. While the Analyzer test ports are indicated by numbers, the ACM ports are indicated by letters A and B.

Orientation is defined either manually by the user, or automatically. The user is to select the manual or automatic orientation method. In case of automatic orientation, the Analyzer software determines the ACM orientation each time prior to its calibration or characterization.

### **Unknown Thru (Planar 804/1 and S models):**

The Thru implemented by the electronic switches inside the ACM introduces losses. That is why you should know the exact parameters of the Thru or use an Unknown Thru algorithm to achieve the specified calibration accuracy.

The software allows using the both options. ACM memory stores S-parameters of the Thru, which are used to compute calibration coefficients. In case if an Unknown Thru algorithm is applied, such parameters are disregarded.

### Thermal Compensation:

The most accurate calibration can be achieved if the ACM temperature is equal to the temperature, at which it was characterized. When this temperature changes, certain ACM state parameters may deviate from the parameters stored in the memory. This results in reduction of the ACM calibration accuracy.

To compensate for the thermal error, the ACM features thermal compensation function. Thermal compensation is a software function of the ACM S-parameter correction based on its temperature dependence and the data from the temperature sensor inside the ACM. The temperature dependence of each ACM is determined at the factory and saved into its memory.

The function of thermal compensation can be enabled or disabled by the user.

### Confidence Check:

ACM also implements an additional state – an attenuator, which is not used in calibration. The attenuator is used to check the current calibration performed by ACM or any other method. Such test is called a confidence check.

The confidence check consists in simultaneous display of the measured and stored in memory S-parameters of the attenuator. The measured parameters are shown as the data trace and the parameters saved in the ACM memory are shown as the memory trace. You can compare the two traces, evaluate their differences and determine the accuracy of the calibration performed.

For a detailed comparison you can use the math (division) function for data and memory.

## 5.8.2 Automatic Calibration Procedure

Before calibrating the Analyzer with ACM, perform some settings, i.e. activate a channel and set channel parameters (frequency range, IF bandwidth, etc.).

Connect the ACM to the Analyzer test ports, and connect the USB port of the ACM to the USB port of the computer.

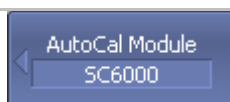



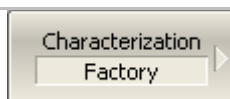

To start automatic calibration, use the following softkeys:

**Calibration > AutoCal**

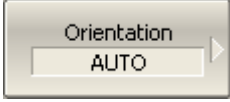

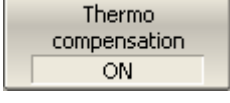
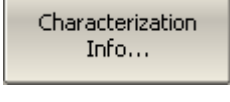
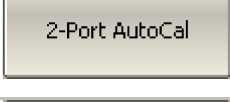
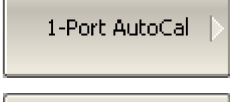
Select characterization using **Characterization** softkey.

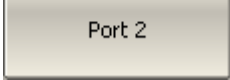
	<p>Select manual or automatic orientation of the ACM using <b>Orientation</b> softkey.</p>
	<p>(Planar 804/1 and S models): Enable or disable Unknown Thru algorithm using <b>Unkn. Thru</b> softkey.</p>
	<p>Enable or disable the thermal compensation using <b>Thermal Compensation</b> softkey.</p>
	<p>To display detailed information on characterization, use <b>Characterization Info</b> softkey.</p>
	<p>To perform full two-port calibration, use <b>2-Port AutoCal</b> softkey.</p>
	<p>To perform full one-port calibration, use <b>1-Port AutoCal</b> softkey.</p>
	<p>Then select the port number.</p>
	

### 5.8.3 User Characterization Procedure

User characterization of ACM is required in case of ACM connectors modification by the use of adapters. The characterization is performed for the new ACM configuration, which includes adapters. To ensure calibration accuracy it is not recommended to disconnect and reconnect the adapters back.

Before you perform the user characterization of the ACM, perform full two-port calibration of the Analyzer in configuration of the test ports compatible with the configuration of ACM ports.

Connect the ACM to the Analyzer test ports, and connect the USB port of the ACM to the USB port of the computer.

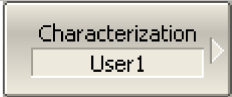
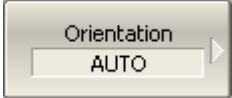
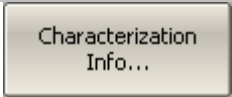
	Select user characterization 1 to 3 using <b>Characterization</b> softkey.
	Select manual or automatic orientation of the ACM using <b>Orientation</b> softkey.  It is recommended to select <b>AUTO</b> orientation.
	Perform characterization using <b>Characterize ACM</b> softkey.

After the ACM measurement is completed, the following dialog box will appear:

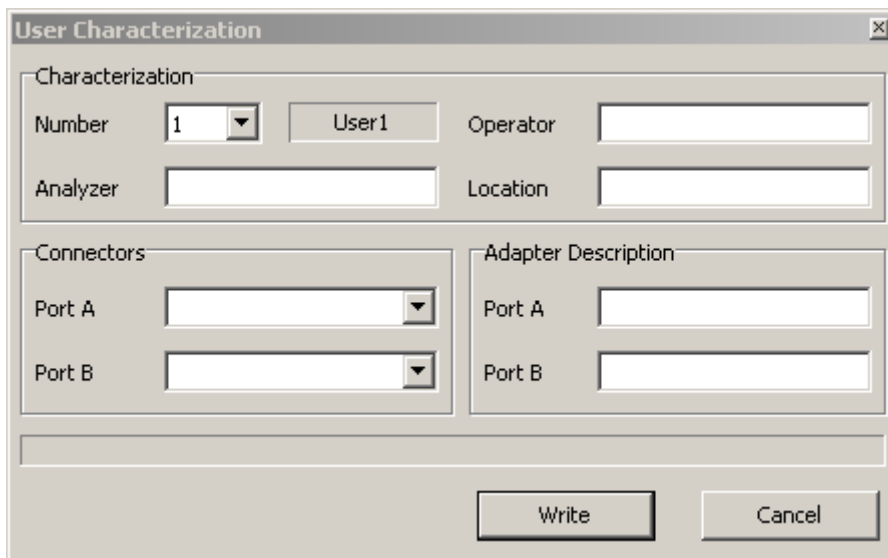

The dialog box titled "User Characterization" contains the following fields:

- Characterization** section:
  - Number: dropdown menu with "1" selected.
  - User: text field containing "User1".
  - Operator: empty text field.
  - Analyzer: empty text field.
  - Location: empty text field.
- Connectors** section:
  - Port A: dropdown menu.
  - Port B: dropdown menu.
- Adapter Description** section:
  - Port A: empty text field.
  - Port B: empty text field.

At the bottom of the dialog are "Write" and "Cancel" buttons.

Fill in the following fields:

- User name;
- Analyzer name;
- Characterization location;
- Connectors (types of adapter connectors);
- Adapter description (description of adapters).



Use **Save** softkey to complete the user characterization of the ACM.

## 5.8.4 Confidence Check Procedure

In case you need to verify the reliability of the current calibration, perform the confidence check. This function can be used to check the accuracy of either calibration performed with an ACM or with a mechanical calibration kit.

Connect the ACM to the Analyzer test ports, and connect the USB port of the ACM to the USB port of the computer.

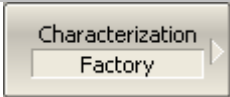
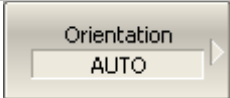
Enable the display of the data trace for the needed parameter, for example S21. It is possible to enable several data traces simultaneously, for example, S11, S22, S21, S12.

	Select characterization using <b>Characterization</b> softkey.
	Select manual or automatic orientation of the ACM using <b>Orientation</b> softkey.  It is recommended to select <b>AUTO</b> orientation.
	Perform confidence check using <b>Confidence Check</b> softkey.

After the measurement is completed, two traces for each S-parameter will be displayed. The measured parameters will be shown as the data trace, and the ACM parameters will be shown as the memory trace.

Compare the data trace and the memory trace of the same parameter, for example S21. To perform more accurate comparison, enable the function of math operations between data and memory traces. In the logarithmic magnitude or phase format use the Data / Memory operation. In the linear magnitude format use the Data – Memory operation.

The conclusion on whether the current calibration provides sufficient accuracy or not is made by the user.



## 6 MEASUREMENT DATA ANALYSIS

### 6.1 Markers

A marker is a tool for numerical readout of a stimulus value and value of the measured parameter in a specific point on the trace. You can activate up to 16 markers on each trace. See a trace with two markers in Figure 54.

The markers allow the user to perform the following tasks:

- Reading absolute values of a stimulus and a measured parameter in selected points on the trace;
- Reading relative values of a stimulus and a measured parameter related to the reference point;
- Search for specific points on the trace (minimum, maximum, target level, etc.);
- Determining trace parameters (statistics, bandwidth, etc.);
- Editing stimulus parameters using markers.

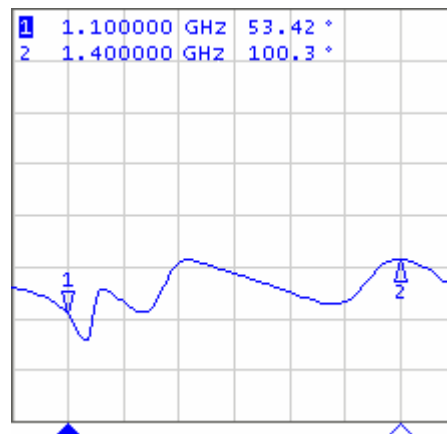

Figure 54

Markers can have the following indicators:

1 ▽	symbol and number of the active marker on a trace,
△ 2	symbol and number of the inactive marker on a trace,
▲	symbol of the active marker on a stimulus axis,
△	symbol of the inactive marker on a stimulus axis.

The marker data field contains the marker number, stimulus value, and the measured parameter value. The number of the active marker is highlighted in inverse color.

The marker data field contents vary depending on the display format (rectangular or circular).

- In rectangular format, the marker shows the measurement parameter value plotted along Y-axis in the active format (See Table 8).
- In circular format, the marker shows two or three values listed in Table 22

Table 22 Marker readings in circular formats

Label	Marker Readings (Measurement Unit)		
	Reading 1	Reading 2	Reading 3
<b>Smith (Lin)</b>	Linear magnitude	Phase (°)	-
<b>Smith (Log)</b>	Logarithmic magnitude (dB)	Phase (°)	-
<b>Smith (Re/Im)</b>	Real part	Imaginary part	-
<b>Smith (R + jX)</b>	Resistance ( $\Omega$ )	Reactance ( $\Omega$ )	Equivalent capacitance or inductance (F/H)
<b>Smith (G + jB)</b>	Conductance (S)	Susceptance (S)	Equivalent capacitance or inductance (F/H)
<b>Polar (Lin)</b>	Linear magnitude	Phase (°)	-
<b>Polar (Log)</b>	Logarithmic magnitude (dB)	Phase (°)	-
<b>Polar (Re/Im)</b>	Real part	Imaginary part	-

### 6.1.1 Marker Adding



To enable a new marker, use the following softkeys:

**Markers > Add Marker**



Note

The new marker appears as the active marker in the middle of the stimulus axis. The marker stimulus value entry field activates.

### 6.1.2 Marker Deleting



To delete a marker, use the following softkeys:

**Markers > Delete Marker**

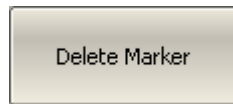

To delete all the markers, use the following softkeys:

**Markers > Delete All Markers**

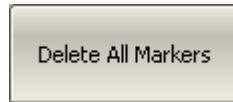

### 6.1.3 Marker Stimulus Value Setting

Before you set the marker stimulus value, you need to select the active marker. You can set the stimulus value by entering the numerical value from the keyboard, by arrows, or by dragging the marker using the mouse, or enabling the search function. Drag-and-drop operation is described in section 4.3.12. Marker search function is described in section 6.1.7.



To set the marker stimulus value, use the following softkeys:

**Markers > Edit Stimulus**

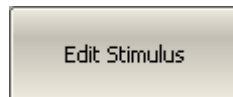

or make a mouse click on the stimulus value field.

Then enter the value using the numerical keys on the keypad, by «↑», «↓» arrows.

### 6.1.4 Marker Activating

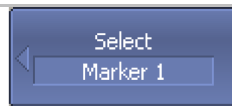

To activate a marker by its number, use the following softkeys:



**Markers > Select > Marker n**

...



To activate a marker from the list of markers, use the following softkeys:

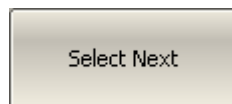

**Markers > Select Next**

Note

You can activate a marker by making a mouse click on it.

### 6.1.5 Reference Marker Feature

Reference marker feature allows the user to view the data relative to the reference marker. Other marker readings are represented as delta relative to the reference marker. The reference marker shows the absolute data. The reference marker is indicated with  $\Delta$  symbol instead of a number (See Figure 55). Enabling of a reference marker turns all the other markers to relative display mode.

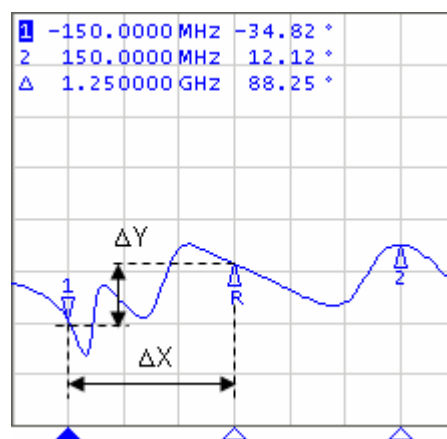



Figure 55

Reference marker can be indicated on the trace as follows:

R ▽	symbol of the active reference marker on a trace;
△ R	symbol of the inactive reference marker on a trace.

The reference marker displays the stimulus and measurement absolute values. All the rest of the markers display the relative values:

- stimulus value – difference between the absolute stimulus values of this marker and the reference marker;
- measured value – difference between the absolute measurement values of this marker and the reference marker.

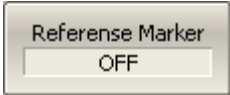
	To enable/disable the reference marker, use the following softkeys:
	<b>Markers &gt; Reference Marker</b>

## 6.1.6 Marker Properties

### 6.1.6.1 Marker Coupling Feature

The marker coupling feature enables/disables dependence of the markers of the same numbers on different traces. If the feature is turned on, the coupled markers (markers with same numbers) will move along X-axis synchronously on all the traces. If the coupling feature is off, the position of the markers with same numbers along X-axis will be independent (See Figure 56).

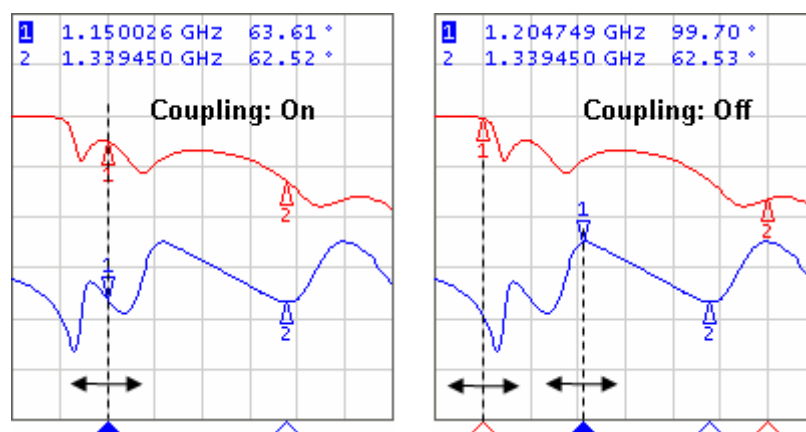

Figure 56 Marker coupling feature

< Marker Properties

To enable/disable the marker coupling feature, use the following softkeys:

✓ Marker Couple

**Markers > Properties > Marker Couple**

### 6.1.6.2 Marker Table

The marker table enables you to view the values of the markers of all the traces and all the channels (See Figure 57).

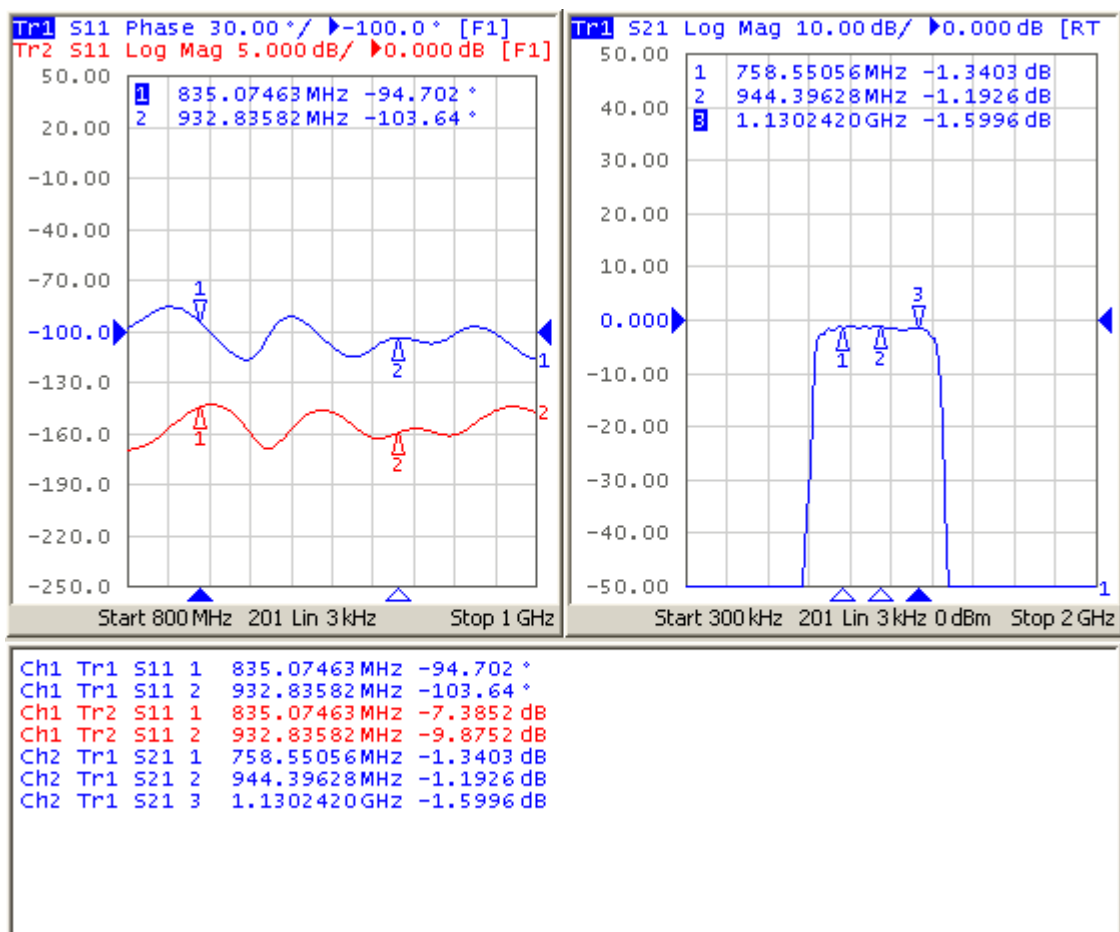

Figure 57 Marker table

< Marker Properties

To show/hide the marker table, use the following softkeys:

✓ Marker Table

**Markers > Properties > Marker Table**

### 6.1.6.3 Marker Value Indication Capacity

By default, the marker stimulus values are displayed with 8 decimal digits and marker response values are displayed with 5 decimal digits. The user can change these settings.

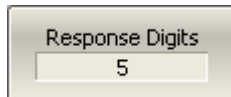
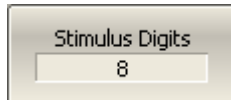

To set the marker value indication capacity, use the following softkeys:

**Markers > Properties > Stimulus Digits**

**Markers > Properties > Response Digits**

### 6.1.6.4 Multi Marker Data Display

If several overlapping traces are displayed in one graph, by default only active marker data are displayed on the screen. The user can enable display of the marker data of all the traces simultaneously. The markers of different traces will be distinguished by the color. Each marker will have same color with its trace.

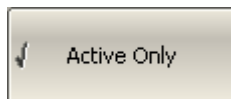

To enable/disable the multi marker data display, toggle the softkey:

**Markers > Marker Properties > Active Only**

Note

When multi marker data display is enabled, to avoid data overlapping on the screen, arrange the marker data on the screen (See section 6.1.6.5).

### 6.1.6.5 Marker Data Arranging

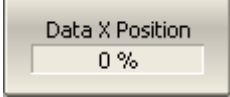
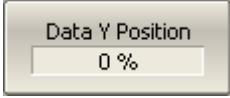

By default, the marker data are displayed in the upper left corner of the screen. The user can rearrange the marker data display on the screen. The marker data position on the screen is described by two parameters: relative position on the X and Y axes, in percent. Zero percent is upper left corner, 100% is lower right corner. Marker data position for each trace is set separately. This allows the user to avoid data overlapping on the screen.

	<p>To arrange the marker data on the screen, enter the relative position on the X and Y axes, using the following softkeys:</p>
	<p><b>Markers &gt; Marker Properties &gt; Data X Position</b></p>
	<p><b>Markers &gt; Marker Properties &gt; Data Y Position</b></p>
<p>Note</p>	<p>You can also drag-and-drop the marker data by the mouse.</p>

### 6.1.6.6 Marker Data Alignment

By default, the marker data are displayed independently for each trace. The user can align the marker data display on the screen. The alignment deactivates the independent marker data layout. In this case, the relative position on the X and Y axes is valid only for the first trace. The marker data of the other traces become aligned relatively to the first trace. Two types of alignment are available:

- Vertical – marker data of different traces are displayed one under another;
- Horizontal – marker data of different traces are displayed in line.

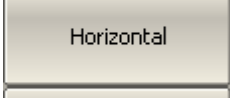
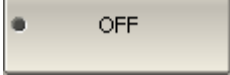
	<p>To set the marker data alignment, use the following softkeys:</p>
	<p><b>Markers &gt; Marker Properties &gt; Align &gt;</b></p>
	<p><b>Vertical   Horizontal   OFF</b></p>
	

### 6.1.6.7 Memory Trace Value Display

By default, the marker values of the data traces (not memory traces) are displayed on the screen. The user can enable the display of memory trace maker values, if a memory trace is available.

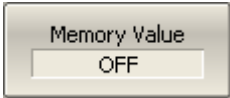

	<p>To enable/disable the display of memory trace marker values, toggle the softkey:</p>
	<p><b>Marker &gt; Marker Properties &gt; Memory Value</b></p>

## 6.1.7 Marker Position Search Functions

Marker position search function enables you to find on a trace the following values:

- maximum value;
- minimum value;
- peak value;
- target level.

### 6.1.7.1 Search for Maximum and Minimum

Maximum and minimum search functions enable you to determine the maximum and minimum values of the measured parameter and move the marker to these positions on the trace (See Figure 58).

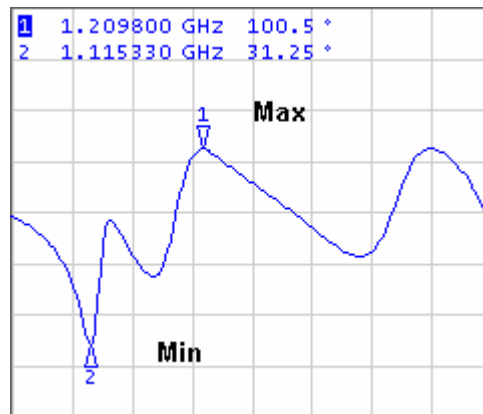

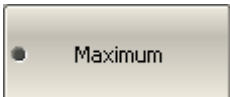



Figure 58 Maximum and minimum search

	<p>To find the maximum or minimum values on a trace, use the following softkeys:</p>
	<p><b>Markers &gt; Marker Search &gt; Maximum</b></p>
	<p><b>Markers &gt; Marker Search &gt; Minimum</b></p>

Note Before you start maximum or minimum search, first activate the marker.

In Smith chart and polar formats the search is executed for the first value of the marker.

### 6.1.7.2 Search for Peak

Peak search function enables you to determine the peak value of the measured parameter and move the marker to this position on the trace (See Figure 59).

**Peak** is a local extreme of the trace.

Peak is called **positive** if the value in the peak is greater than the values of the adjacent points.

Peak is called **negative** if the value in the peak is smaller than the values of the adjacent points.

**Peak excursion** is the smallest of the absolute differences between the response values in the peak point and the two adjoining peaks of the opposite polarity.

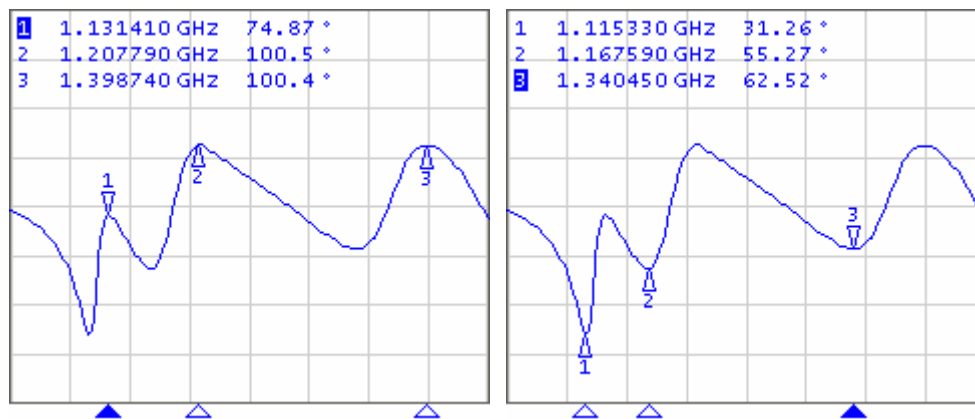

Figure 59 Positive and negative peaks

The peak search is executed only for the peaks meeting the following conditions:

- The peaks must have the polarity (positive, negative, or both) specified by the user;
- The peaks must have the peak deviation not less than the value assigned by the user.

The following options of the peak search are available:

- Search for nearest peak;

- Search for greatest peak;
- Search for left peak;
- Search for right peak.

The nearest peak is a peak, which is located most near to the current position of the marker along the stimulus axis.

The greatest peak is a peak with maximum or minimum value, depending on the current polarity settings of the peak.

---

Note	The search for the greatest peak is deferent from the search for maximum or minimum as the peak cannot be located in the limiting points of the trace even if these points have maximum or minimum values.
------	--

---

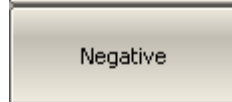
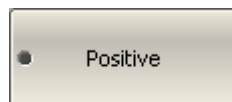
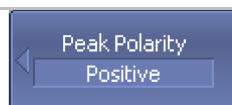

To set the polarity of the peak, use the following softkeys:

**Markers > Marker Search > Peak > Peak Polarity > Positive | Negative | Both**

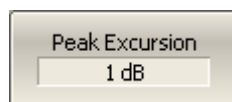

To enter the peak excursion value, use the following softkeys:

**Markers > Marker Search > Peak > Peak Excursion**

Then enter the value using numerical keypad, or «↑», «↓» arrows.

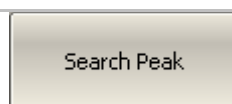

To activate the nearest peak search, use the following softkeys:

**Markers > Marker Search > Peak > Search Peak**

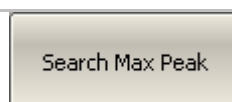

To activate the greatest peak search, use the following softkeys:

**Markers > Marker Search > Peak > Search Max Peak**

---

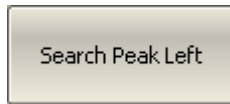

To activate the left peak search, use the following softkeys:

**Markers > Marker Search > Peak > Search Peak Left**



To activate the right peak search, use the following softkeys:

**Markers > Marker Search > Peak > Search Peak Right**

#### Note

Before you start maximum or minimum search, first activate the marker.

In Smith chart and polar formats the search is executed for the first value of the marker.

### 6.1.7.3 Search for Target Level

Target level search function enables you to locate the marker with the given level of the measured parameter (See Figure 60).

The trace can have two types of transition in the points where the target level crosses the trace:

- transition type is positive if the function derivative (trace slope) is positive at the intersection point with the target level;
- transition type is negative if the function derivative (trace slope) is negative at the intersection point with the target level.

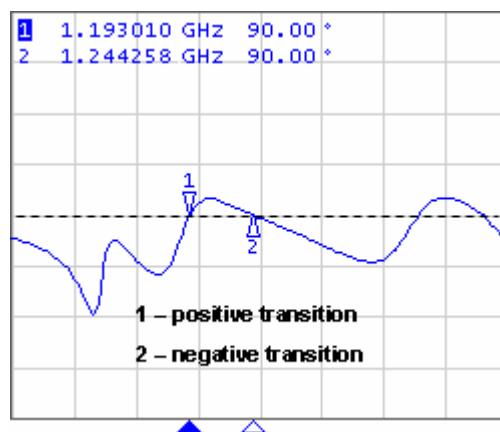

Figure 60 Target level search

The target level search is executed only for the intersection points, which have the specific transition polarity selected by the user (positive, negative, or both).

The following options of the target level search are available:

- Search for nearest target;
- Search for left target;
- Search for right target.

 <p>The screenshot shows a menu titled 'Target Transition' with three options: 'Both', 'Positive', and 'Negative'. The 'Both' option is selected, indicated by a small black dot to its left.</p>	<p>To set the transition polarity, use the following softkeys:</p> <p><b>Markers &gt; Marker Search &gt; Target &gt; Target Transition &gt; Positive   Negative   Both</b></p>
 <p>The screenshot shows a menu titled 'Search Target' with one option: 'Marker 1'. The 'Marker 1' option is selected, indicated by a small black dot to its left.</p>	<p>To enter the target level value, use the following softkeys:</p> <p><b>Markers &gt; Marker Search &gt; Target &gt; Target Value</b></p> <p>Then enter the value using numerical keypad, or «↑», «↓» arrows.</p>
 <p>The screenshot shows a menu titled 'Search Target' with one option: 'Search Target'. The 'Search Target' option is selected, indicated by a small black dot to its left.</p>	<p>To activate the nearest target search, use the following softkeys:</p> <p><b>Markers &gt; Marker Search &gt; Target &gt; Search Target</b></p>
 <p>The screenshot shows a menu titled 'Search Target Left' with one option: 'Search Target Left'.</p>	<p>To activate the left target search, use the following softkeys:</p> <p><b>Markers &gt; Marker Search &gt; Target &gt; Search Target Left</b></p>
 <p>The screenshot shows a menu titled 'Search Target Right' with one option: 'Search Target Right'.</p>	<p>To activate the right target search, use the following softkeys:</p> <p><b>Markers &gt; Marker Search &gt; Target &gt; Search Target Right</b></p>

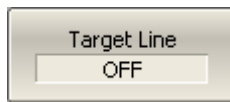

To enable/disable target level indication on the screen, use the following softkeys:

**Markers > Marker Search > Target > Target Line**



**Clear All Target Lines** softkey disables indication of target level lines of all the markers.

---

#### Note

Before you start maximum or minimum search, first activate the marker.

In Smith chart and polar formats the search is executed for the first value of the marker.

---

### 6.1.7.4 Search Tracking

The marker position search function by default can be initiated by any search key pressing. Search tracking mode allows you to perform continuous marker position search, until this mode is disabled.



To enable/disable search tracking mode, use the following softkeys:

**Markers > Marker Search > Tracking**

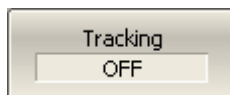

### 6.1.7.5 Search Range

The user can set the search range for the marker position search by setting the stimulus limits. This function involves the following additional features:



- search range coupling, which allows the user to define the same search range for all the traces of a channel;
- vertical line indication of the search range limits.

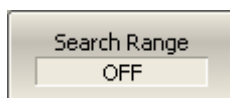

To enable/disable the search range, use the following softkeys:

**Markers > Marker Search > Search Range**

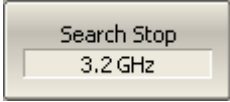
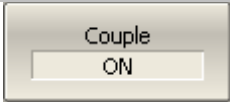

	<p>To set the search range limits, use the following softkeys:</p>
	<p><b>Markers &gt; Marker Search &gt; Search Start</b></p>
	<p><b>Markers &gt; Marker Search &gt; Search Stop</b></p>
	<p>To enable/disable search range coupling, use the following softkeys:</p>
	<p><b>Markers &gt; Marker Search &gt; Couple</b></p>
	<p>To enable/disable search range limits indication, use the following softkeys:</p>
	<p><b>Markers &gt; Marker Search &gt; Search Range Lines</b></p>

## 6.1.8 Marker Math Functions

Marker math functions are the functions, which use markers for calculating of various trace characteristics. Four marker math functions are available:

- Statistics;
- Bandwidth Search;
- Flatness;
- RF Filter.

### 6.1.8.1 Trace Statistics

The *trace statistics* feature allows the user to determine and view such trace parameters as mean, standard deviation, and peak-to-peak. The trace statistics range can be defined by two markers (See Figure 61).

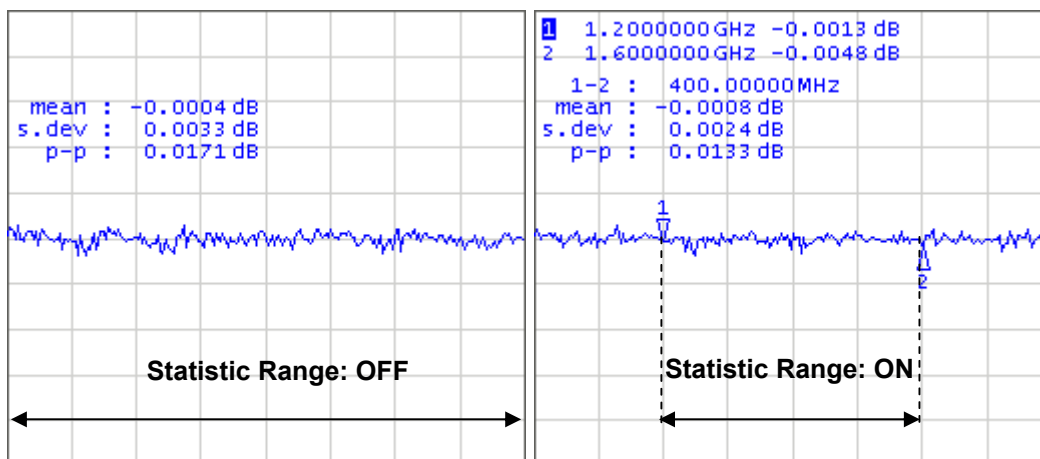
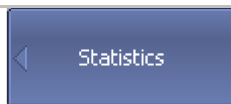

Figure 61 Trace statistics

Table 23 Statistics parameters

Symbol	Definition	Formula
<b>mean</b>	Arithmetic mean	$M = \frac{1}{N} \cdot \sum_{i=1}^N x_i$
<b>s.dev</b>	Standard deviation	$\sqrt{\frac{1}{N-1} \cdot \sum_{i=1}^N (x_i - M)^2}$
<b>p-p</b>	Peak-to-Peak: difference between the maximum and minimum values	Max - Min



To enable/disable trace statistics function, use the following softkeys:

**Markers > Marker Math > Statistics > Statistics**

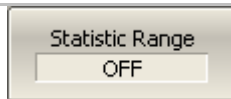
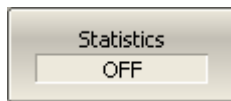

To enable/disable trace statistics range, use the following softkeys:

**Markers > Marker Math > Statistics > Statistic Range**

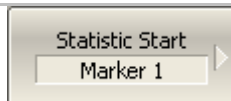

To set the start/stop markers of the statistics range, use the following softkeys:

**Markers > Marker Math > Statistics > Statistic Start**

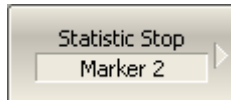

**Markers > Marker Math > Statistics > Statistic Stop**



### 6.1.8.2 Bandwidth Search

The *bandwidth search* function allows the user to determine and view the following parameters of a passband or a stopband: bandwidth, center frequency, lower frequency, higher frequency, Q value, and insertion loss (See Figure 62). In the figure, F1 and F2 are the lower and higher cutoff frequencies of the band respectively.

The bandwidth search is executed from the reference point. The user can select as reference point the active marker or the maximum of the trace. The bandwidth search function determines the lower and higher cutoff frequencies, which are apart from the reference point response by *bandwidth value* defined by the user (usually  $-3$  dB).

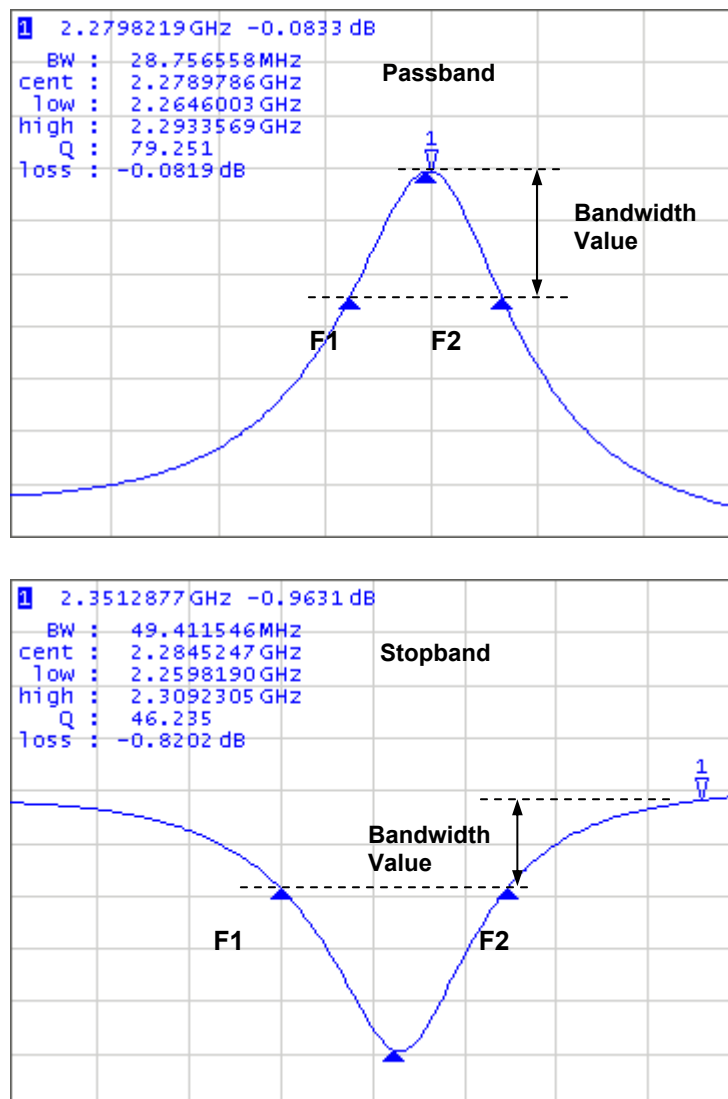
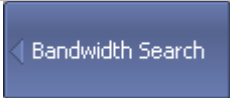
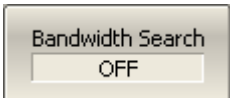
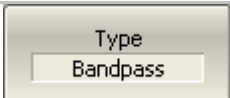

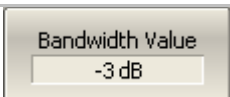

Figure 62 Bandwidth search

Table 24 Bandwidth parameters

Parameter Description	Symbol	Definition	Formula
Bandwidth	<b>BW</b>	The difference between the higher and lower cutoff frequencies	$F2 - F1$
Center Frequency	<b>cent</b>	The midpoint between the higher and lower cutoff frequencies	$(F1+F2)/2$
Lower Cutoff Frequency	<b>low</b>	The lower frequency point of the intersection of the bandwidth cutoff level and the trace	$F1$
Higher Cutoff Frequency	<b>high</b>	The higher frequency point of the intersection of the bandwidth cutoff level and the trace	$F2$
Quality Factor	<b>Q</b>	The ratio of the center frequency to the bandwidth	$\text{Cent}/\text{BW}$
Loss	<b>loss</b>	The trace measured value in the reference point of the bandwidth search	-

	<p>To enable/disable bandwidth search function, use the following softkeys:</p>
	<p><b>Markers &gt; Marker Math &gt; Bandwidth Search &gt; Bandwidth Search</b></p>
	<p>Set the bandwidth search type by softkeys:</p> <p><b>Markers &gt; Marker Math &gt; Bandwidth Search &gt; Type</b></p>
<p>The type and the softkey label toggle between <b>Bandpass</b> and <b>Notch</b> settings.</p>	
	<p>To set the search reference point, use the following softkeys:</p>
<p><b>Markers &gt; Marker Math &gt; Bandwidth Search &gt; Search Ref To</b></p>	
<p>The type and the softkey label toggle between <b>Max</b> and <b>Marker</b> settings.</p>	
	<p>To enter the bandwidth value, use the following softkeys:</p>
<p><b>Markers &gt; Marker Math &gt; Bandwidth Search &gt; Bandwidth Value</b></p>	

### 6.1.8.3 Flatness

The *flatness search* function allows the user to determine and view the following trace parameters: gain, slope, and flatness. The user sets two markers to specify the flatness search range (See Figure 63).

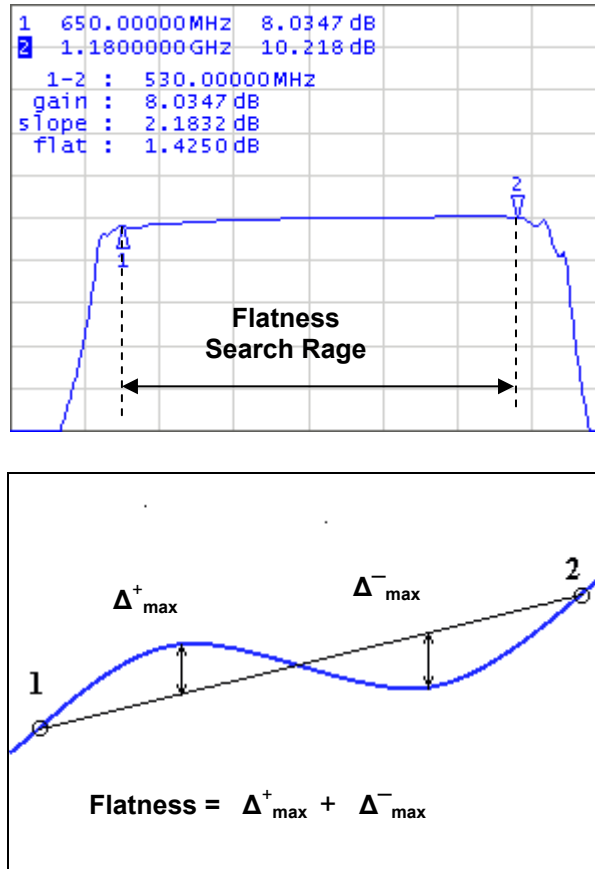
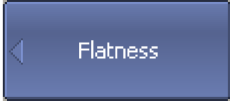

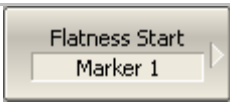
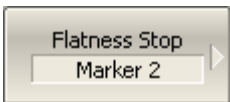

Figure 63 Flatness search

Table 25 Flatness parameters

Parameter Description	Symbol	Definition
Gain	<b>gain</b>	Marker 1 value
Slope	<b>slope</b>	Difference between marker 2 and marker 1 values.
Flatness	<b>flatness</b>	Sum of “positive” and “negative” peaks of the trace, which are measured from the line connecting marker 1 and marker 2 (See Figure 63).

	<p>To enable/disable the flatness search function, use the following softkeys:</p> <p><b>Markers &gt; Marker Math &gt; Flatness &gt; Flatness</b></p>
	<p><b>Markers &gt; Marker Math &gt; Flatness &gt; Flatness</b></p>
	<p>To select the markers specifying the flatness search range, use softkeys:</p> <p><b>Markers &gt; Marker Math &gt; Flatness &gt; Flatness Start</b></p>
	<p><b>Markers &gt; Marker Math &gt; Flatness &gt; Flatness Stop</b></p>

#### 6.1.8.4 RF Filter Statistics

The *RF filter statistics* function allows the user to determine and view the following filter parameters: loss, peak-to-peak in a passband, and rejection in a stopband. The passband is specified by the first pair of markers, the stopband is specified by the second pair of markers (See Figure 64).

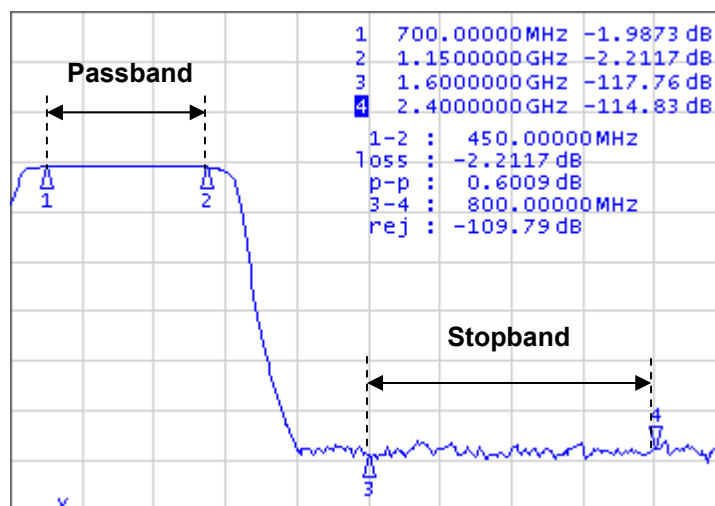
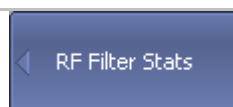

Figure 64 RF filter statistics

Table 26 RF filter statistics parameters

Parameter Description	Symbol	Definition
Loss in passband	<b>loss</b>	Minimum value in the passband
Peak-to-peak in passband	<b>p-p</b>	Difference between maximum and minimum in the passband
Reject	<b>rej</b>	Difference between maximum in stopband and minimum in passband



To enable/disable the RF filter statistics function, use the following softkeys:

**Markers > Marker Math > RF Filter Stats > RF Filter Stats**

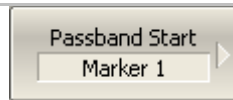
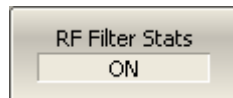

To select the markers specifying the passband, use the following softkeys:

**Markers > Marker Math > RF Filter Stats > Passband Start**



**Markers > Marker Math > RF Filter Stats > Passband Stop**



To select the markers specifying the stopband, use the following softkeys:

**Markers > Marker Math > RF Filter Stats > Stopband Start**

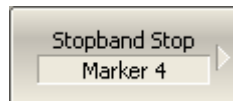



**Markers > Marker Math > RF Filter Stats > Stopband Stop**

### 6.1.9 Marker Functions

Using the current position of a marker you can perform settings of the following parameters:

- Stimulus start;
- Stimulus stop;
- Stimulus center;
- Reference level;
- Electrical delay.

Before performing the settings, first activate the marker.

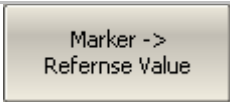
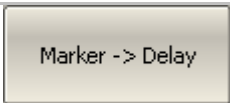
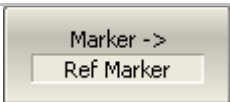
	<p>To set the stimulus start, use the following softkeys:</p> <p><b>Markers &gt; Marker Functions &gt; Marker-&gt;Start</b></p>
	
	<p>To set the stimulus stop, use the following softkeys:</p> <p><b>Markers &gt; Marker Functions &gt; Marker-&gt;Stop</b></p>
	<p>To set the stimulus center, use the following softkeys:</p> <p><b>Markers &gt; Marker Functions &gt; Marker-&gt;Center</b></p>
	<p>To set the reference level, use the following softkeys:</p> <p><b>Markers &gt; Marker Functions &gt; Marker-&gt;Ref Value</b></p>
	<p>To set the electrical delay, use the following softkeys:</p> <p><b>Markers &gt; Marker Functions &gt; Marker-&gt;Delay</b></p>
	<p>To set reference marker to the active marker point, use the following softkeys:</p> <p><b>Markers &gt; Marker Functions &gt; Marker-&gt;Ref Marker</b></p>

## 6.2 Memory Trace Function

For each data trace displayed on the screen a so-called memory trace can be created. The memory trace is displayed in the same color as the main data trace, but its brightness is twice lower<sup>1</sup>.

The data trace shows the currently measured data and is continuously being updated as the measurement goes on.

The memory trace is a data trace saved into the memory. It is created from the current measurement when the user is clicking the corresponding softkey. After that, the two traces become displayed on the screen – the data trace and the memory trace. The user can customize the trace indication.

<sup>1</sup> The color and brightness of the data and memory traces can be customized by the user (See section 8.6).

The trace status field will indicate the following:

- **D&M** – data trace and memory trace are displayed;
- **M** – only memory trace is displayed;
- **OFF** – both traces are not displayed
- *Empty field* – only data trace is displayed.

The memory trace bears the following features of the data trace (which if changed, will **clear** the memory):

- frequency range,
- number of points,
- sweep type.

The memory trace has the following settings common with the data trace (which if changed, modifies the both traces):

- format,
- scale,
- smoothing,
- electrical delay.

The following data trace settings (if changed after the memory trace creation) do not influence the memory trace:

- power in frequency sweep mode,
- frequency in power sweep mode,
- measured parameter (S-parameter),
- IF bandwidth,
- averaging,
- calibration.

The memory trace can be used for math operations with the data trace. The resulting trace of such an operation will replace the data trace. The math operations with memory and data traces are performed in complex values.

The following four math operations are available:

<b>Data / Memory</b>	Divides the measured data by the data in the memory trace. The trace status field indicates: <b>D/M</b> .
<b>Data * Memory</b>	Multiplies the measured data by the memory trace. The trace status field indicates: <b>D*M</b> .
<b>Data - Memory</b>	Subtracts a memory trace from the measured data. The trace status field indicates: <b>D-M</b> .
<b>Data + Memory</b>	Adds the measured data to the data in the memory trace. The trace status field indicates: <b>D+M</b> .

### 6.2.1 Saving Trace into Memory

The memory trace function can be applied to the individual traces of the channel. Before you enable this function, first activate the trace.

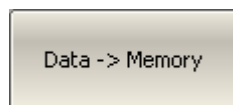
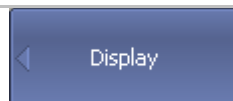

To save a trace into the memory, use the following softkeys:

**Display > Data->Memory**



## 6.2.2 Trace Display Setting



To set the type of data to be displayed on the screen, use the following softkeys:

**Display > Display >**

**Data | Memory | Data & Memory | OFF**

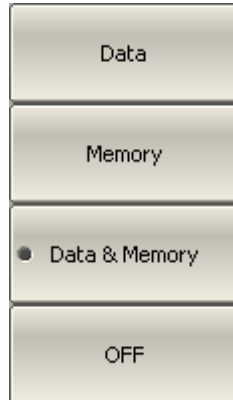

To access math operations, use the following softkeys:

**Display > Data Math**

**Data/Mem | Data \* Mem | Data - Mem | Data + Mem | OFF**

## 6.2.3 Mathematical Operations



To access math operations, use the following softkeys:

**Display > Data Math**

**Data/Mem | Data \* Mem | Data - Mem | Data + Mem | OFF**



## 6.3 Fixture Simulation

The fixture simulation function enables you to emulate the measurement conditions other than those of the real setup. The following conditions can be simulated:

- Port Z conversion;
- De-embedding;
- Embedding.

Before starting the fixture simulation, first activate the channel. The simulation function will affect all the traces of the channel.

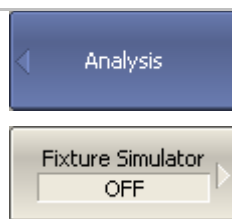

To open the fixture simulation menu, use the following softkeys:

**Analysis > Fixture Simulator**

### Note

The **Fixture Simulator** softkey label indicates the following:

**ON** – at least one of the fixture simulation functions is enabled,

**OFF** – all fixture simulation functions are disabled.

### 6.3.1 Port Z Conversion

Port Z conversion is a function of transformation of the S-parameters measured during port wave impedance change simulation (See Figure 65).

### Note

The value of the test port impedance is defined in the process of calibration. It is determined by the characteristic impedance of the calibration kit and the value is entered by the user as described in section 5.2.12.

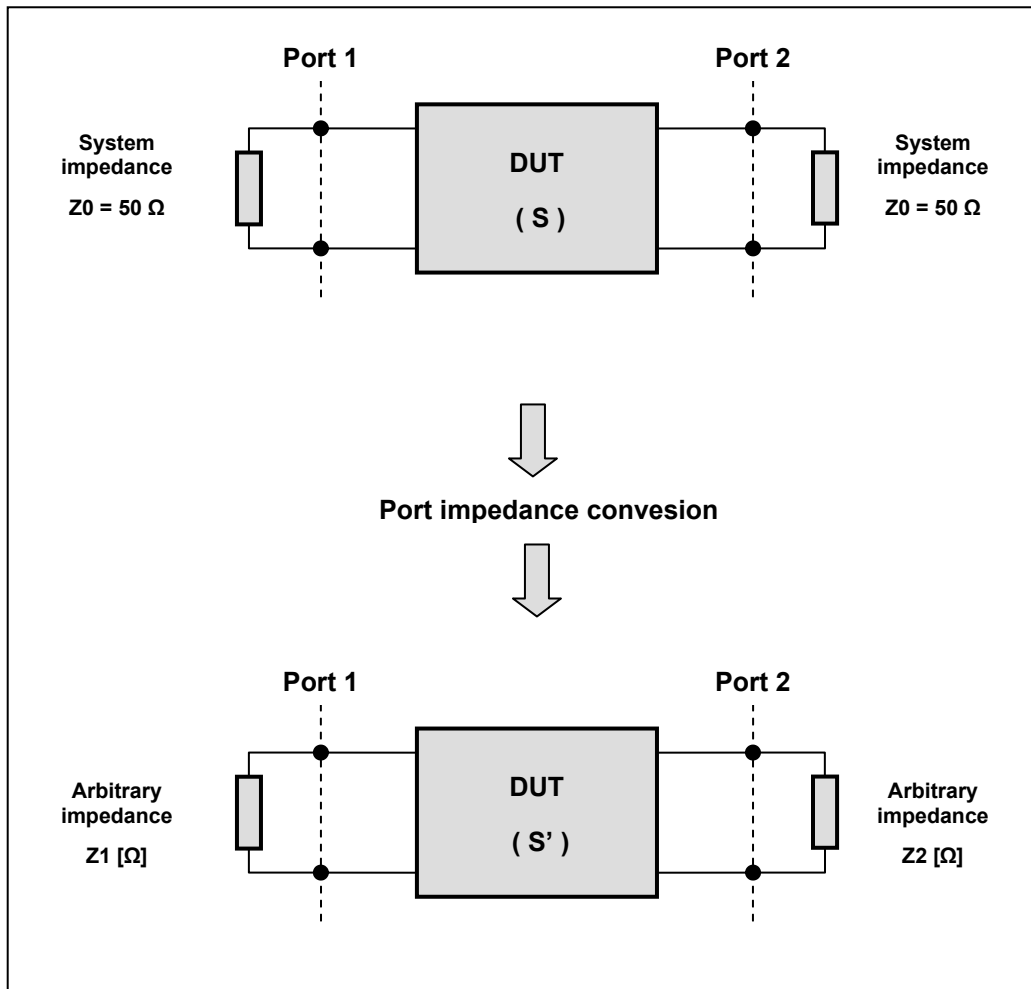

Figure 65 Port Z conversion

<input type="checkbox"/> Port ZConversion	To enable/disable the port impedance conversion function, toggle <b>Port Z Conversion</b> softkey.
<input type="checkbox"/> Port ZConversion OFF	
Port1 Z0 150 Ω	To enter the value of the simulated impedance of Port 1, use <b>Port 1 Z0</b> softkey.
Port2 Z0 150 Ω	To enter the value of the simulated impedance of Port 2, use <b>Port 2 Z0</b> softkey.

### 6.3.2 De-embedding

De-embedding is a function of the S-parameter transformation by removing of some circuit effect from the measurement results.

The circuit being removed should be defined in the data file containing S-parameters of this circuit. The circuit should be described as a 2-port in Touchstone file (extension .s2p), which contains the S-parameter table:  $S_{11}$ ,  $S_{21}$ ,  $S_{12}$ ,  $S_{22}$  for a number of frequencies.

The de-embedding function allows to mathematically exclude from the measurement results the effect of the fixture circuit existing between the calibration plane and the DUT in the real network. The fixture is used for the DUTs, which cannot be directly connected to the test ports.

The de-embedding function shifts the calibration plane closer to the DUT, so as if the calibration has been executed of the network with this circuit removed (See Figure 66).

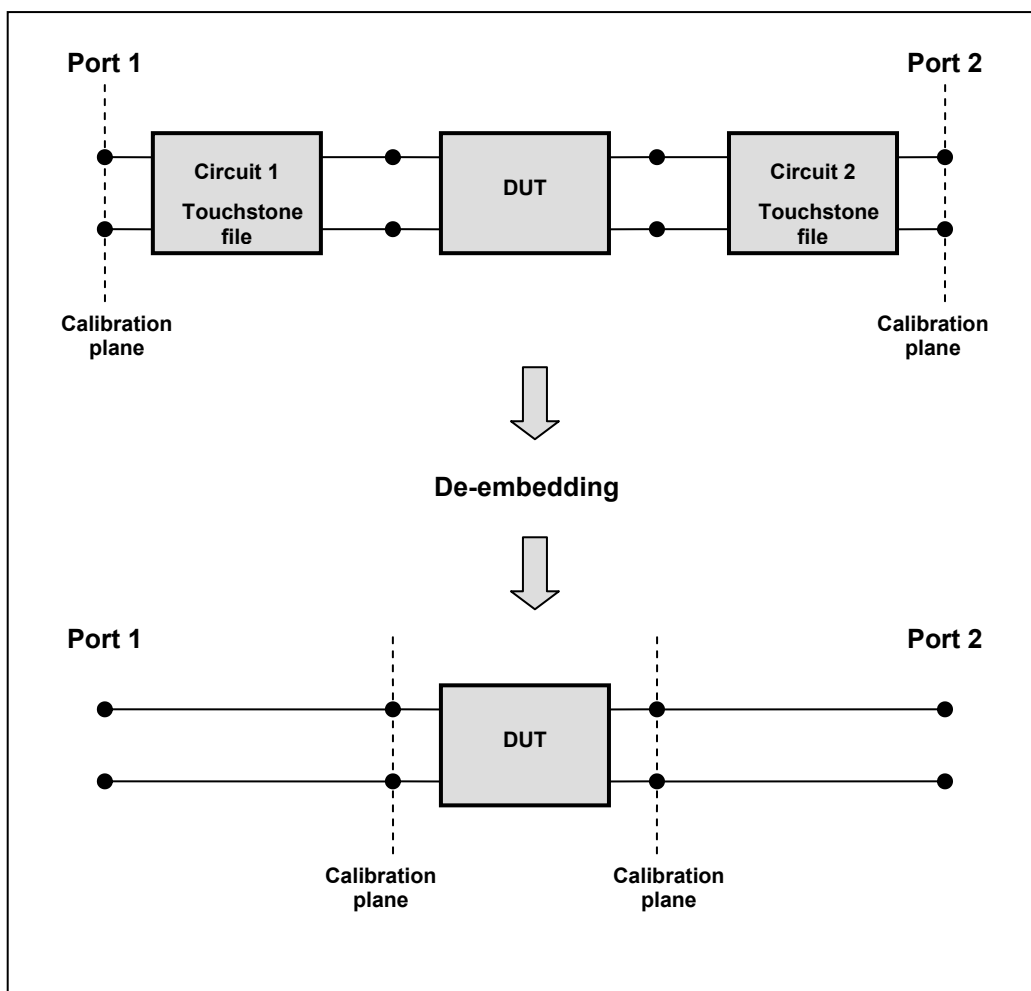
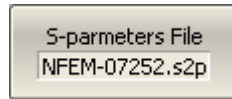
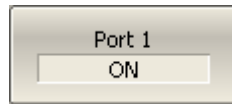

Figure 66 De-embedding



To enable/disable the de-embedding function for Port 1, use the following softkeys:

**Analysis > Fixture Simulator > De-Embedding > Port 1.**

To enter the file name of the de-embedded circuit S-parameters of Port 1, use the following softkeys:

**Analysis > Fixture Simulator > De-Embedding > S-parameters File**

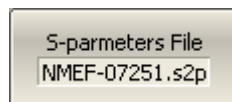
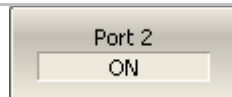

To enable/disable the de-embedding function for Port 2, use the following softkeys:

**Analysis > Fixture Simulator > De-Embedding > Port 2.**

To enter the file name of the de-embedded circuit S-parameters of Port 2, use the following softkeys:

**Analysis > Fixture Simulator > De-Embedding > S-parameters File**

Note

If S-parameters file is not specified, the softkey of the function activation will be grayed out.

### 6.3.3 Embedding

Embedding is a function of the S-parameter transformation by integration of some virtual circuit into the real network (See Figure 67). The embedding function is an inverted de-embedding function.

The circuit being integrated should be defined in the data file containing S-parameters of this circuit. The circuit should be described as a 2-port in Touchstone file (extension .s2p), which contains the S-parameter table:  $S_{11}$ ,  $S_{21}$ ,  $S_{12}$ ,  $S_{22}$  for a number of frequencies.

The embedding function allows to mathematically simulate the DUT parameters after adding of the fixture circuits.

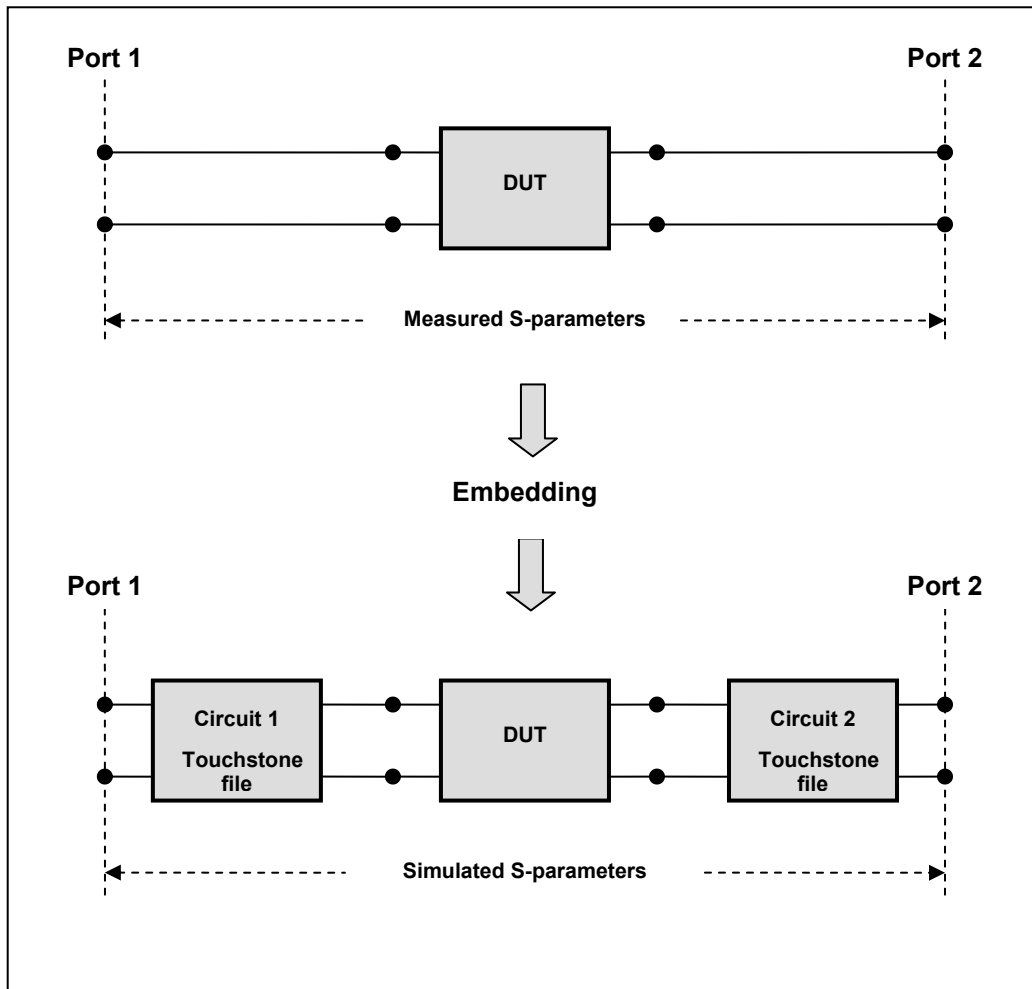
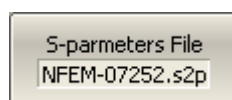
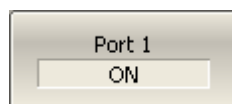
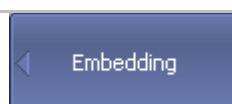

Figure 67 Embedding



To enable/disable the embedding function for Port 1, use the following softkeys:

**Analysis > Fixture Simulator > Embedding > Port 1.**

To enter the file name of the embedded circuit S-parameters of Port 1, use the following softkeys:

**Analysis > Fixture Simulator > Embedding > S-parameters File**

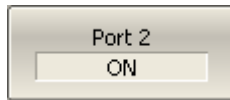

To enable/disable the embedding function for Port 2, use the following softkeys:



**Analysis > Fixture Simulator > Embedding > Port 2.**

To enter the file name of the embedded circuit S-parameters of Port 2, use the following softkeys:

**Analysis > Fixture Simulator > Embedding > S-parameters File**

**Note** If S-parameters file is not specified, the softkey of the function activation will be grayed out.

## 6.4 Time Domain Transformation

The Analyzer measures and displays parameters of the DUT in frequency domain. Time domain transformation is a function of mathematical modification of the measured parameters in order to obtain the time domain representation.

For time domain transformation Z-transformation and frequency domain window function are applied.

The time domain transformation can be activated for separate traces of a channel. The current frequency parameters ( $S_{11}$ ,  $S_{21}$ ,  $S_{12}$ ,  $S_{22}$ ) of the trace will be transformed into the time domain.

**Note** Traces in frequency and time domains can simultaneously belong to one channel. The stimulus axis label will be displayed for the active trace, in frequency or time units.

The transformation function allows for setting of the measurement range in time domain within Z-transformation ambiguity range. The ambiguity range is determined by the measurement step in the frequency domain:

$$\Delta T = \frac{1}{\Delta F}; \quad \Delta F = \frac{F_{\max} - F_{\min}}{N - 1}$$

The time domain function allows to select the following transformation types:

- Bandpass mode simulates the impulse bandpass response. It allows the user to obtain the response for circuits incapable of direct current passing. The frequency range is arbitrary in this mode. The time domain resolution in this mode is twice lower than it is in the lowpass mode;
- Lowpass mode simulates lowpass impulse and lowpass step responses. It is applied to the circuits passing direct current, and the direct component (in point  $F=0$  Hz) is interpolated from the start frequency ( $F_{min}$ ) of the range. In this mode the frequency range represents a harmonic grid where the frequency value at each frequency point is an integer multiple of the start frequency of the range  $F_{min}$ . The time domain resolution is twice higher than it is in the bandpass mode.

The time domain transformation function applies Kaiser window for initial data processing in frequency domain. The window function allows to reduce the ringing (side lobes) in the time domain. The ringing is caused by the abrupt change of the data at the limits of the frequency domain. But while side lobes are reduced, the main pulse or front edge of the lowpass step becomes wider.

The Kaiser window is described by  $\beta$  parameter, which smoothly fine-tune the window shape from minimum (rectangular) to maximum. The user can fine-tune the window shape or select one of the three preprogrammed windows:

- **Minimum** (rectangular);
- **Normal**;
- **Maximum**.

Table 27 Preprogrammed window types

Window	Lowpass Impulse		Lowpass Step	
	Side Lobes Level	Pulse Width	Side Lobes Level	Edge Width
Minimum	- 13 dB	$\frac{0.6}{F_{max} - F_{min}}$	- 21 dB	$\frac{0.45}{F_{max} - F_{min}}$
Normal	- 44 dB	$\frac{0.98}{F_{max} - F_{min}}$	- 60 dB	$\frac{0.99}{F_{max} - F_{min}}$
Maximum	- 75 dB	$\frac{1.39}{F_{max} - F_{min}}$	- 70 dB	$\frac{1.48}{F_{max} - F_{min}}$



### 6.4.1 Time Domain Transformation Activating

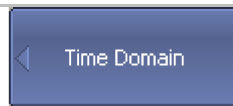

To enable/disable time domain transformation function, use the following softkeys:

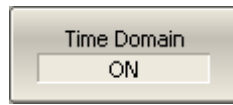

**Analysis > Time Domain > Time Domain**

Note

Time domain transformation function is accessible only in linear frequency sweep mode.

### 6.4.2 Time Domain Transformation Span

To define the span of time domain representation, you can set its start and stop, or center and span values.

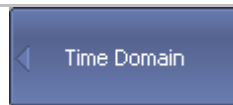

To set the start and stop limits of the time domain range, use the following softkeys:

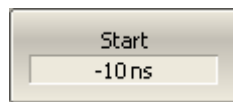

**Analysis > Time Domain > Start**

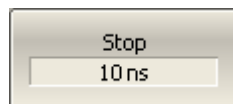

**Analysis > Time Domain > Stop**

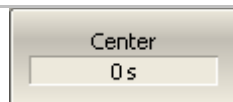

To set the center and span of the time domain, use the following softkeys:

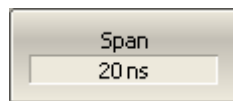

**Analysis > Time Domain > Center**

**Analysis > Time Domain > Span**

### 6.4.3 Time Domain Transformation Type

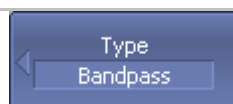

To set the time domain transformation type, use the following softkeys:

**Analysis > Time Domain > Type >**

**Bandpass | Lowpass Impulse | Lowpass Step**

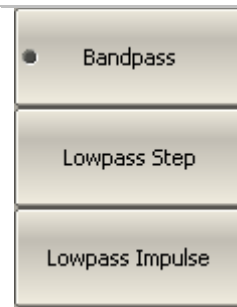

#### 6.4.4 Time Domain Transformation Window Shape Setting

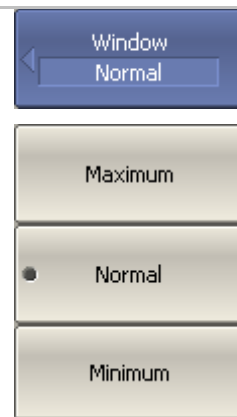

To set the window shape, use the following softkeys:

**Analysis > Time Domain > Window >**

**Minimum | Normal | Maximum**

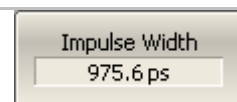

To set the window shape for the specific impulse width or front edge width, use the following softkeys:

**Analysis > Time Domain > Window > Impulse Width**

The setting values are limited by the specified frequency range. The bottom limit corresponds to the value implemented in the minimum (rectangular) window. The top limit corresponds to the value implemented in the maximum window.

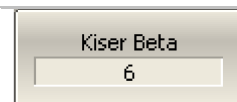

To set the window shape for the specific  $\beta$ -parameter of the Kaiser-Bessel filter, use the following softkeys:

**Analysis > Time Domain > Window > Kaiser Beta**

The available  $\beta$  values are from 0 to 13. 0 corresponds to minimum window, 6 corresponds to normal window, 13 corresponds to maximum window.

#### Note

The impulse width and  $\beta$  of the Kaiser-Bessel filter are the dependent parameters. When you set one of the parameters the other one will be adjusted automatically.

### 6.4.5 Frequency Harmonic Grid Setting

If lowpass impulse or lowpass step transformation is enabled, the frequency range will be represented as a harmonic grid. The frequency values in measurement points are integer multiples of the start frequency  $F_{min}$ . The Analyzer is capable of creating a harmonic grid for the current frequency range automatically.

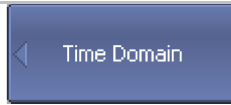

To create a harmonic grid for the current frequency range, use the following softkeys:

**Analysis > Time Domain > Set Frequency Low Pass**

Note

The frequency range will be transformed as follows:

$F_{max} > N \times 0.3 \text{ MHz}$	$F_{max} < N \times 0.3 \text{ MHz}$
$F_{min} = F_{max} / N$	$F_{min} = 0.3 \text{ MHz},$ $F_{max} = N \times 0.3 \text{ MHz}$

## 6.5 Time Domain Gating

Time domain gating is a function, which mathematically removes the unwanted responses in time domain. The function performs time domain transformation and applies reverse transformation back to frequency domain to the user-defined span in time domain. The function allows the user to remove spurious effects of the fixture devices from the frequency response, if the useful signal and spurious signal are separable in time domain.

---

Note	Use <i>time domain</i> function for viewing the layout of useful and spurious responses. Then enable <i>time domain gating</i> and set the gate span to remove as much of spurious response as possible. After that disable the time domain function and view the response without spurious effects in frequency domain.
------	--

---

The function involves two types of time domain gating:

- *bandpass* – removes the response outside the gate span,
- *notch* – removes the response inside the gate span.

The rectangular window shape in frequency domain leads to spurious sidelobes due to sharp signal changes at the limits of the window. The following gate shapes are offered to reduce the sidelobes:

- *maximum*;
- *wide*;
- *normal*;
- *minimum*.

The minimum window has the shape close to rectangular. The maximum window has more smoothed shape. From minimum to maximum window shape, the sidelobe level increases and the gate resolution reduces. The choice of the window shape is always a trade-off between the gate resolution and the level of spurious sidelobes. The parameters of different window shapes are represented in Table 28.

Table 28 Time domain gating window shapes

Window Shape	Bandpass Sidelobe Level	Gate Resolution (Minimum Gate Span)
Minimum	- 48 dB	$\frac{2.8}{F_{\max} - F_{\min}}$
Normal	- 68 dB	$\frac{5.6}{F_{\max} - F_{\min}}$
Wide	- 57 dB	$\frac{8.8}{F_{\max} - F_{\min}}$
Maximum	- 70 dB	$\frac{25.4}{F_{\max} - F_{\min}}$

### 6.5.1 Time Domain Gate Activating

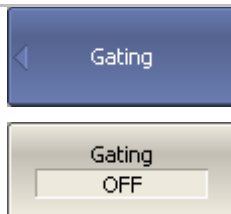

To enable/disable the time domain gating function: toggle the following softkey:

**Analysis > Gating > Gating**

Note

Time domain gating function is accessible only in linear frequency sweep mode.

### 6.5.2 Time Domain Gate Span

To define the span of time domain gate, you can set its start and stop, or center and span values.

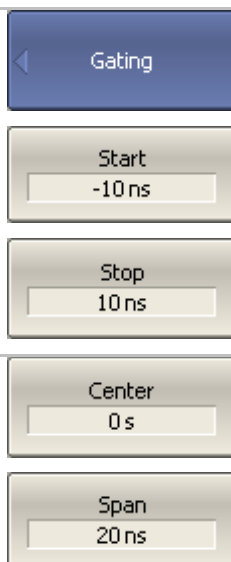

To the start and stop of the time domain gate, use the following softkeys:

**Analysis > Gating > Start**

**Analysis > Gating > Stop**

To set the center and span of the time domain gate, use the following softkeys:

**Analysis > Gating > Center**

**Analysis > Gating > Span**

### 6.5.3 Time Domain Gate Type

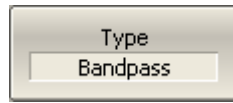
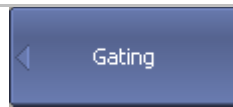

To select the type of the time domain window, use the following softkeys:

**Analysis > Gating > Type**

Toggle the type between **Bandpass** and **Notch**.

### 6.5.4 Time Domain Gate Shape Setting

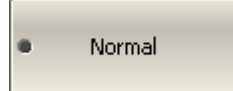
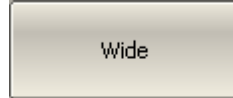
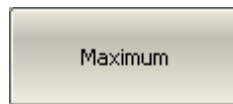
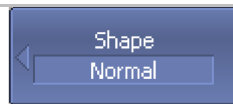

To set the time domain gate shape, use the following softkeys:

**Analysis > Gating > Shape >**

**Minimum | Normal | Wide | Maximum**

## 6.6 S-Parameter Conversion

S-parameter conversion function allows for conversion of measurement results ( $S_{ab}$ ) to the following parameters:

Parameter	Equation
Impedance in reflection measurement ( $Z_r$ )	$Z_r = Z_{0a} \cdot \frac{1 + S_{aa}}{1 - S_{aa}},$
Admittance in reflection measurement ( $Y_r$ )	$Y_r = \frac{1}{Z_r}$
Impedance in transmission measurement ( $Z_t$ )	$Z_t = \frac{2 \cdot \sqrt{Z_{0a} \cdot Z_{0b}}}{S_{ab}} - (Z_{0a} + Z_{0b}),$
Admittance in transmission measurement ( $Y_t$ )	$Y_t = \frac{1}{Z_t}$
Inverse S-parameter	$\frac{1}{S_{ab}}$
Equivalent admittance in transmission shunt measurements ( $Y_{tsh}$ )	$Y_{tsh} = \frac{2 \cdot \sqrt{Y_{0a} \cdot Y_{0b}}}{S_{ab}} - (Y_{0a} + Y_{0b})$
Equivalent impedance in transmission shunt measurements ( $Z_{tsh}$ )	$Z_{tsh} = \frac{1}{Y_{tsh}},$
S-parameter complex conjugate	$S_{ab}^*$

$Z_{0a}$  – characteristic impedance of Port a,

$Z_{0b}$  – characteristic impedance of Port b,

$S_{ab}$  – measured S-parameter (a and b are the port identifiers).

$$Y_{0a} = \frac{1}{Z_{0a}}, \quad Y_{0b} = \frac{1}{Z_{0b}}$$

Note	Equations for $Z_r$ , $Z_t$ , $Y_r$ , $Y_t$ are approximate. The general method of converting S - parameters to Z, Y, H, T, ABCD - parameters is presented in the next section. The reason for using the approximate method is the measurement speed, as only one S - parameter is used in the calculations, whereas the general method requires measurement of the full matrix of S-parameters.
------	--

The S-parameter conversion function can be applied to an individual trace of a channel. Before enabling the function, first activate the trace.

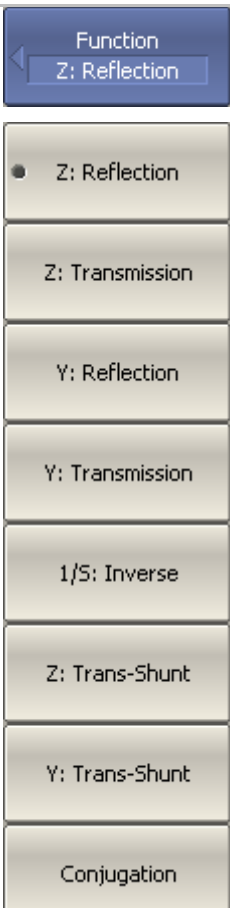
 <p>The screenshot shows a blue softkey labeled 'Conversion' with a left-pointing arrow. Below it is a grey softkey labeled 'Conversion' with a white toggle switch currently in the 'OFF' position.</p>	<p>To enable/disable the conversion, use the following softkeys:</p> <p><b>Analysis &gt; Conversion &gt; Conversion</b></p>
 <p>The screenshot shows a blue softkey labeled 'Function' with a left-pointing arrow and 'Z: Reflection' below it. Below this are eight grey softkeys, each with a white radio button to its left. The first radio button is selected. The options are: 'Z: Reflection', 'Z: Transmission', 'Y: Reflection', 'Y: Transmission', '1/S: Inverse', 'Z: Trans-Shunt', 'Y: Trans-Shunt', and 'Conjugation'.</p>	<p>To select the conversion type, use the following softkeys:</p> <p><b>Analysis &gt; Conversion &gt; Function &gt;</b></p> <p><b>Zr: Reflection  </b></p> <p><b>Zt: Transmission  </b></p> <p><b>Yr: Reflection  </b></p> <p><b>Yt: Transmission  </b></p> <p><b>1/S: Inverse  </b></p> <p><b>Ztsh: Trans-Shunt  </b></p> <p><b>Ytsh: Trans-Shunt  </b></p> <p><b>Conjugation</b></p>



Note	All conversion types are indicated in the trace status field, when enabled.
------	---



## 6.7 General S-Parameter Conversion

This section describes the most common method of transformation of the S-parameters to Z, Y, T, H, ABCD - parameters. The method is valid for complex and unique values of the port impedances. Z, Y, H, ABCD - parameters can be presented both in volume and in normalized form. The method is described in: Dean A. Frickey's "Conversions Between S, Z, Y, h, ABCD, and T Parameters which are Valid for Complex Source and Load Impedances".

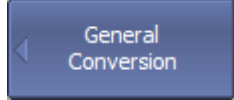
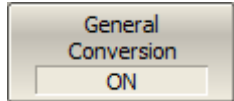
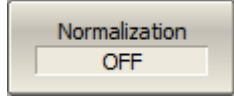
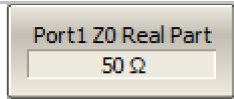
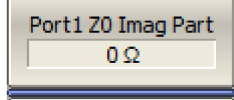
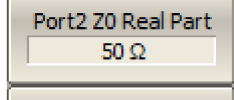
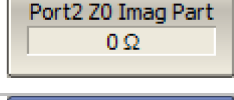
The function is applied to the channel as a whole. Before using this function, select the active channel.

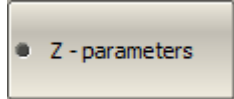
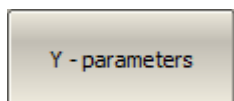
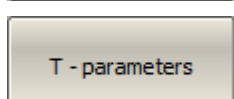
	<p>To enable/disable the general conversion, use the following softkeys:</p>
	<p><b>Analysis &gt; General Conversion &gt; General Conversion</b></p>
	<p>To enable/disable the normalization of Z, Y, H, ABCD - parameters, use the following softkeys:</p>
<p><b>Analysis &gt; General Conversion &gt; Normalization</b></p>	
   	<p>Set the real and imaginary parts of complex port impedances using the following softkeys:</p>
   	<p>To select the conversion type, use the following softkeys:</p>
<p><b>Analysis &gt; General Conversion &gt; Conversion Type &gt;</b></p>	
<p><b>Z - parameters  </b></p>	
<p><b>Y - parameters  </b></p>	
<p><b>T - parameters  </b></p>	
<p><b>H - parameters  </b></p>	
<p><b>ABCD - parameters</b></p>	

H - parameters

ABCD -  
parameters

---

Note

**Conv** is indicated in the trace status field, when general conversion is enabled.

---

## 6.8 Limit Test

The limit test is a function of automatic pass/fail judgment for the trace of the measurement result. The judgment is based on the comparison of the trace to the limit line set by the user.

The limit line can consist of one or several segments (See Figure 68). Each segment checks the measurement value for failing whether upper or lower limit. The limit line segment is defined by specifying the coordinates of the beginning ( $X_0, Y_0$ ) and the end ( $X_1, Y_1$ ) of the segment, and type of the limit. The MAX or MIN limit types check if the trace falls outside of the upper or lower limit respectively.

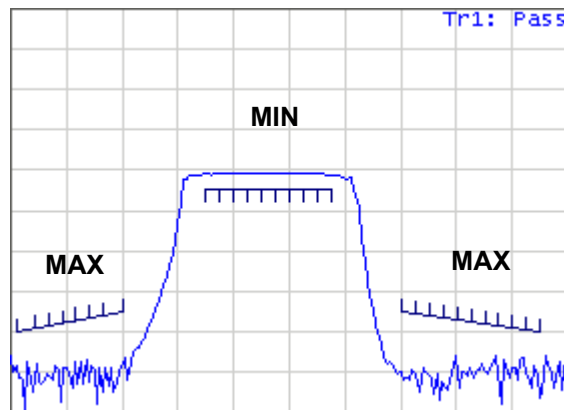

Figure 68 Limit line

The limit line is set by the user in the limit table. Each row in the table describes one segment of the line. Limit table editing is described below. The table can be saved into a \*.lim file.

The display of the limit lines on the screen can be turned on/off independently of the status of the limit test function.

The result of the limit test is indicated in the upper right corner of the graph. If the measurement result passed the limit test, you will see the trace number and the result: **Tr1: Pass**.

If the measurement result failed, the result will be indicated in the following ways (See Figure 69):

- **Tr1: Fail** will be displayed in upper right corner of the graph;
- **Fail** sign will be displayed in red in the center of the window;
- The points of the trace, which failed the test will be highlighted in red;
- You will hear a beep.

**Fail** sign and the beep can be disabled by the user. For beep deactivation see section 8.5.

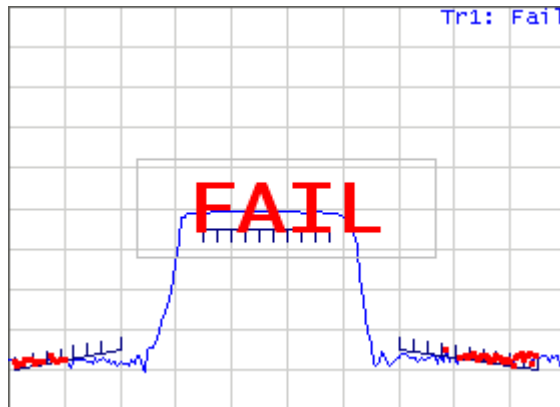
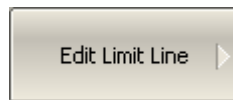

Figure 69 Test fail indication

### 6.8.1 Limit Line Editing





To access the limit line editing mode, use the following softkeys:

**Analysis > Limit Test > Edit Limit Line**

In the editing mode the limit table will appear in the lower part of the screen (See Figure 70). The limit table will be hidden when you quit the submenu.

	Type	Begin Stimulus	End Stimulus	Begin Response	End Response
1	MAX	10 MHz	400 MHz	-100 dB	-90 dB
2	MIN	700 MHz	1.2 GHz	-6 dB	-6 dB
3	MAX	1.4 GHz	2 GHz	-90 dB	-100 dB
4					

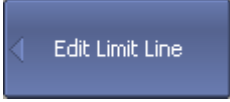
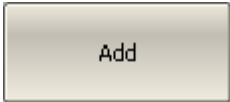
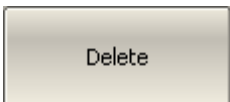
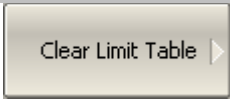
Figure 70 Limit line table

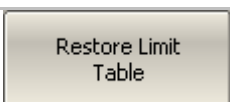
	To add a new row in the table, click <b>Add</b> . The new row will appear below the highlighted one.
	To delete a row from the table, click <b>Delete</b> . The highlighted row will be deleted.
	
	To clear the entire table, use <b>Clear Limit Table</b> softkey.
	To save the table into *.lim file, use <b>Save Limit Table</b> softkey.
	To open the table from a *.lim file, use <b>Restore Limit Table</b> softkey.

Navigating in the table to enter the values of the following parameters of a limit test segment:

<b>Type</b>	Select the segment type among the following: <ul style="list-style-type: none"> <li>▪ <b>MAX</b> – upper limit</li> <li>▪ <b>MIN</b> – lower limit</li> <li>▪ <b>OFF</b> – segment not used for the limit test</li> </ul>
<b>Begin Stimulus</b>	Stimulus value in the beginning point of the segment.
<b>End Stimulus</b>	Stimulus value in the ending point of the segment.
<b>Begin Response</b>	Response value in the beginning point of the segment.
<b>End Response</b>	Response value in the ending point of the segment.

## 6.8.2 Limit Test Enabling/Disabling

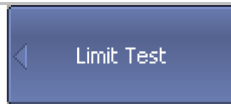

To enable/disable limit test function, use the following softkeys:

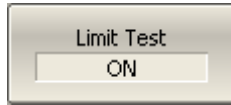

**Analysis > Limit Test > Limit Test**

## 6.8.3 Limit Test Display Management



To enable/disable display of a *limit line*, use the following softkeys:

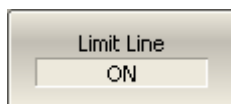

**Analysis > Limit Test > Limit Line**

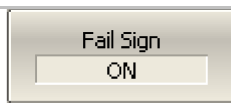

To enable/disable display of **Fail sign** in the center of the graph, use **Fail Sign** softkey.

## 6.8.4 Limit Line Offset

Limit line offset function allows the user to shift the segments of the limit line by the specified value along X and Y axes simultaneously.

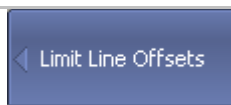

To define the limit line offset along X-axis, use the following softkeys:

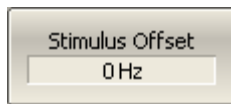

**Analysis > Limit Test > Limit Line Offsets > Stimulus Offset**

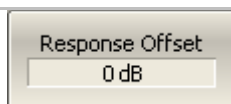

To define the limit line offset along Y-axis, use the following softkeys:

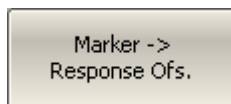

**Analysis > Limit Test > Limit Line Offsets > Response Offset**

Response offset can be set to the active marker position, using the following softkeys:

**Analysis > Limit Test > Limit Line Offsets > Marker -> Response Ofs**

## 6.9 Ripple Limit Test

Ripple limit test is an automatic pass/fail check of the measured trace data. The trace is checked against the maximum ripple value (*ripple limit*) defined by the user. The ripple value is the difference between the maximum and minimum response of the trace in the trace frequency band.

The ripple limit can include one or more segments (See Figure 71). Each segment provides the ripple limit for the specific frequency band. A segment is set by the frequency band and the ripple limit value.

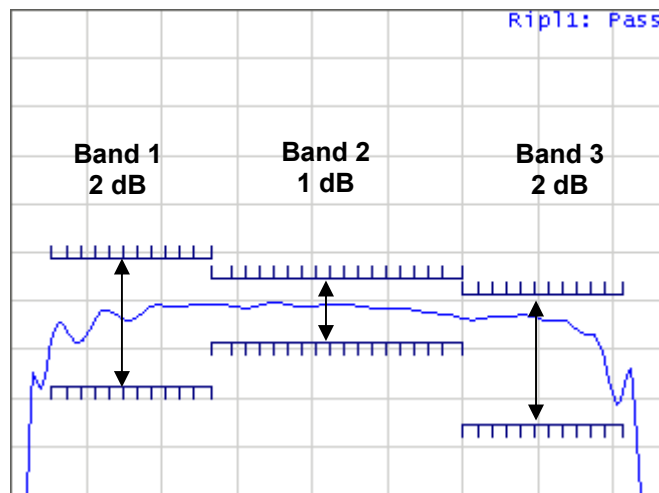

Figure 71 Ripple limits

The ripple limit settings are performed in the ripple limit table. Each row of the table describes the frequency band the ripple limit value. The ripple limit table editing is described below. The table can be saved into a \*.lim file.

The display of the limit lines on the screen can be turned on/off by the user.

The result of the ripple limit test is indicated in the upper right corner of the graph. If the measurement result passed the limit test, you will see the trace number and the result: **Ripl1: Pass**.

If the measurement result failed, the result will be indicated in the following ways (See Figure 72):

- **Ripl1: Fail** will be displayed in upper right corner of the graph;
- **Fail** sign will be displayed in red in the center of the window;
- You will hear a beep.

**Fail** sign and the beep can be disabled by the user. For beep deactivation see section 8.5.

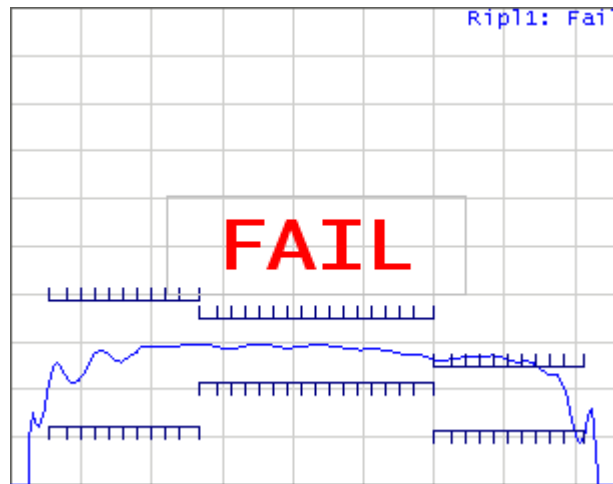

Figure 72 Test fail indication

The display of the ripple value can be enabled/disabled by the user in the ripple limit test status line in the upper right corner of the graph (See Figure 73). The ripple value is displayed for the band selected by the user. The ripple value can be represented as an *absolute* value or as a *margin* to the limit.

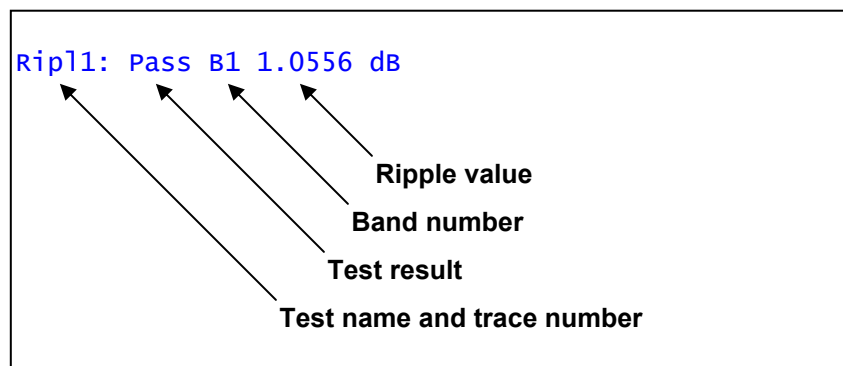
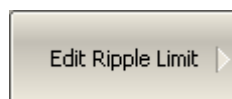
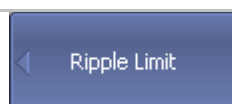

Figure 73 Ripple limit test status line

### 6.9.1 Ripple Limit Editing



To access the ripple limit editing mode, use the following softkeys:



**Analysis > Ripple Limit > Edit Ripple Limit**

In the editing mode the limit table will appear in the lower part of the screen (See Figure 74). The limit table will be hidden when you quit the submenu.

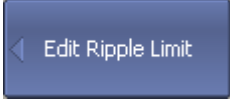
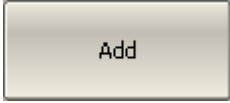
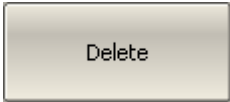

	Type	Begin Stimulus	End Stimulus	Ripple Limit
1	ON	640MHz	800MHz	4 dB
2	ON	800MHz	1.05 GHz	2 dB
3	ON	1.05 GHz	1.21GHz	3 dB
4				

Figure 74 Ripple limit table

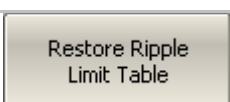
	To add a new row in the table, click <b>Add</b> . The new row will appear below the highlighted one.
	To delete a row from the table, click <b>Delete</b> . The highlighted row will be deleted.
	
	To clear the entire table, use <b>Clear Ripple Limit Table</b> softkey.
	To save the table into *.rlm file, use <b>Save Ripple Limit Table</b> softkey.
	To open the table from a *.rlm file, use <b>Recall Ripple Limit Table</b> softkey.

Navigating in the table to enter the values of the following parameters of a ripple limit test segment:

<b>Type</b>	Select the segment type among the following: <ul style="list-style-type: none"> <li>▪ <b>ON</b> – band used for the ripple limit test</li> <li>▪ <b>OFF</b> – band not used for the limit test</li> </ul>
<b>Begin Stimulus</b>	Stimulus value in the beginning point of the segment.
<b>End Stimulus</b>	Stimulus value in the ending point of the segment.
<b>Ripple Limit</b>	Ripple limit value.

## 6.9.2 Ripple Limit Enabling/Disabling

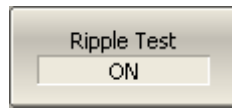
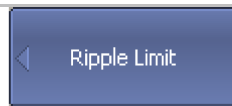

To enable/disable ripple limit test function, use the following softkeys:

**Analysis > Ripple Limit > Ripple Test**

## 6.9.3 Ripple Limit Test Display Management

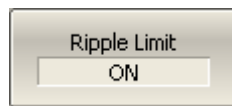
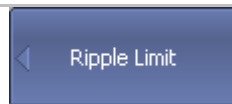

To enable/disable display of the *ripple limit line*, use the following softkeys:

**Analysis > Ripple Limit > Ripple Limit**

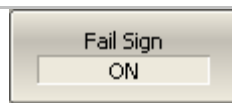

To enable/disable display of the **Fail** sign in the center of the graph, use the following softkeys:

**Analysis > Ripple Limit > Fail Sign.**

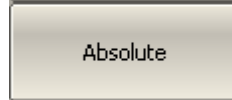
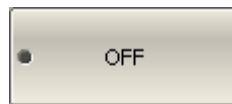

To enable/disable display of the ripple value, use the following softkeys:

**Analysis > Ripple Limit > Ripple Value >**

**OFF | Absolute | Margin**

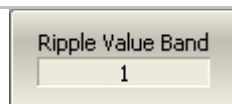

To enter the number of the band, whose ripple value should be displayed, use the following softkeys:

**Analysis > Ripple Limit > Ripple Value Band**

## 7 ANALYZER DATA OUTPUT

### 7.1 Analyzer State

The Analyzer state, calibration and measured data can be saved on the hard disk to an Analyzer state file and later uploaded back into the Analyzer program. The following four types of saving are available:

<b>State</b>	The Analyzer settings.
<b>State &amp; Cal</b>	The Analyzer settings and the table of calibration coefficients.
<b>State &amp; Trace</b>	The Analyzer settings and data traces <sup>1</sup> .
<b>All</b>	The Analyzer settings, table of calibration coefficients, and data traces <sup>1</sup> .

The Analyzer settings that become saved into the Analyzer state file are the parameters, which can be set in the following submenus of the softkey menu:

- All the parameters in **Stimulus** submenu;
- All the parameters in **Measurement** submenu;
- All the parameters in **Format** submenu;
- All the parameters in **Scale** submenu;
- All the parameters in **Average** submenu;
- All the parameters in **Display** submenu except for **Properties**;
- All the parameters of **Markers** submenu;
- All the parameters of **Analysis** submenu;
- **Ref Source** and **System Correction** parameters in **System** submenu.

To save and recall a state file, you can use ten softkeys labeled **State01**, ... **State10**. Each of the softkeys correspond to a \*.sta file having the same name.

---



<sup>1</sup> When recalling the state with saved data traces, the trigger mode will be automatically set to «Hold», so that the recalled traces are not erased by the currently measured data.

To have the Analyzer state automatically recalled after each start of the instrument use *Autorecall.sta* file. Use **Autorecall** softkey to save the corresponding file and thus enable this function.



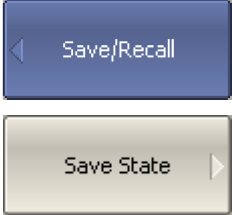

To disable the automatic recall of the Analyzer state, delete the *Autorecall.sta* file using the specific softkey.

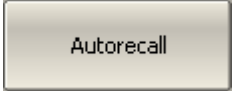
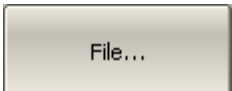
You can save and recall the files with arbitrary names. For this purpose use **File...** softkey, which will open the **Save as** dialog box.

### 7.1.1 Analyzer State Saving

	<p>To set the type of saving, use the following softkeys:</p> <p><b>Save/Recall &gt; Save Type &gt;</b></p> <p><b>State  </b></p> <p><b>State &amp; Cal  </b></p> <p><b>State &amp; Trace  </b></p> <p><b>All</b></p>
	<p>To save the state, use the following softkeys:</p> <p><b>Save/Recall &gt; Save State</b></p>
	<p>To save a state into one of the ten files, use <b>State01...State10</b> softkeys.</p> <p>A check mark in the left part of the softkey indicates that the state with the corresponding number is already saved.</p>
	<p>To save the state, which will be automatically recalled after each start of the Analyzer, use <b>Autorecall</b> softkey.</p> <p>A check mark on the softkey indicates that such a state is already saved.</p>
	<p>To save a state into the file with an arbitrary name use <b>File...</b> softkey.</p>

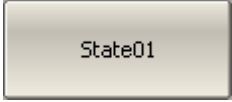
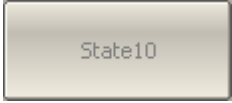
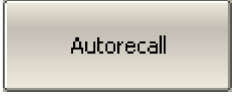
## 7.1.2 Analyzer State Recalling

	<p>To recall the state from a file of Analyzer state, use the following softkeys:</p>
	<p><b>Save/Recall &gt; Recall State</b></p>
	<p>Click the required softkey of the available <b>State01...State10</b>.</p>
<p>...</p>	<p>If the state with some number was not saved the corresponding softkey will be grayed out.</p>
	
	<p>You can select the state automatic recall file by clicking <b>Autorecall</b> softkey.</p>
	<p>To recall a state from the file with an arbitrary name, use <b>File...</b> softkey.</p>

## 7.1.3 Session Saving

When enabled, this function automatically saves a session on exit and resumes it when the Analyzer is turned on next time. The stored session parameters include the Analyzer settings, table of calibration coefficients, and data and memory traces.

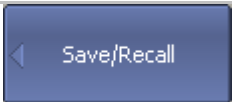
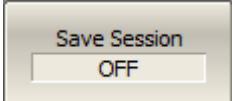
	<p>To enable the Save Session function, use the following softkeys:</p>
	<p><b>Save/Recall &gt; Save Session</b></p>



## 7.2 Channel State

A channel state can be saved into the Analyzer memory. The channel state saving procedure is similar to saving of the Analyzer state saving, and the same saving types (described in section 7.1) are applied to the channel state saving.



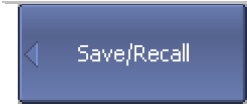

Unlike the Analyzer state, the channel state is saved into the Analyzer inner volatile memory (not to the hard disk) and is cleared when the power to the Analyzer is turned off. For channel state storage, there are four memory registers **A, B, C, D**.

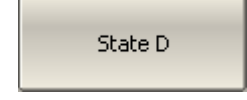
The channel state saving allows the user to easily copy the settings of one channel to another one.

### 7.2.1 Channel State Saving

	<p>To save the active channel state, use the following softkeys:</p>
	<p><b>Save/Recall &gt; Save Channel</b></p>
	<p>To save a state into one of the four memory registers, use <b>State A...State D</b> softkeys.</p>
<p>...</p>	<p>A check mark in the left part of the softkey indicates that the state with the corresponding number is already saved.</p>
	

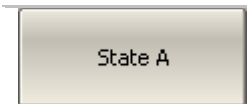
### 7.2.2 Channel State Recalling

	<p>To recall the active channel state, use the following softkeys:</p>
	<p><b>Save/Recall &gt; Recall Channel</b></p>
	<p>Click the required softkey of the available <b>State A...State D</b>.</p>
<p>...</p>	<p>If the state with some number was not saved the corresponding softkey will be grayed out.</p>
	

### 7.3 Trace Data CSV File

The Analyzer allows the use to save an individual trace data as a CSV file (comma separated values). The \*.CSV file contains digital data separated by commas. The active trace stimulus and response values in current format are saved to \*.CSV file.

Only one (active) trace data are saved to the file.

The trace data are saved to \*.CSV in the following format:

<b>F[0],</b>	<b>Data1,</b>	<b>Data2</b>
<b>F[1],</b>	<b>Data1,</b>	<b>Data2</b>
	...	
<b>F[N],</b>	<b>Data1,</b>	<b>Data2</b>

**F[n]** – frequency at measurement point n;

**Data1** – trace response in rectangular format, real part in Smith chart and polar format;

**Data2** – zero in rectangular format, imaginary part in Smith chart and polar format.

#### 7.3.1 CSV File Saving/Recalling

To save the trace data, first activate the trace.

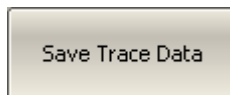

To save the trace data, use the following softkeys:

**Save/Recall > Save Trace Data**

Enter the file name in the dialog that appears.

## 7.4 Trace Data Touchstone File

The Analyzer allows the user to save S-parameters to a Touchstone file. The Touchstone file contains the frequency values and S-parameters. The files of this format are typical for most of circuit simulator programs.

The \*.s2p files are used for saving all the four S-parameters of a 2-port device.

The \*.s1p files are used for saving  $S_{11}$  and  $S_{22}$  parameters of a 1-port device.

Only one (active) trace data are saved to the file.

---

Note	<p>If a channel does not have all the S-parameter traces, only available S-parameter responses will be represented. For example, if one <math>S_{11}</math> trace is enabled, <math>S_{21}</math> response will be represented, and <math>S_{12}</math> and <math>S_{22}</math> will not be represented. The missing S-parameters are displayed as zeroes in the file.</p> <p>If full 2-port calibration is active, all the four S-parameters in a channel are measured, independently of the number of the traces.</p>
------	---

---

The Touchstone file saving function is applied to individual channels. To use this function, first activate the channel.



The Touchstone file contains comments, header, and trace data lines. Comments start from «!» symbol. Header starts from «#» symbol.

The \*.s1p Touchstone file for 1-port measurements:

```
! Comments
# Hz S FMT R Z0
F[0]  {S11}'  {S11}"
F[1]  {S11}'  {S11}"
      ...
F[N]  {S11}'  {S11}"
```

The \*.s2p Touchstone file for 2-port measurements:

```
! Comments
# Hz S FMT R Z0
F[0]  {S11}'  {S11}"  {S21}'  {S21}"  {S12}'  {S12}"  {S22}'  {S22}"
F[1]  {S11}'  {S11}"  {S21}'  {S21}"  {S12}'  {S12}"  {S22}'  {S22}"
      ...
F[N]  {S11}'  {S11}"  {S21}'  {S21}"  {S12}'  {S12}"  {S22}'  {S22}"
```

**Hz** – frequency measurement units (**kHz**, **MHz**, **GHz**)

**FMT** – data format:

- **RI** – real and imaginary parts,
- **MA** – linear magnitude and phase in degrees,
- **DB** – logarithmic magnitude in dB and phase in degrees.



**Z0** – reference impedance value

**F[n]** – frequency at measurement point n

{...}' – {real part (RI) | linear magnitude (MA) | logarithmic magnitude (DB)}

{...}" – {imaginary part (RI) | phase in degrees (MA) | phase in degrees (DB)}

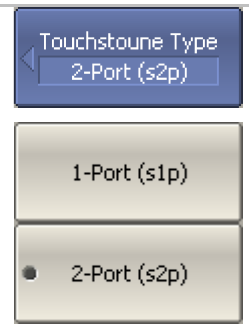
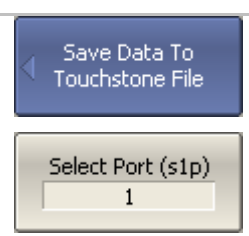
## 7.4.1 Touchstone File Saving/Recalling

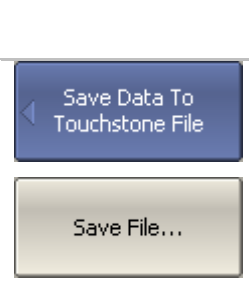
 <p>The screenshot shows a menu titled "Touchstone Type" with a left-pointing arrow. The menu is currently open, showing three options: "2-Port (s2p)" (highlighted in blue), "1-Port (s1p)", and "2-Port (s2p)" (with a radio button selected).</p>	<p>To select the saving type, use the following softkeys:  <b>Save/Recall &gt; Save Data To Touchstone File &gt; Type &gt; 1-Port (s1p)   2-Port (s2p)</b></p>
 <p>The screenshot shows a menu titled "Save Data To Touchstone File" with a left-pointing arrow. The menu is open, showing a sub-menu titled "Select Port (s1p)" with a text input field containing the number "1".</p>	<p>For 1-port saving type select the port number using the following softkeys:  <b>Save/Recall &gt; Save Data To Touchstone File &gt; Select Port (s1p).</b></p>
 <p>The screenshot shows a menu titled "Touchstone Format" with a left-pointing arrow. The menu is open, showing three options: "Real-Imaginary" (highlighted in blue and with a radio button selected), "Magnitude-Angle", and "dB-Angle".</p>	<p>To select the data format, use the following softkeys:  <b>Save/Recall &gt; Save Data To Touchstone File &gt; Format &gt; RI   MA   DB</b></p>
 <p>The screenshot shows a menu titled "Save Data To Touchstone File" with a left-pointing arrow. The menu is open, showing a single option: "Save File...".</p>	<p>To save file to the hard disk, use the following softkeys:  <b>Save/Recall &gt; Save Data To Touchstone File &gt; Save File...</b>  Enter the file name in the dialog that appears.</p>

## 8 SYSTEM SETTINGS

### 8.1 Analyzer Presetting

Analyzer presetting feature allows the user to restore the default settings of the Analyzer.

The default settings of your Analyzer are specified in Appendix 1.



To preset the Analyzer, use the following softkeys:

**System > Preset > OK**

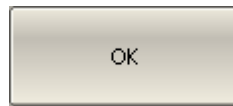

---

### 8.2 Graph Printing

This section describes the print/save procedures for the graph data.

The print function is provided with the preview feature, which allows the user to view the image to be printed on the screen, and/or save it to a file.

You can print out the graphs using three different applications:

- MS Word;
- Image Viewer for Windows;
- Print Wizard of the Analyzer.

---

Note

MS Word application must be installed in Windows system.

---

Note

The Print Wizard requires at least one printer to be installed in Windows.

---

You can select the print color before the image is transferred to the printing application:

- Color (no changes);
- Gray Scale;
- Black & White.

You can invert the image before it is transferred to the printing application.

You can add current date and time before the image is transferred to the printing application.



To print a graph, use the following softkeys:

**System > Print**

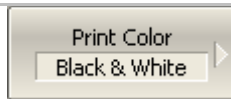

Select the print color, using **Print Color** softkey:

- **Color**
- **Gray Scale**
- **Black & White**

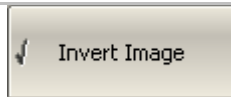

If necessary, invert the image by **Invert Image** softkey.

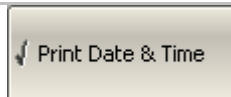

If necessary, select printing of date and time by **Print Date & Time** softkey.

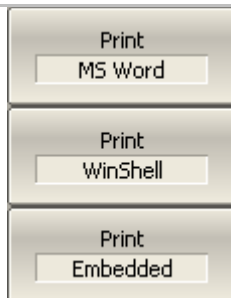

Then select the printing application, using one of the following softkeys:

- **Print: MS Word**
- **Print: Windows**
- **Print: Embedded**

### 8.3 Reference Frequency Oscillator Selection

The Analyzer can operate either with internal or with external reference frequency (10 MHz) oscillator. Initially the Analyzer is set to operation with the internal source of the reference frequency.

You can switch between these two modes in the softkey menu.

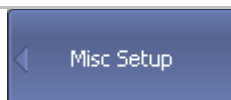

To select the reference frequency oscillator, use the following softkeys:

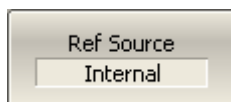

**System > Misc Setup > Ref Source**

## 8.4 System Correction Setting

The Analyzer is supplied from the manufacturer calibrated with the calibration coefficients stored in its non-volatile memory. The factory calibration is used by default for initial correction of the measured S-parameters. Such calibration is referred to as system calibration, and the error correction is referred to as system correction.

The system correction ensures initial values of the measured S-parameters before the Analyzer is calibrated by the user. The system calibration is performed at the plane of the port physical connectors and leaves out of account the cables and other fixture used to connect the DUT. The measurement accuracy of the Analyzer without its calibration with the user setup is not rated.

Normally, the disabling of the system correction **is not required** for a calibration and further measurements.

The system correction can be disabled only in case the user provided a proper calibration for the Analyzer. The measurement accuracy is determined by user calibration and does not depend on the system correction status. The only rule that should be observed is to disable/enable the system correction before the user calibration, so that the calibration and further measurement could be performed under the same conditions.

If the system correction is disabled by the user, this is indicated in the instrument status bar.

---

Note	TRL calibration (Planar 804/1 and S models) is not compatible with system correction. The system correction will be automatically turned off when TRL calibration is performed.
------	---

---

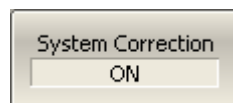

To disable/enable the system correction, use the following softkeys:

**System > Misc Setup > System Correction**

## 8.5 Beeper Setting

The Analyzer features two settings of the beeper, which can be toggled on/off independently from each other:

- *operation complete beeper* – informs the user about normal completion of standard measurements during calibration;
- *warning beeper* – informs the user about an error or a fail limit test result.



To toggle the beeper, use the following softkeys:

**System > Misc Setup > Beeper > Beep Complete**

**System > Misc Setup > Beeper > Beep Warning**

To test the beeper, use the following softkeys:

**System > Misc Setup > Beeper > Test Beep Complete**

**System > Misc Setup > Beeper > Test Beep Warning**

## 8.6 User Interface Setting

The Analyzer enables you to make the following user interface settings:

- Toggle between full screen and window display
- Set color of:
  - Data traces
  - Memory traces
  - Background and grid of graph
  - Background and font of menu bar
- Style and width of:
  - Data traces
  - Memory traces
  - Graph grid
- Font size of:
  - Softkeys
  - Channel window
  - Channel status bar
  - Instrument status bar
- Invert color of graph area
- Hide/show menu bar
- Hide/show stimulus graticule (X axis)
- Set response graticule mode (Y axis)
  - off
  - on for active trace
  - on for all traces

---

**Note**

The user interface settings are automatically saved and will restore when you next time turn the Analyzer on. No particular saving procedure is required. There is a button for restoration of the default factory settings for the user interface.

---

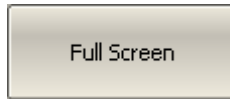
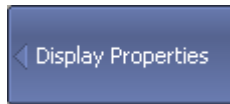

To toggle between full screen and window display, use the following softkeys:

**Display > Properties > Full Screen**

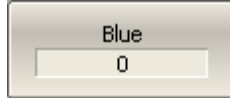
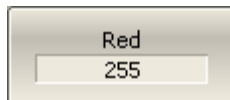
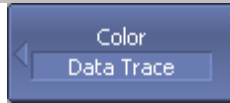

To change the color of the active data trace, use the following softkeys:

**Display > Properties > Color > Data Trace**

Then select the rate (from 0 to 255) of color components.

The changes made to the color of the active data traces will affect all the traces with the same number in other channels.

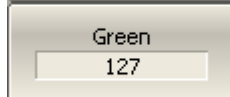
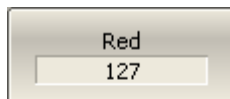
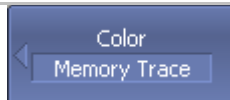

To change the color of the active memory trace, use the following softkeys:

**Display > Properties > Color > Memory Trace**

Then select the rate (from 0 to 255) of color components.

The changes made to the color of the active memory traces will affect all the traces with the same number in other channels.

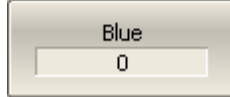
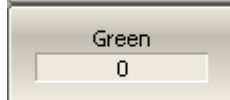
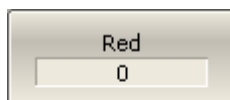
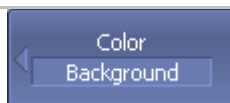

To change the color of the background of the graph, use the following softkeys:

**Display > Properties > Color > Background**

Then select the rate (from 0 to 255) of color components.



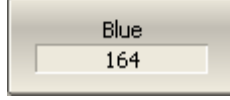
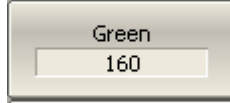
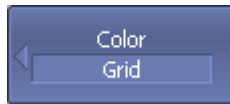

To change the color of the grid of the graph, use the following softkeys:

**Display > Properties > Color > Grid**

Then select the rate (from 0 to 255) of color components.

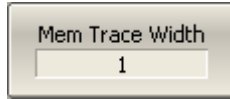
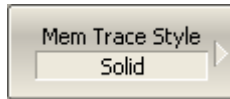
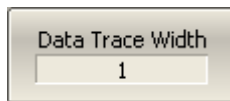
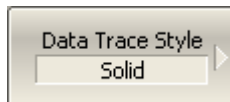
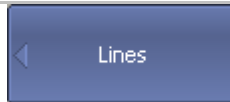

To change the style and width of a data trace, use the following softkeys:

**Display > Properties > Lines > Data Trace Style**

**Display > Properties > Lines > Data Trace Width**

To change the style and width of a memory trace, use the following softkeys:

**Display > Properties > Lines > Mem Trace Style**

**Display > Properties > Lines > Mem Trace Width**

To change the grid style, the following softkeys:

**Display > Properties > Lines > Grid Style**

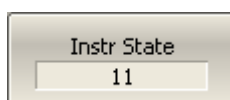
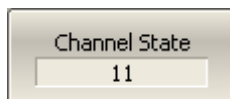

To change the font size on the softkeys, in the channel window, in the channel status bar, or the instrument status bar, use the following softkeys:

**Display > Properties > Font Size > Softkeys**

**Display > Properties > Font Size > Window Channel**

**Display > Properties > Font Size > Channel State**

**Display > Properties > Font Size > Instr State**

Then select the font size from 10 to 13.

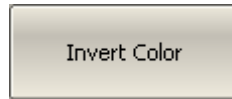
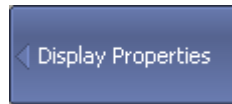

To invert the color of the graph area, use the following softkeys:

**Display > Properties > Invert Color**

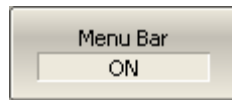
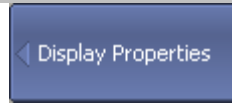

To hide/show the menu bar, use the following softkeys:

**Display > Properties > Menu Bar**

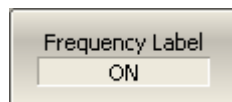
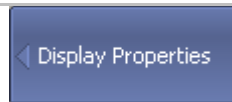

To hide/show stimulus graticule (X axis), use the following softkeys:

**Display > Properties > Frequency Label**

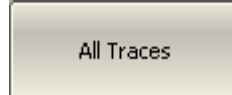
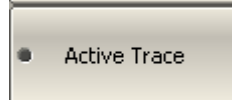
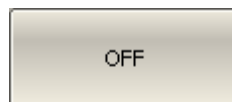
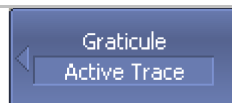

To set the response graticule label mode (Y axis), use the following softkeys:

**Display > Properties > Graticule Label>**

**OFF | Active Trace | All Traces**

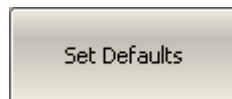
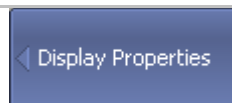

To restore the default factory settings, use the following softkeys:

**Display > Properties > Set Defaults**

## 8.7 Screen Update Setting

Screen updating can be disabled to reduce the sweep time. This function can be useful during remote control over the Analyzer via COM/DCOM interfaces.

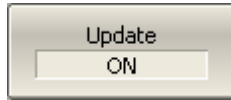
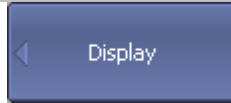

To disable the screen updating, use the following softkeys:

**Display > Update**

---

### Note

If the screen updating is off, this will be indicated in the instrument status bar **Update Off**.

---

## 8.8 Power Meter Setting

An external power meter can be connected to the Analyzer to perform power calibration of the test ports. Connect the power meter to PC directly to USB port or via USB/GPIB adapter. Then install the power meter software. The list of the power meters supported by the Analyzer is shown in Table 29.

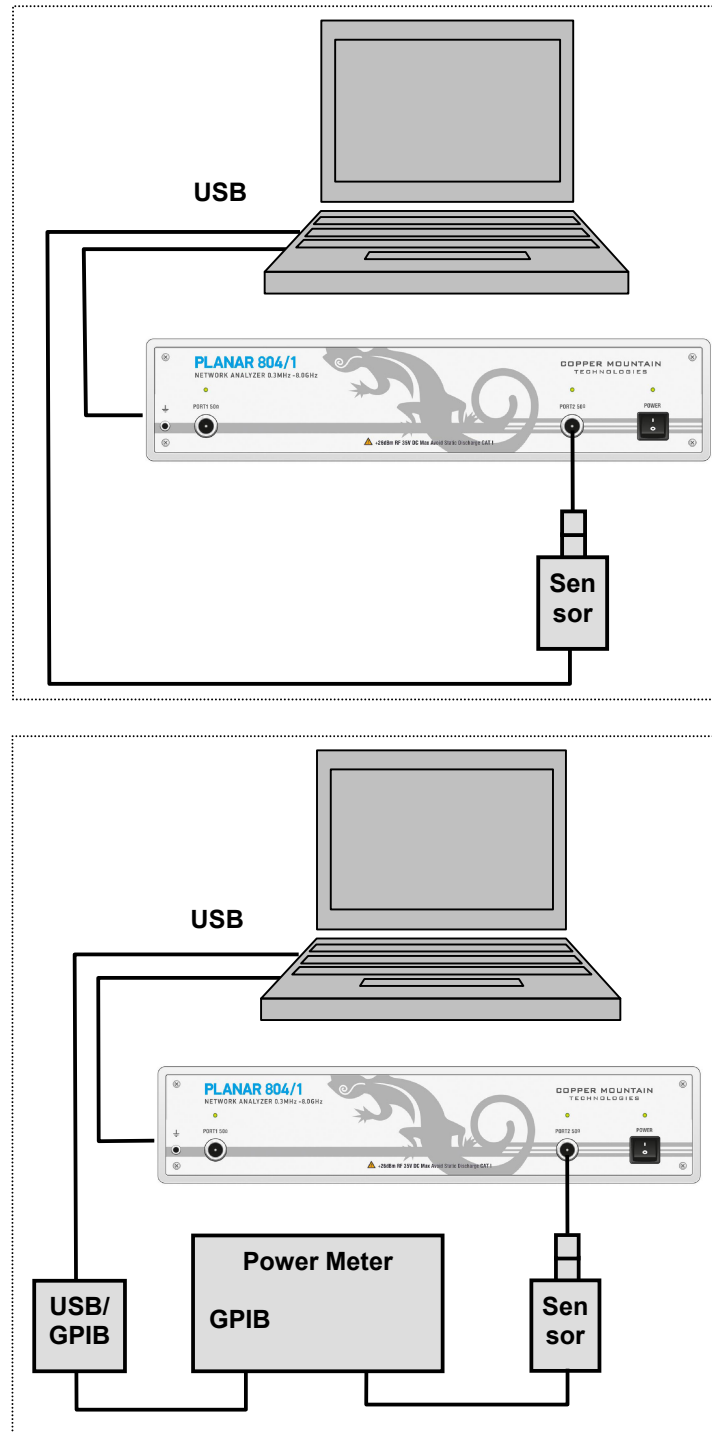
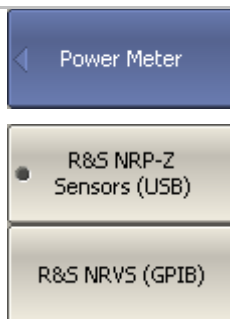

Figure 75 Power meter setup example

Table 29 Supported power meters

Power Meter	Name in Analyzer Program	USB Connection Type	Additional Software
Rohde&Schwarz NRP-Z series Sensors (without Power Meter)  NRP-Z51 (recommended)	<b>R&amp;S NRP-Z sensors</b>	R&S NRP-Z4 Adapter	<ul style="list-style-type: none"> <li>■ Rohde&amp;Schwarz NRP-Toolkit (NRP-Toolkit)</li> <li>■ Rohde&amp;Schwarz RSNRPZ Instrument driver (rsnrpz_vxipnp)</li> </ul>
Rohde&Schwarz NRVS Power Meter and NRV -Z51, -Z4 , and -Z3 (75 Ohm) Sensors	<b>R&amp;S NRVS</b>	GPIB/USB Adapter	<ul style="list-style-type: none"> <li>■ GPIB/USB Adapter driver</li> <li>■ VISA visa32.dll Library</li> </ul>



To select the power meter, use the following softkeys:  
**System > Misc Setup > Power Meter Setup > Power Meter > R&S NRP-Z sensors (USB) | R&S NRVS (GPIB)**



If the power meter has GPIB interface, set the GPIB board address and the power meter address in the bus, using the following softkeys:

**System > Misc Setup > Power Meter Setup > GPIB Board**

**System > Misc Setup > Power Meter Setup > GPIB Address**

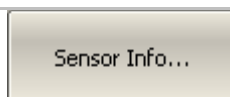

**Sensor Info...** softkey checks the connection and settings of the power meter. It provides sensor type, if the communication between the Analyzer and the power meter has been successfully established.

## 8.9 Stimulus Frequency Adjustment (Planar 804/1 and S models)

This function provides fine adjustment of the stimulus frequency by means of an external frequency meter. By setting the stimulus frequency adjustment coefficient from -128 to +127, you can perform relative adjustment of the frequency within  $\pm 0.001\%$  (typical value). This setting will be saved in the nonvolatile memory of the Analyzer. The function adjusts the frequency of the internal reference frequency oscillator, so to adjust the frequency over all the operating frequency range, it is sufficient to perform the adjustment in one frequency point.

To adjust the stimulus frequency, proceed as follows:

Switch the Analyzer on and warm it up to operating temperature for the period of time stated in its specifications;

Connect the frequency meter to the output connector of the internal reference frequency (10 MHz) oscillator or to one of the Analyzer test ports;

If you connect the frequency meter to a test port of the Analyzer, set this test port to the CW-frequency output operation.

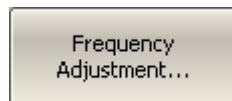
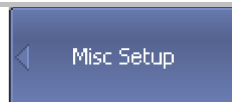

To access the stimulus frequency adjustment function, use the following softkeys:

**System > Misc Setup > Frequency Adjustment...**

In the pop-up dialog, set the stimulus frequency adjustment coefficient, which ensures the value measured by the frequency meter being closest to the output frequency of the Analyzer. Save this coefficient to the nonvolatile memory by clicking **Save** softkey.

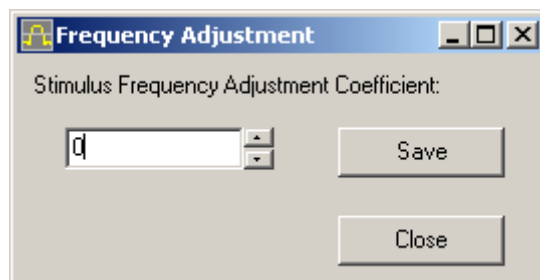

## 8.10 Port Overload Indication (Planar 804/1 and S models)

Port overload indication function is used to inform the user when the input power exceeds the capacity of the port such that the measurement accuracy does not meet the instrument's specification. Port overload can occur when testing active devices. When testing passive devices overload cannot occur.

Overload indication is a message in the status bar of the instrument: "Port n overload!", where n - number of the port. The message has a red background color.

When the overload condition is resolved, the overload indication disappears automatically after 2 seconds. In the event of a transient overload, the 2 second persistence enables the user to take notice.

Display of the overload warning cannot be disabled by the user.

## 8.11 Power Trip Function (Planar 804/1 and S models)

Power Trip function is a safety feature to protect analyzer's port from over-input. The Function disables the stimulus signal when the port safety power level is exceeded. The safety threshold used by this function is above the overload threshold, as described in the preceding paragraph.

Excessive port power level may occur when testing active devices.

When triggered, this function disables the stimulus signal and indicates the message in the status bar of the instrument: "Port n Power Trip at Overload!", where n - number of the port. Message has a red background color.

After the overload trips, the user must resolve the issue causing the overload, and then manually re-enable the stimulus via the submenu **Stimulus > Power > RF output [On]**.

The power trip function can be enabled or disabled by the user. By default, it is disabled. The ON / OFF state of this function is retained in subsequent sessions and does not depend on the **Preset** button.

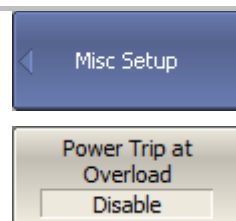

To enable the power trip function, use the following softkeys:

**System > Misc Setup > Power Trip at Overload**

## 9 MAINTENANCE AND STORAGE

### 9.1 Maintenance Procedures

This section describes the guidelines and procedures of maintenance, which will ensure fault-free operation of your Analyzer.

The maintenance of the Analyzer consists in cleaning of the instrument, factory calibrations, and regular performance tests.

#### 9.1.1 Instrument Cleaning

This section provides the cleaning instructions required for maintaining the proper operation of your Analyzer.

To remove contamination from parts other than test ports and any connectors of the Analyzer, wipe them gently with a soft cloth that is dry or wetted with a small amount of water and wrung tightly.

It is essential to keep the test ports always clean as any dust or stains on them can significantly affect the measurement capabilities of the instrument. To clean the test ports (as well as other connectors of the Analyzer), use the following procedure:

- using compressed air remove or loosen the contamination particles;
- clean the connectors using a lint-free cleaning cloth wetted with a small amount of ethanol and isopropyl alcohol (when cleaning a female connector, avoid snagging the cloth on the center conductor contact fingers by using short strokes);
- dry the connector with low-pressure compressed air.

Always completely dry a connector before using it.

Never use water or abrasives for cleaning any connectors of the Analyzer. Do not allow contact of alcohol to the surface of the insulators of the connectors.

When connecting male-female coaxial connectors always use a calibrated torque wrench.

---

**WARNING**

**Never perform cleaning of the instrument if the power cable is connected to the power outlet.**

**Never clean the internal components of the instrument.**

---



### 9.1.2 Factory Calibration

Factory calibration is a regular calibration performed by the manufacturer or an authorized service center. We recommend you to send your Analyzer for factory calibration every three years.

### 9.1.3 Performance Test

Performance test is the procedure of the Analyzer performance verification by confirming that the behavior of the instrument meets the published specifications.

Performance test of the Analyzer should be performed in accordance with *Performance Test Instructions*.

The Analyzer software is provided with **System > Performance Test** submenu for automatic verification execution.

Performance test period is one year.

## 9.2 Storage Instructions

Before first use store your Analyzer in the factory package at environment temperature from 0 to +40 °C and relative humidity up to 80% (at 25 °C).

After you have removed the factory package store the Analyzer at environment temperature from +10 to +35 °C and relative humidity up to 80% (at 25 °C).

Ensure to keep the storage facilities free from dust, fumes of acids and alkaline, volatile gases, and other chemicals, which can cause corrosion.

## 10 WARRANTY INFORMATION

1. The manufacturer warrants the Network Analyzer to conform to the specifications of this Manual when used in accordance with the regulations of operation detailed in this Manual.

2. The manufacturer will repair or replace without charge, at its option, any Analyzer found defective in manufacture within the warranty period, which is twelve (12) months from the date of purchase. Should the user fail to submit the warranty card appropriately certified by the seller with its stamp and date of purchase the warranty period will be determined by the date of manufacture.

3. The warranty is considered void if:

a) the defect or damage is caused by improper storage, misuse, neglect, inadequate maintenance, or accident;

b) the product is tampered with, modified or repaired by an unauthorized party;

c) the product's seals are tampered with;

d) the product has mechanical damage.

4. The batteries are not included or covered by this warranty.



5. Transport risks and costs to and from the manufacturer or the authorized service centers are sustained by the buyer.

6. The manufacturer is not liable for direct or indirect damage of any kind to people or goods caused by the use of the product and/or suspension of use due to eventual repairs.

7. When returning the faulty product please include the accurate details of this product and clear description of the fault. The manufacturer reserves the right to check the product in its laboratories to verify the foundation of the claim.

## Appendix 1 – Default Settings Table

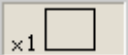
Default values defined in the process of the initial factory setup.

Parameter Description	Default Setting	Parameter Setting Object
Data Saving Type	State and Calibration	Analyzer
Touchstone Data Format	Real-Imaginary	Analyzer
Allocation of Channels		Analyzer
Active Channel Number	1	Analyzer
Marker Value Identification Capacity (Stimulus)	7 digits	Analyzer
Marker Value Identification Capacity (Response)	4 digits	Analyzer
Marker Table	OFF	Analyzer
Reference Frequency Source	Internal	Analyzer
Trigger Signal Source	Internal	Analyzer
Reference Channel Error Correction	ON	Analyzer
System Correction	ON	Analyzer
Allocation of Traces		Channel
Vertical Divisions	10	Channel
Channel Title Bar	OFF	Channel
Channel Title	Empty	Channel
«FAIL» Label Display (Limit Test)	OFF	Channel
Segment Sweep Frequency Axis Display	Frequency Order	Channel
Traces per Channel	1	Channel
Active Trace Number	1	Channel
Marker Coupling	ON	Channel
Sweep Type	Linear Frequency	Channel
Number of Sweep Points	201	Channel
Stimulus Start Frequency	Instrument min.	Channel
Stimulus Stop Frequency	Instrument max.	Channel
Stimulus CW Frequency	Instrument min.	Channel

Stimulus Start Power Level	Instrument min.	Channel
Stimulus Stop Power Level	Instrument max.	Channel
Stimulus Power Level	0 dBm	Channel
Stimulus Power Slope	0 dBm	Channel
Stimulus IF Bandwidth	10 kHz	Channel
Sweep Measurement Delay	0 sec.	Channel
Sweep Range Setting	Start / Stop	Channel
Number of Segments	1	Channel
Points per Segment	2	Channel
Segment Start Frequency	Instrument min.	Channel
Segment Stop Frequency	Instrument min.	Channel
Segment Sweep Power Level	0 dBm	Channel
Segment Sweep IF Bandwidth	10 kHz	Channel
Segment Sweep Measurement Delay	0 sec.	Channel
Segment Sweep Power Level (Table Display)	OFF	Channel
Segment Sweep IF Bandwidth (Table Display)	OFF	Channel
Segment Sweep Measurement Delay (Table Display)	OFF	Channel
Segment Sweep Range Setting	Start / Stop	Channel
Averaging	OFF	Channel
Averaging Factor	10	Channel
Trigger Mode	Continuous	Channel
Table of Calibration Coefficients	Empty	Channel
Error Correction	OFF	Channel
Port Z Conversion	OFF	Channel
Port 1 Simulated Impedance	Instrument Nominal	Channel
Port 2 Simulated Impedance	Instrument Nominal	Channel
Port 1 De-embedding	OFF	Channel
Port 2 De-embedding	OFF	Channel
Port 1 De-embedding S-parameter File	Empty	Channel
Port 2 De-embedding S-parameter File	Empty	Channel
Port 1 Embedding	OFF	Channel

Port 2 Embedding	OFF	Channel
Port 1 Embedding User File	Empty	Channel
Port 2 Embedding User File	Empty	Channel
Measurement Parameter	$S_{11}$	Trace
Trace Scale	10 dB / Div.	Trace
Reference Level Value	0 dB	Trace
Reference Level Position	5 Div.	Trace
Data Math	OFF	Trace
Phase Offset	0°	Trace
Electrical Delay	0 sec.	Trace
S-parameter Conversion	OFF	Trace
S-parameter Conversion Function	Z: Reflection	Trace
Trace Display Format	Logarithmic Magnitude (dB)	Trace
Time Domain Transformation	OFF	Trace
Time Domain Transformation Start	-10 nsec.	Trace
Time Domain Transformation Stop	10 nsec.	Trace
Time Domain Kaiser-Beta	6	Trace
Time Domain Transformation Type	Bandpass	Trace
Time Domain Gate	ON	Trace
Time Domain Gate Start	-10 ns	Trace
Time Domain Gate Stop	10 ns	Trace
Time Domain Gate Type	Bandpass	Trace
Time Domain Gate Shape	Normal	Trace
Smoothing	OFF	Trace
Smoothing Aperture	1%	Trace
Trace Display Mode	Data	Trace
Limit Test	OFF	Trace
Limit Line Display	OFF	Trace
Defined Limit Lines	Empty	Trace
Number of Markers	0	Trace
Marker Position	Instrument min.	Trace
Marker Search	Maximum	Trace
Marker Tracking	OFF	Trace

Marker Search Target	0 dB	Trace
Marker Search Target Transition	Both	Trace
Marker Search Peak Polarity	Positive	Trace
Marker Search Peak Excursion	3 dB	Trace
Bandwidth Parameter Search	OFF	Trace
Marker Search Bandwidth Value	-3 dB	Trace
Marker Search Range	OFF	Trace
Marker Search Start	0	Trace
Marker Search Stop	0	Trace