

PLANAR R54 Vector Reflectometer

Operating Manual



Revision: 2.1
December 2013



TABLE OF CONTENTS

INTRODUCTION	7
SAFETY INSTRUCTIONS	8
1 GENERAL OVERVIEW	9
1.1 Description.....	9
1.2 Specifications.....	9
1.2.1 Basic Specifications.....	9
1.2.2 Supplemental Specifications	11
1.2.3 Measurement Capabilities	11
1.3 Ordering Information.....	16
1.3.1 Standard Accessories.....	16
1.4 Principle of Operation.....	16
2 PREPARATION FOR USE	18
2.1 General Information.....	18
2.2 Software Installation.....	19
2.3 Top Panel.....	20
2.4 Test Port.....	20
2.5 Mini B USB Port	20
3 GETTING STARTED	21
3.1 Reflectometer Preparation for Reflection Measurement	21
3.2 Reflectometer Presetting.....	22
3.3 Stimulus Setting.....	22
3.4 IF Bandwidth Setting.....	23
3.5 Number of Traces, Measured Parameter and Display Format Setting.....	24
3.6 Trace Scale Setting	25
3.7 Reflectometer Calibration for Reflection Coefficient Measurement	26
3.8 SWR and Reflection Coefficient Phase Analysis Using Markers	28
4 MEASUREMENT CONDITIONS SETTING	30
4.1 Screen Layout and Functions.....	30
4.1.1 Softkey Menu Bars	30
4.1.2 Instrument Status Bar	31
4.2 Channel Window Layout and Functions	32
4.2.1 Channel Title Bar	33
4.2.2 Trace Status Field.....	33
4.2.3 Graph Area	36
4.2.4 Markers.....	37
4.2.5 Channel Status Bar	37
4.3 Quick Channel Setting Using Mouse	39

4.3.1	Active Channel Selection	39
4.3.2	Active Trace Selection	39
4.3.3	Display Format Setting.....	40
4.3.4	Trace Scale Setting.....	40
4.3.5	Reference Level Setting	40
4.3.6	Marker Stimulus Value Setting	41
4.3.7	Switching between Start/Center and Stop/Span Modes	41
4.3.8	Start/Center Value Setting.....	42
4.3.9	Stop/Span Value Setting.....	42
4.3.10	Sweep Points Number Setting	42
4.3.11	IF Bandwidth Setting.....	44
4.3.12	Power Level Setting	44
4.4	Channel and Trace Display Setting	44
4.4.1	Setting the Number of Channel Windows.....	44
4.4.2	Channel Activating.....	45
4.4.3	Active Channel Window Maximizing.....	45
4.4.4	Number of Traces Setting.....	46
4.4.5	Active Trace Selection	47
4.5	Measurement Parameters Setting.....	49
4.5.1	S-Parameters.....	49
4.5.2	Trace Format	50
4.5.3	Rectangular Format	50
4.5.4	Smith Chart Format	52
4.5.5	Trace Format Setting	53
4.6	Scale Setting	54
4.6.1	Rectangular Scale.....	54
4.6.2	Rectangular Scale Setting.....	54
4.6.3	Circular Scale	55
4.6.4	Circular Scale Setting	56
4.6.5	Automatic Scaling	56
4.6.6	Reference Level Automatic Selection	56
4.6.7	Electrical Delay Setting.....	57
4.6.8	Phase Offset Setting	58
4.7	Stimulus Setting.....	58
4.7.1	Sweep Type Setting.....	59
4.7.2	Sweep Span Setting.....	60
4.7.3	Sweep Points Setting.....	61
4.7.4	Distance to Fault Maximum Value Setting	61
4.7.5	Stimulus Power Setting	63
4.7.6	Segment Table Editing	63
4.8	Trigger Setting.....	65
4.9	Measurement Optimizing	66
4.9.1	IF Bandwidth Setting.....	66
4.9.2	Averaging Setting.....	67
4.9.3	Smoothing Setting.....	67
4.9.4	Max Hold Function	68
4.10	Cable Specifications.....	69
4.10.1	Selecting the type of cable.....	69
4.10.2	Manually specify Velocity Factor and Cable Loss.....	70
4.10.3	Editing table of cables	70
5	CALIBRATION AND CALIBRATION KIT	71

5.1	General Information.....	71
5.1.1	Measurement Errors	71
5.1.2	Systematic Errors.....	71
5.1.2.1	Directivity Error	72
5.1.2.2	Source Match Error	72
5.1.2.3	Reflection Tracking Error	72
5.1.3	Error Modeling	72
5.1.3.1	One-Port Error Model	72
5.1.4	Reflectometer Test Port Defining.....	73
5.1.5	Calibration Steps	74
5.1.6	Calibration Methods	74
5.1.6.1	Normalization.....	76
5.1.6.2	Expanded Normalization.....	76
5.1.6.3	Full One-Port Calibration.....	76
5.1.7	Calibration Standards and Calibration Kits	76
5.1.7.1	Types of Calibration Standards	77
5.1.7.2	Calibration Standard Model	77
5.2	Calibration Procedures.....	80
5.2.1	Calibration Kit Selection	80
5.2.2	Reflection Normalization	82
5.2.3	Full One-Port Calibration	84
5.2.4	Error Correction Disabling.....	85
5.2.5	Error Correction Status.....	86
5.2.6	System Impedance Z_0	86
5.2.7	Port Extension	86
5.2.8	Auto Port Extension	88
5.3	Calibration Kit Management	89
5.3.1	Calibration Kit Selection for Editing.....	89
5.3.2	Calibration Kit Label Editing	90
5.3.3	Predefined Calibration Kit Restoration	91
5.3.4	Calibration Standard Editing	92
5.3.5	Calibration Standard Defining by S-Parameter File.....	94
5.4	Automatic Calibration Module	95
5.4.1	Automatic Calibration Module Features	96
5.4.2	Automatic Calibration Procedure	96
6	MEASUREMENT DATA ANALYSIS	98
6.1	Markers	98
6.1.1	Marker Adding	99
6.1.2	Marker Deleting.....	99
6.1.3	Marker Stimulus Value Setting	100
6.1.4	Marker Activating	101
6.1.5	Reference Marker Feature	101
6.1.6	Marker Properties	103
6.1.6.1	Marker Coupling Feature	103
6.1.6.2	Marker Value Indication Capacity	104
6.1.6.3	Multi Marker Data Display	104
6.1.6.4	Marker Data Alignment	105
6.1.7	Marker Position Search Functions.....	106
6.1.7.1	Search for Maximum and Minimum	106
6.1.7.2	Search for Peak	107
6.1.7.3	Search for Target Level.....	110
6.1.7.4	Search Tracking	111
6.1.7.5	Search Range.....	112

6.1.8	Marker Math Functions	112
6.1.8.1	Trace Statistics	113
6.1.8.2	Flatness.....	115
6.2	Memory Trace Function	116
6.2.1	Saving Trace into Memory	117
6.2.2	Memory Trace Deleting	117
6.2.3	Memory Trace Math.....	118
6.3	Fixture Simulation	120
6.3.1	Port Z Conversion	120
6.3.2	De-embedding	121
6.3.3	Embedding.....	123
6.4	Time Domain Transformation	124
6.4.1	Time Domain Transformation Activating	125
6.4.2	Time Domain Transformation Span	125
6.4.3	Time Domain Transformation Window Shape Setting	126
6.5	Time Domain Gating	126
6.5.1	Time Domain Gate Activating	128
6.5.2	Time Domain Gate Span	128
6.5.3	Time Domain Gate Type.....	129
6.5.4	Time Domain Gate Shape Setting	130
6.6	S-Parameter Conversion	130
6.7	Limit Test.....	131
6.7.1	Limit Line Editing	132
6.7.2	Limit Test Enabling/Disabling	134
6.7.3	Limit Test Display Management	134
6.7.4	Limit Line Offset.....	135
6.8	Ripple Limit Test.....	135
6.8.1	Ripple Limit Editing.....	136
6.8.2	Ripple Limit Enabling/Disabling	137
6.8.3	Ripple Limit Test Display Management	138
7	CABLE LOSS MEASUREMENT.....	139
7.1	Cable Loss Measurement Algorithm	139
8	REFLECTOMETER DATA OUTPUT	140
8.1	Reflectometer State.....	140
8.1.1	Reflectometer State Saving	141
8.1.2	Reflectometer State Recalling	142
8.1.3	Autosave and Autorecall State of Reflectometer.....	143
8.2	Channel State	144
8.2.1	Channel State Saving.....	144
8.2.2	Channel State Recalling	145
8.3	Trace Data CSV File.....	146
8.3.1	CSV File Saving.....	146
8.4	Trace Data Touchstone File.....	147
8.4.1	Touchstone File Saving	148
8.4.2	Touchstone File Recalling.....	150
8.5	Graph Printing	151
8.5.1	Graph Printing Procedure	151
8.5.2	Quick saving program screen shot.....	152

9	SYSTEM SETTINGS	152
9.1	Reflectometer Presetting.....	152
9.2	Program Exit.....	153
9.3	Reflectometer System Data	153
9.4	System Correction Setting	154
9.5	User Interface Setting	155
10	SPECIFICS OF WORKING WITH TWO DEVICES PLANAR R54.....	156
10.1	Installation of additional software.....	156
10.2	Connecting devices to a USB port	156
10.3	Frequency tuning of the internal generators.....	156
10.3.1	Manual frequency tuning.....	157
10.3.2	Automatic frequency tuning	157
10.4	The features of calibration of instruments.....	158
10.4.1	Port selection	159
10.4.2	Scalar Transmission Normalization.....	159
10.4.3	Expanded Transmission Normalization.....	160
10.5	Selection of the measured S-parameters	161
11	MAINTENANCE AND STORAGE	162
11.1	Maintenance Procedures	162
11.1.1	Instrument Cleaning	162
11.1.2	Factory Calibration.....	162
11.2	Storage Instructions.....	163
12	WARRANTY INFORMATION	164
	Appendix 1 — Default Settings Table	165

INTRODUCTION

This Operating Manual represents design, specifications, overview of functions, and detailed operation procedure of PLANAR R54 Vector Reflectometer, to ensure effective and safe use of the technical capabilities of the instrument by the user.

Vector Reflectometer operation and maintenance should be performed by qualified engineers with initial experience in operating of microwave circuits and PC.

The following abbreviations are used in this Manual:

PC – Personal Computer

DUT – Device Under Test

IF – Intermediate Frequency

CW – Continuous Wave

SWR – Standing Wave Ratio

SAFETY INSTRUCTIONS

Carefully read through the following safety instructions before putting the Reflectometer into operation. Observe all the precautions and warnings provided in this Manual for all the phases of operation, service, and repair of the Reflectometer.

The Reflectometer must be used only by skilled and specialized staff or thoroughly trained personnel with the required skills and knowledge of safety precautions.

PLANAR R54 complies with INSTALLATION CATEGORY I as well as POLLUTION DEGREE 2 in IEC61010–1.

PLANAR R54 is MEASUREMENT CATEGORY I (CAT I). Do not use for CAT II, III, or IV.

PLANAR R54 is tested in stand-alone condition or in combination with the accessories supplied by PLANAR against the requirement of the standards described in the Declaration of Conformity. If it is used as a system component, compliance of related regulations and safety requirements are to be confirmed by the builder of the system.

Never operate the Reflectometer in the environment containing inflammable gasses or fumes.

Operators must not remove the cover or part of the housing. The Reflectometer must not be repaired by the operator. Component replacement or internal adjustment must be performed by qualified maintenance personnel only.

Electrostatic discharge can damage your Reflectometer when connected or disconnected from the DUT. Static charge can build up on your body and damage the sensitive circuits of internal components of both the Reflectometer and the DUT. To avoid damage from electric discharge, observe the following:

- Always use a desktop anti static mat under the DUT.
- Always wear a grounding wrist strap connected to the desktop anti static mat via daisy-chained 1 M Ω resistor.
- Connect the PC and the body of the DUT to protective grounding before you start operation.

CAUTION

This sign denotes a hazard. It calls attention to a procedure, practice, or condition that, if not correctly performed or adhered to, could result in damage to or destruction of part or all of the instrument.

Note

This sign denotes important information. It calls attention to a procedure, practice, or condition that is essential for the user to understand.

1 GENERAL OVERVIEW

1.1 Description

PLANAR R54 Vector Reflectometer is designed for use in the process of development, adjustment and testing of antenna-feeder devices in industrial and laboratory facilities, as well as in field, including operation as a component of an automated measurement system. PLANAR R54 Vector Reflectometer is designed for operation with external PC, which is not supplied with it.

1.2 Specifications

1.2.1 Basic Specifications

Table 1.1 Basic Specifications

1	2
Frequency range	85 MHz to 4.2 GHz (5.4 GHz, typ.) ¹
Full CW frequency accuracy	$\pm 6 \times 10^{-6}$
Output power: High level Low level	-10 dBm (typ.) -30 dBm (typ.)
Magnitude reflection measurement accuracy ² , if $ S_{11} $ value is as follows: -15 dB to 0 dB -25 dB to -15 dB -35 dB to -25 dB	0.4 dB 1.5 dB 4.0 dB

¹ The specifications within the frequency range from 4.2 GHz to 5.4 GHz are not guaranteed.

² The specifications of the Reflectometer apply over the temperature range of $23^{\circ}\text{C} \pm 5^{\circ}\text{C}$ after 5 minutes of warming-up, with less than 1°C deviation from the full one-port calibration temperature at high output power and IF bandwidth 100 Hz.

Table 1.1 (continued)

1	2
Phase reflection measurement accuracy ² , if $ S_{11} $ value is as follows: -15 dB to 0 dB -25 dB to -15 dB -35 dB to -25 dB	4° 7° 22°
Magnitude transmission measurement accuracy ³ , if $ S_{21} $ values are as follows -40 dB to 0 dB	1.0 dB
Dynamic range measurement $ S_{21} $ ³ (IF bandwidth 1 kHz)	87 dB, typ.
Trace noise magnitude (high output power, IF bandwidth 1 kHz)	0.015 dB rms
Uncorrected directivity	18 dB
Uncorrected source match	-18 dB
External PC system requirements: - operating system - CPU frequency - RAM memory	WINDOWS XP / VISTA / 7 1 GHz 512 MB
Connection to PC: - Connector type - Interface	mini USB B USB 2.0
Power consumption	2 W
Dimensions LxWxH	117 x 39 x 19 mm
Weight	0.25 kg
Operating conditions: - environmental temperature - humidity at 25 °C - atmospheric pressure	-10 °C to 50 °C 90% 84 to 106.7 kPa

³ measurement $|S_{21}|$ using two Reflectometers connected to the same USB hub, applies over the temperature range of 23°C ± 5°C after 5 minutes of warming-up, with less than 1°C deviation from the calibration temperature at high output power and IF bandwidth 1 kHz.

1.2.2 Supplemental Specifications

Frequency setting resolution 10 Hz.

Number of measurement points 2 to 16001

Measurement bandwidths 100 Hz to 30 kHz (with 1/3 step)

Measurement time per test point 200 μ s.

Test port damage level +23 dBm.

Test port damage DC voltage 50 V.

Interference immunity +17 dBm.

Effective directivity:

85 MHz to 4 GHz: 45 dB

4 GHz to 4.2 GHz: 40 dB

Factory-calibrated system data

effective directivity:

85 MHz to 4 GHz: 36 dB

4 GHz to 4.2 GHz: 32 dB

Effective source match:

85 MHz to 4 GHz: -40 dB

4 GHz to 4.2 GHz: -35 dB

Temperature dependence (per one degree of temperature variation) 0.02 dB

Warm-up time 5 min.

1.2.3 Measurement Capabilities

Measured parameters	S_{11} , cable loss, S_{11} , $ S_{21} $, $ S_{12} $, S_{22} - using two Reflectometers.
---------------------	---

Number of measurement channels	Up to 4 logical channels. Each logical channel is represented on the screen as an individual channel window. A logical channel is defined by such stimulus signal settings as frequency range, number of test points, etc.
--------------------------------	--

Data traces	Up to 4 data traces can be displayed in each channel window. A data trace represents one of such parameters of the DUT as magnitude and phase of S_{11} , DTF, cable loss.
Memory traces	Each of the 4 data traces can be saved into memory for further comparison with the current values.
Data display formats	SWR, Return loss, Cable loss, Phase, Expanded phase, Smith chart diagram, DTF SWR, DTF Return loss, Group delay.

Sweep setup features

Sweep type	Linear frequency sweep, logarithmic frequency sweep, and segment frequency sweep.
Measured points per sweep	Set by user from 2 to 16,001.
Segment sweep	A frequency sweep within several user-defined segments. Frequency range, number of sweep points, IF bandwidth and measurement delay should be set for each segment.
Power settings	Two modes of output power level. High level: -10 dBm Low level: -30 dBm
Sweep trigger	Trigger modes: continuous, single, hold.

Trace display functions

Trace type	Data trace, memory trace.
Trace math	Data trace modification by math operations: addition, subtraction, multiplication or division of measured complex values and memory data.
Autoscaling	Automatic selection of scale division and reference level value to have the trace most effectively displayed.
Electrical delay	Calibration plane moving to compensate for the delay in the test setup. Compensation for electrical delay in a DUT during measurements of deviation from linear phase.
Phase offset	Phase offset defined in degrees.

Accuracy enhancement

Calibration	Calibration of a test setup (which includes the Reflectometer and adapter) significantly increases the accuracy of measurements. Calibration allows for correction of the errors caused by imperfections in the measurement system: system directivity, source match, and tracking.
Calibration methods	The following calibration methods are available: <ul style="list-style-type: none"> • reflection normalization; • full one-port calibration.
Reflection normalization	The simplest calibration method.
Full one-port calibration	Method of calibration that ensures high accuracy.
Factory calibration	The factory calibration of the Reflectometer allows performing measurements without additional calibration and reduces the measurement error after reflection normalization.
Mechanical calibration kits	The user can select one of the predefined calibration kits of various manufacturers or define own calibration kits.
Electronic calibration modules	Electronic calibration modules manufactured by PLANAR make the Reflectometer calibration faster and easier than traditional mechanical calibration.
Defining of calibration standards	Different methods of calibration standard defining are available: <ul style="list-style-type: none"> • standard defining by polynomial model • standard defining by data (S-parameters).
Error correction interpolation	When the user changes such settings as start/stop frequencies and number of sweep points, compared to the settings of calibration, interpolation or extrapolation of the calibration coefficients will be applied.

Marker functions

Data markers	Up to 16 markers for each trace. A marker indicates stimulus value and the measured value in a given point of the trace.
Reference marker	Enables indication of any maker values as relative to the reference marker.
Marker search	Search for max, min, peak, or target values on a trace.
Marker search additional features	User-definable search range. Functions of specific condition tracking or single operation search.
Setting parameters by markers	Setting of start, stop and center frequencies by the stimulus value of the marker and setting of reference level by the response value of the marker.
Marker math functions	Statistics, bandwidth, flatness, RF filter.
Statistics	Calculation and display of mean, standard deviation and peak-to-peak in a frequency range limited by two markers on a trace.
Bandwidth	Determines bandwidth between cutoff frequency points for an active marker or absolute maximum. The bandwidth value, center frequency, lower frequency, higher frequency, Q value, and insertion loss are displayed.
Flatness	Displays gain, slope, and flatness between two markers on a trace.
RF filter	Displays insertion loss and peak-to-peak ripple of the passband, and the maximum signal magnitude in the stopband. The passband and stopband are defined by two pairs of markers.

Data analysis

Port impedance conversion	The function of conversion of the S-parameters measured at 50 Ω port into the values, which could be determined if measured at a test port with arbitrary impedance.
De-embedding	The function allows to mathematically exclude from the measurement result the effect of the fixture circuit connected between the calibration plane and the DUT. This circuit should be described by an S-parameter matrix in a Touchstone file.

Embedding	The function allows to mathematically simulate the DUT parameters after virtual integration of a fixture circuit between the calibration plane and the DUT. This circuit should be described by an S-parameter matrix in a Touchstone file.
S-parameter conversion	The function allows conversion of the measured S-parameters to the following parameters: reflection impedance and admittance, transmission impedance and admittance, and inverse S-parameters.
Time domain transformation	The function performs data transformation from frequency domain into response of the DUT to radiopulse in time domain. Time domain span is set by the user arbitrarily from zero to maximum, which is determined by the frequency step. Windows of various forms for better tradeoff between resolution and level of spurious sidelobes.
Time domain gating	The function mathematically removes unwanted responses in time domain what allows for obtaining frequency response without influence from the fixture elements. The function applies reverse transformation back to frequency domain to the user-defined span in time domain. Gating filter types: bandpass or notch. For better tradeoff between gate resolution and level of spurious sidelobes the following filter shapes are available: maximum, wide, normal and minimum.
Other features	
Reflectometer control	Using external personal computer via USB interface.
Familiar graphical user interface	Graphical user interface based on Windows operating system ensures fast and easy Reflectometer operation by the user. The software interface of PLANAR R54 is compatible with modern tablet PCs and laptops.
Saving trace data	Features saving the traces in graphical format and saving the data in Touchstone and *.csv (comma separated values) formats on the hard drive.
Remote control	
COM/DCOM	COM/DCOM automation is used for remote control and data exchange with the user software. The Reflectometer program runs as COM/DCOM server. The user program runs as COM/DCOM client. The COM client runs on Reflectometer PC. The DCOM client runs on a separate PC connected via LAN.

1.3 Ordering Information

1.3.1 Standard Accessories

The standard accessories supplied with PLANAR R54 Vector Reflectometer are as follows:

USB Cable	1 pc
USB flash drive with software and Operating Manual	1 pc

1.4 Principle of Operation

PLANAR R54 Vector Reflectometer consists of the Reflectometer Unit, some supplementary accessories, and personal computer (which is not supplied with the package). The Reflectometer Unit is powered and controlled by PC via USB-interface. The block diagram of the Reflectometer is represented in figure 1.1.

The Reflectometer Unit consists of a source oscillator, a local oscillator, a source power attenuator, a directional coupler and other components which ensure the Reflectometer operation. The test port is the source of the test signal. The incident and reflected signals from the directional coupler are supplied into the mixers, where they are converted into IF (180 kHz), and are transferred further to the 2-channel receiver. The 2-channel receiver, after filtration, digitally encodes the signals and supplies them for further processing (filtration, phase difference measurement, magnitude measurement) into the signal processor. The filters for the IF are digital and have passband from 100 Hz to 30 kHz. The combination of the assemblies of directional couplers, mixers, and 2-channel receiver forms two similar signal receivers.

An external PC controls the operation of the components of the PLANAR R54. To fulfill the S-parameter measurement, the Reflectometer supplies the source signal of the assigned frequency from test port to the DUT, then measures magnitude and phase of the signal reflected by the DUT, and after that compares these results to the magnitude and phase of the source signal.

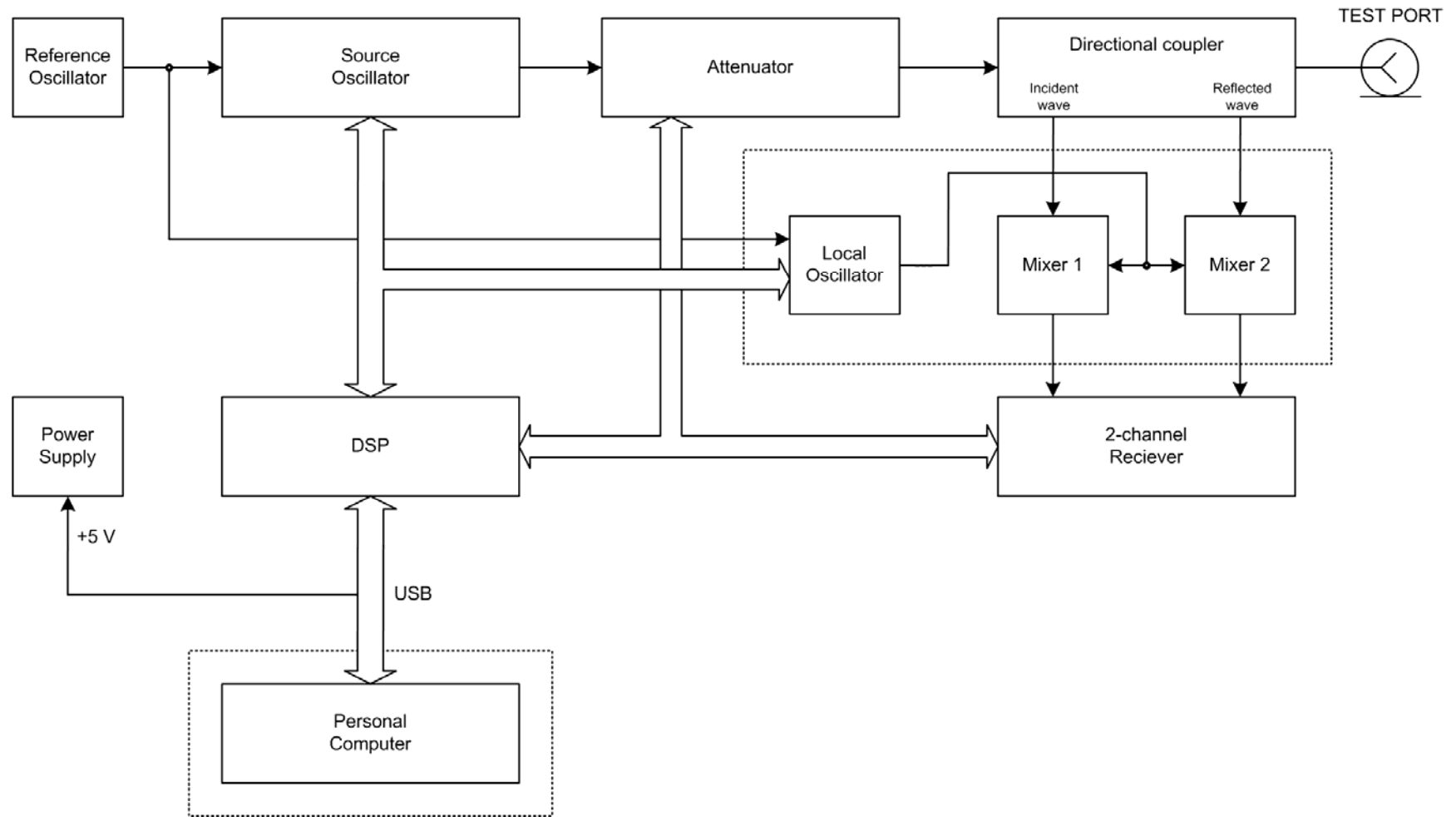

Figure 1.1 PLANAR R54 Vector Reflectometer block diagram

2 PREPARATION FOR USE

2.1 General Information

Unpack the Reflectometer and other accessories.

Connect PLANAR R54 Reflectometer to the PC using the USB Cable supplied in the package. Install the software (supplied on the flash drive) onto your PC. The software installation procedure is described below.

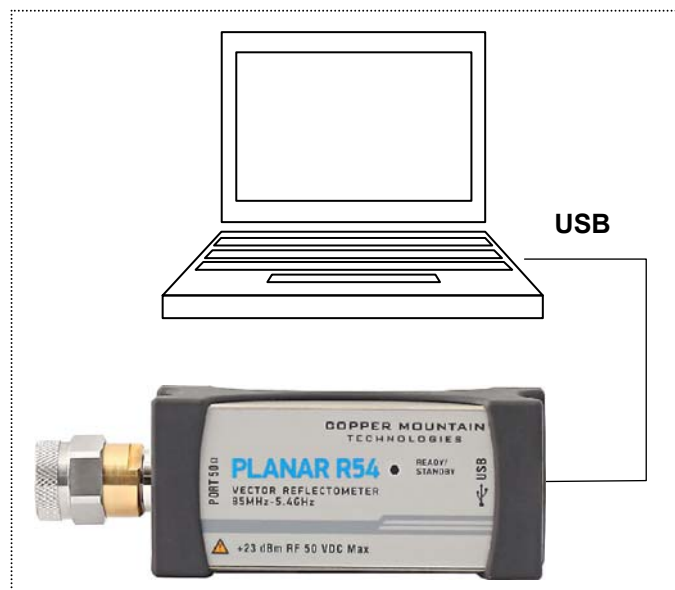

Warm-up the Reflectometer for 5 minutes after power-on.

Assemble the test setup using cables, connectors, fixtures, etc, which allow DUT connection to the Reflectometer.

Perform calibration of the Reflectometer. Calibration procedure is described in section 5.

2.2 Software Installation

The software is installed to the external PC running under Windows operating system. PLANAR R54 Reflectometer is connected to the external PC via USB interface.

Minimal system requirements for the PC	WINDOWS 2000/XP/VISTA/7
	1.5 GHz Processor
	1 GB RAM
	USB 2.0 High Speed

The supplied USB flash drive contains the following software.

Flash drive contents	<p>Setup_PlanarR54_vX.X.exe installer file</p> <p>(X.X – program version number)</p> <p>Setup_PlanarR54x2_vX.X.exe installer file to work with two devices</p> <p>Driver folder contains the driver</p> <p>Doc folder contains documentation</p>
----------------------	--

The procedure of the software installation is performed in two steps. The first one is the driver installation. The second step comprises installation of the program, documentation and other related files.

Driver installation	<p>Connect the Reflectometer to your PC via the supplied USB cable.</p> <p>When you connect the Reflectometer to the PC for the first time, Windows will automatically detect the new USB device and will open the USB driver installation dialog (Windows 2000/XP/VISTA/7).</p> <p>In the USB driver installation dialog, click on Browse and specify the path to the driver files, which are contained in the Driver folder on the USB flash drive.</p>
Program and related files installation	<p>Run the Setup_PlanarR54_vX.X.exe installer file from the supplied USB flash drive. Follow the instructions of the installation wizard.</p>
Additional program	<p>Run the Setup_PlanarR54x2_vX.X.exe installer file from the supplied USB flash drive. Follow the instructions of the installation wizard.</p>

2.3 Top Panel

The top panel view of PLANAR R54 is represented in figure 2.1. The top panel is equipped with the READY/STANDBY LED indicator running in the following modes:

- green blinking light – standby mode. In this mode the current consumption of the device from the USB port is minimum;
- green glowing light – normal device operation.



Figure 2.1 PLANAR R54 top panel

2.4 Test Port

The type-N male 50 Ω test port represented in figure 2.2 is intended for DUT connection. It is also used as a source of the stimulus signal and as a receiver of the response signal from the DUT.



Figure 2.2 Test port

2.5 Mini B USB Port

The mini B USB port view is represented in figure 2.3. It is intended for connection to USB port of the personal computer via the supplied USB cable.



Figure 2.3 Mini B USB port

3 GETTING STARTED

This section represents a sample session of the Reflectometer. It describes the main techniques of measurement of reflection coefficient parameters of the DUT. SWR and reflection coefficient phase of the DUT will be analyzed.

The instrument sends the stimulus to the input of the DUT and then receives the reflected wave. Generally in the process of this measurement the output of the DUT should be terminated with a LOAD standard. The results of these measurements can be represented in various formats. The given example represents the measurement of SWR and reflection coefficient phase.

Typical circuit of DUT reflection coefficient measurement is shown in figure 3.1.

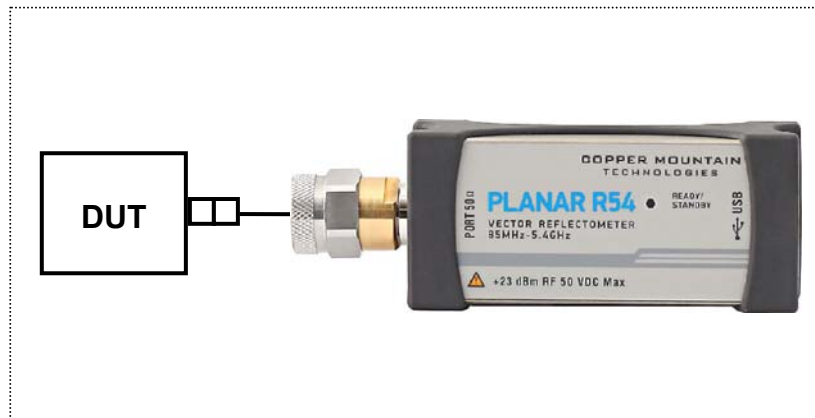

Figure 3.1.

To measure SWR and reflection coefficient phases of the DUT, in the given example you should go through the following steps:

- Prepare the Reflectometer for reflection measurement;
- Set stimulus parameters (frequency range, number of sweep points);
- Set IF bandwidth;
- Set the number of traces to 2, assign measured parameters and display format to the traces;
- Set the scale of the traces;
- Perform calibration of the Reflectometer for reflection coefficient measurement;
- Analyze SWR and reflection coefficient phase using markers.

3.1 Reflectometer Preparation for Reflection Measurement

Turn on the Reflectometer and warm it up for the period of time stated in the specifications.

Ready state features

The bottom line of the screen displays the instrument status bar. It should read Ready.

Connect the DUT to the test port of the Reflectometer. Use the appropriate adapters for connection of the DUT input to the Reflectometer test port. If the DUT input is type-N (female), you can connect the DUT directly to the port.

3.2 Reflectometer Presetting

Before you start the measurement session, it is recommended to reset the Reflectometer into the initial state. The initial condition setting is described in Appendix 1.

Note

You can operate PLANAR R54 either by the mouse or using a touch screen.

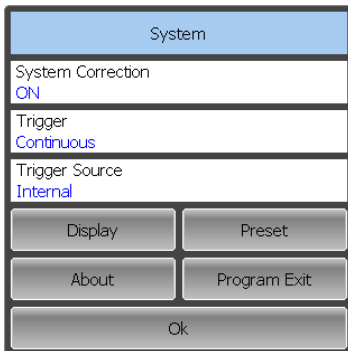

To restore the initial state of the Reflectometer, use the following softkeys in the left menu bar:

System > Preset

Close the dialog by

Ok

Right- and left-hand softkey menu bars can be collapse to the size of icons.

To expand the menu bar, click on it and drag the cursor to the right or to the left accordingly.

To collapse the menu bar, click on it and drag the cursor to the right or to the left accordingly.

3.3 Stimulus Setting

After you have restored the preset state of the Reflectometer, the stimulus parameters will be as follows: frequency range from 85 MHz to 5.4 GHz, sweep type is linear, number of sweep points is 201, power level is high, and IF is 10 kHz.

For the current example, set the frequency range to from 100 MHz to 1 GHz.



Stimulus	
Start Frequency	85 MHz
Stop Frequency	5.4 GHz
Max Distance	1.498962 m
Points	201
Power	High
Sweep Type	Lin
<input type="button" value="segment Table"/> <input type="button" value="Ok"/>	

100				MHz
1	2	3	←	GHz
4	5	6		MHz
7	8	9	±	kHz
0	.	←	→	Hz
Cancel		Ok		

To set the start frequency of the frequency range to 100 MHz, use the following softkey in the right menu bar:

Stimulus

Then select the **Start Frequency** field and enter 100 using the on-screen keypad. Complete the setting by

Ok

To set the stop frequency of the frequency range to 1 GHz, select the **Stop Frequency** field and enter 1000 using the on-screen keypad. Complete the setting

Ok

Close the **Stimulus** dialog by

Ok

3.4 IF Bandwidth Setting

For the current example, set the IF bandwidth to 3 kHz.



To set the IF bandwidth to 3 kHz, use the following softkey in the left menu bar:

Average

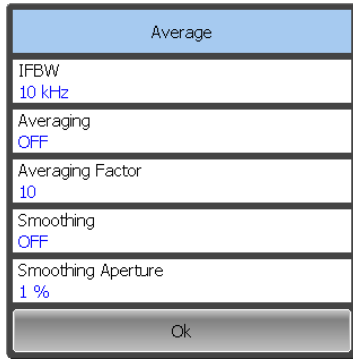

Then select the **IFBW** field in the **Average** dialog.

To set the IF bandwidth in the **IFBW** dialog, use the following softkeys:

3 kHz > Ok

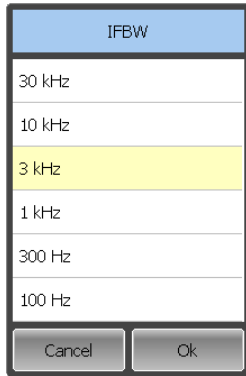

Note

You can also select the IF bandwidth by double clicking on the required value in the IFBW. The dialog will close automatically.

3.5 Number of Traces, Measured Parameter and Display Format Setting

In the current example, two traces are used for simultaneous display of the two parameters (SWR and reflection coefficient phase).



To add the second trace, use the following softkeys in the right menu bar:

Trace > Add trace

The added trace automatically becomes active. The active trace is highlighted in the list and on the graph.

To select the second trace display format, double click on its name, and **Measurement** dialog will appear.

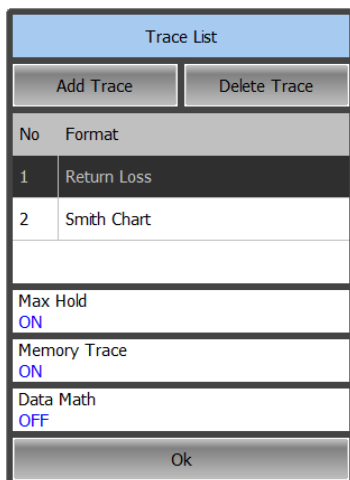

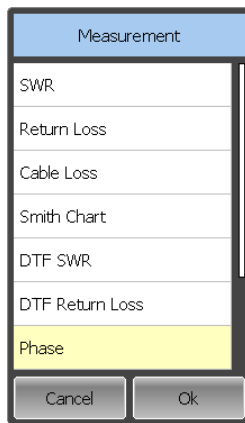

Set the Phase format by

Phase > Ok

To scroll up and down the formats list click on the list field and drag the mouse up or down accordingly.

To select the first trace display format, double click on its name, and in the Measurement dialog use the following softkeys:

SWR > Ok

Close the Trace List dialog by

Ok

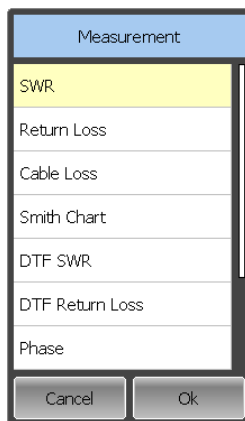

3.6 Trace Scale Setting

For a convenience in operation, change the trace scale using automatic scaling function.



To set the scale of the active trace by the autoscaling function, use the following softkeys in the right menu bar:

Scale > Auto Scale > Ok

The program will automatically set the scale to the best display of the active trace.

Note

To activate a trace, use the following softkey:

Trace

Then select the required trace in the list that will appear.

3.7 Reflectometer Calibration for Reflection Coefficient Measurement

Calibration of the whole measurement setup, which includes the Reflectometer and other devices, supporting connection to the DUT, allows to considerably enhance the accuracy of the measurement.

To perform full 1-port calibration, you need to prepare the kit of calibration standards: OPEN, SHORT and LOAD. Such a kit has its description and specifications of the standards.

To perform proper calibration, you need to select in the program the correct kit type. In the process of full 1-port calibration, connect calibration standards to the test port one after another, as shown in figure 3.2.

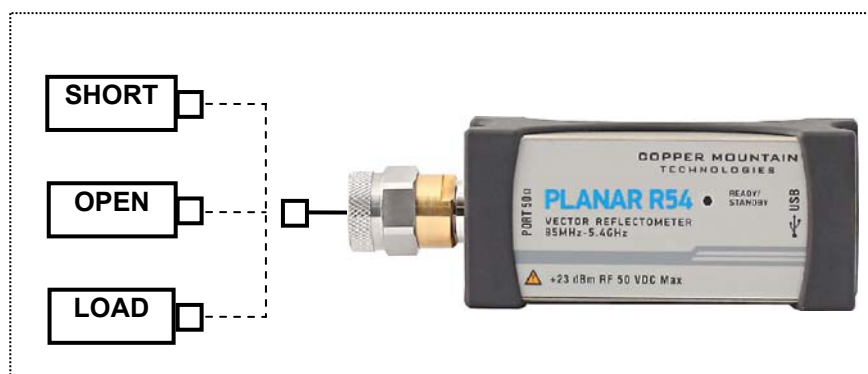
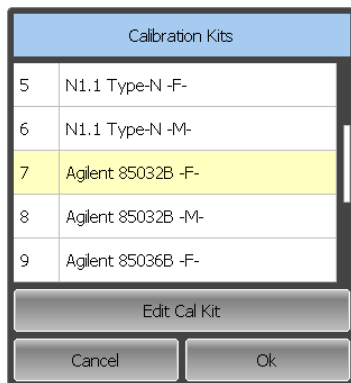

Figure 3.1. Full 1-port calibration circuit

In the current example Agilent 85032B/E calibration kit is used.



To select the calibration kit, use the following softkeys in the left menu bar:

Calibration > Calibration Kit

Then select the required kit from the Calibration Kits list and complete the setting by

Ok

To perform full 1-port calibration, execute measurements of the three standards. After that the table of calibration coefficients will be calculated and saved into the memory of the Reflectometer. Before you start calibration, disconnect the DUT from the Reflectometer.



To perform full 1-port calibration, use the following softkey in the left menu bar:

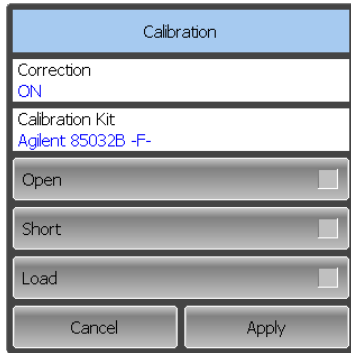

Calibration

Connect an OPEN standard and click

Open

Connect a SHORT standard and click

Short

Connect a LOAD standard and click

Load

After clicking any of the **Open**, **Short**, or **Load** softkeys, wait until the calibration procedure is completed.

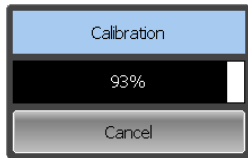

To complete the calibration and calculate the table of calibration coefficients, click

Apply

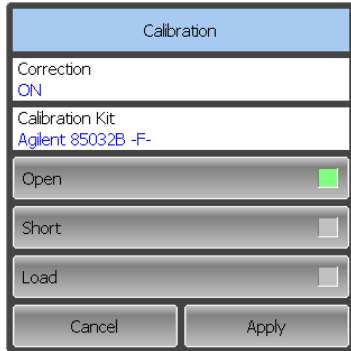

Then re-connect the DUT to the Reflectometer test port.

3.8 SWR and Reflection Coefficient Phase Analysis Using Markers

This section describes how to determine the measurement values at three frequency points using markers. The Reflectometer screen view is shown in figure 3.1. In the current example, a reflection standard of SWR = 1.2 is used as a DUT.

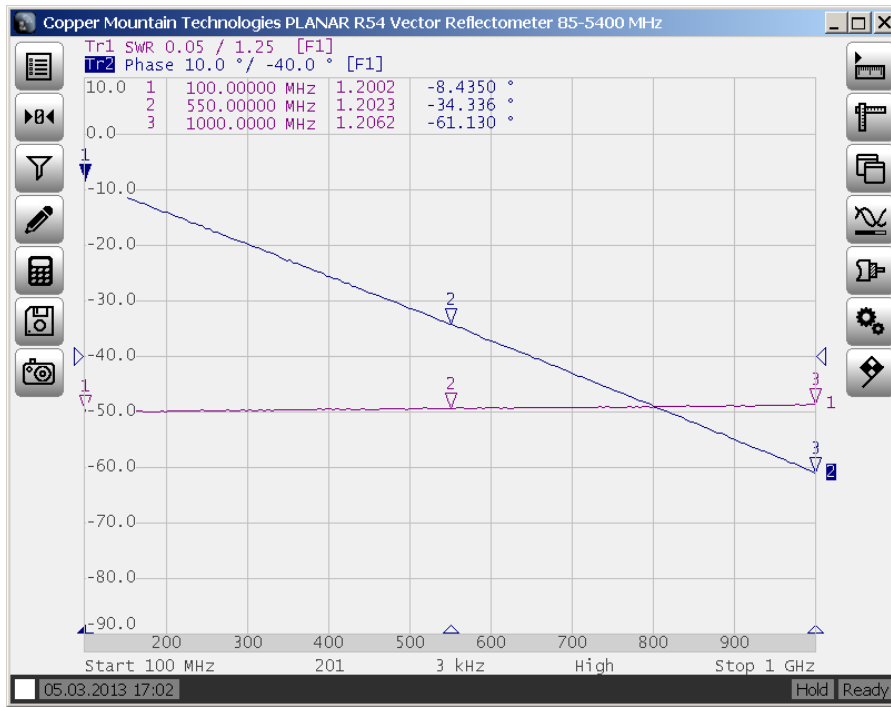

Figure 3.1 SWR and reflection coefficient phase measurement example



Marker List	
Add Marker	Delete Marker
1	100.00000 MHz
2	550.00000 MHz
3	1000.00000 MHz
Reference Marker OFF	
Search	Properties
Math	Ok

To enable a new marker, use the following softkeys in the left menu bar:

Marker > Add Marker

Double click on the marker in the Marker List to activate the on-screen keypad and enter the marker frequency value.

Complete the setting by

Ok

On-screen alphanumeric keypads also support data entering from external PC keyboard. Besides, you can navigate the menu by «↑», «↓», «←», «→», «Enter», «Esc» keys on the external keyboard.

To expand the left-hand softkey menu bar, click on it and drag the cursor to the right. To expand the right-hand menu bar, drag the cursor to the left accordingly. To collapse the left-hand softkey menu bar, click on it and drag the cursor to the left, and to collapse the right-hand menu bar, drag the cursor to the right accordingly.

4.1.2 Instrument Status Bar



Figure 4.2 Instrument status bar

The instrument status bar is located at the bottom of the screen. It can contain the following messages (see table 4.1).

Table 4.1 Messages in the instrument status bar

Field Description	Message	Instrument Status
DSP status	Not Ready	No communication between DSP and computer.
	Loading	DSP program is loading.
	Ready	DSP is running normally.
	Standby	DSP is in energy saving standby mode.
Sweep status	Measure	Continuous sweep.
	Hold	A sweep is on hold.
Factory calibration error	System Cal Failure	ROM error of system calibration.
Error correction status	Correction Off	Error correction disabled by the user ⁴ .
System correction status	System Correction Off	System correction disabled by the user.

⁴ Disabling of error correction does not affect factory calibration.

4.2.1 Channel Title Bar

The channel title feature allows you to enter your comment for each channel window.



To show/hide the channel title bar, use the following softkeys:

System > Display

Click on **Caption** field in the opened dialog.

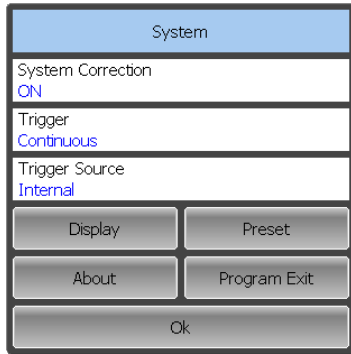

Note

To edit the channel title, click on the title to recall the on-screen keypad.

4.2.2 Trace Status Field

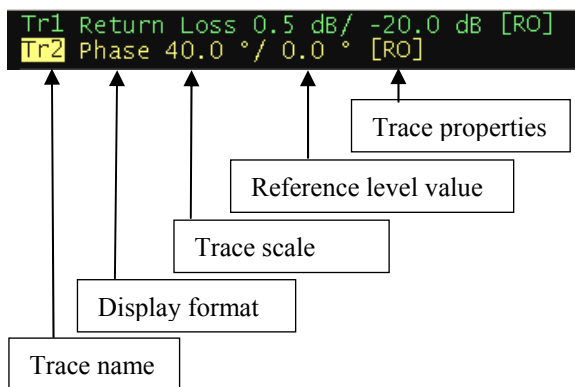

Figure 4.4 Trace status field

The trace status field displays the name and parameters of a trace. The number of lines in the field depends on the number of traces in the channel.

Note	Using the trace status, field you can easily modify the trace parameters by the mouse.
------	--

Each line contains the data on one trace of the channel:

- Trace name from Tr1 to Tr4. The active trace name is highlighted in inverted color;
- Display format, e.g. Return Loss;
- Trace scale in measurement units per division, e.g. 0.5 dB/;
- Reference level value, e.g. -20.0 dB;

Trace status is indicated as symbols in square brackets (See table 4.2).

Table 4.2 Trace status symbols definition

Status	Symbols	Definition
Error Correction	RO	OPEN response calibration
	RS	SHORT response calibration
	F1	Full 1-port calibration
Data Analysis	Z0	Port impedance conversion
	Dmb	De-embedding
	Emb	Embedding
	Pxt	Port extension
Math Operations	D+M	Data + Memory
	D-M	Data - Memory
	D*M	Data * Memory
	D/M	Data / Memory
Maximum Hold	Max	Hold of the trace maximum between repeated measurements
Electrical Delay	Del	Electrical delay other than zero
Phase Offset	PhO	Phase offset value other then zero
Smoothing	Smo	Trace smoothing
Gating	Gat	Time domain gating
Conversion	Zr	Reflection impedance
	Yr	Reflection admittance
	1/S	S-parameter inversion
	Conj	Conjugation

4.2.3 Graph Area

The graph area displays the traces and numeric data (see figure 4.5).

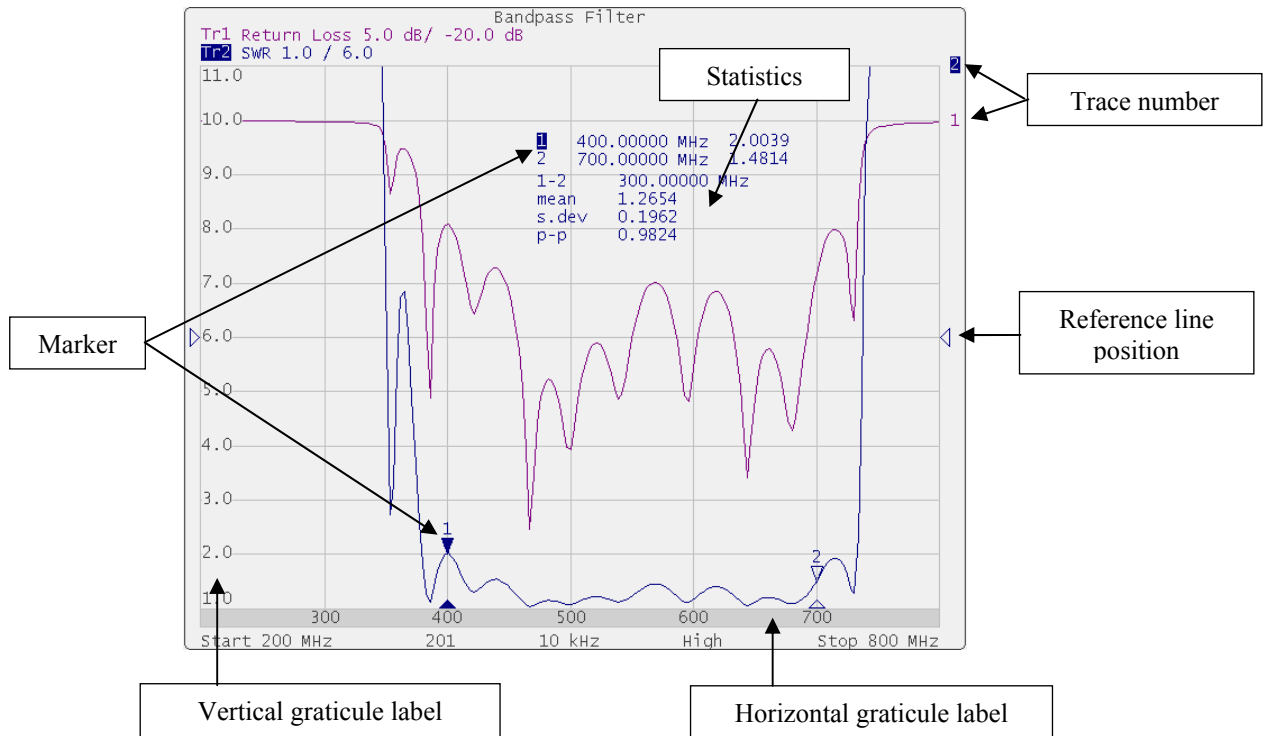

Figure 4.5 Graph area

The graph area contains the following elements:

Vertical graticule label displays the vertical axis numeric data for the active trace.

Horizontal graticule label displays stimulus axis numeric data (frequency, time, or distance).

Reference level position indicates the reference level position of the trace.

Markers indicate the measured values in different points on the active trace. You can enable display of the markers for all the traces simultaneously.

Marker functions: statistics, bandwidth, flatness, RF filter.

Trace number allows trace identification in the channel window.

Current stimulus position indication appears when sweep duration exceeds 1 sec.

Note

Using the graticule labels, you can easily control all the trace parameters by the mouse.

4.2.4 Markers

The markers indicate the stimulus values and the measured values in selected points of the trace (See figure 4.6).

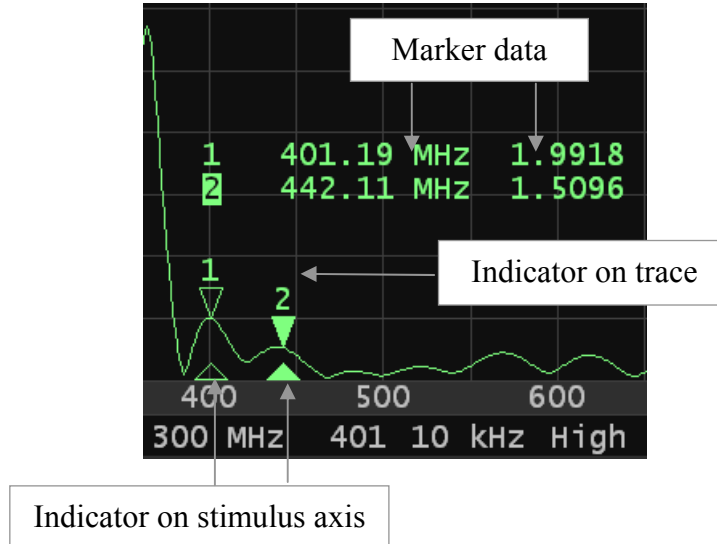

Figure 4.6 Markers

The markers are numbered from 1 to 16. The reference marker is indicated with R symbol. The active marker is indicated in the following manner: its number is highlighted in inverse color, the stimulus indicator is fully colored.

4.2.5 Channel Status Bar

The channel status bar is located in the bottom part of the channel window. It contains the following elements (see figure 4.7):

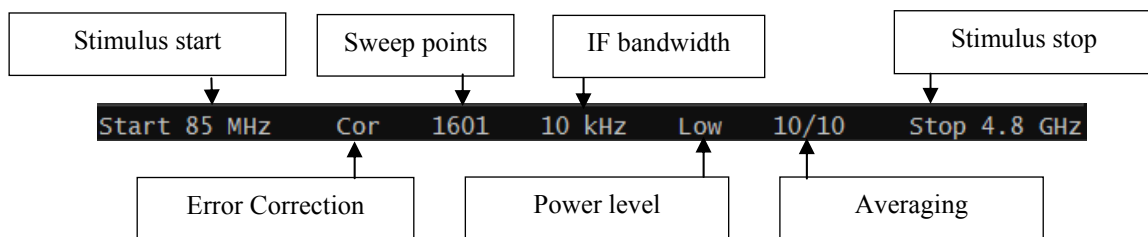

Figure 4.7 Channel status bar

- *Stimulus start* field allows for display and entry of the start frequency. This field can be switched to indication of stimulus center frequency, in this case the word Start will change to Center.

- *Sweep points* field allows for display and entry of the number of sweep points. The number of sweep points can have the following values: 2 - 16001.
- *IF bandwidth* field allows for display and setting of the IF bandwidth. The values can be set from 100 Hz to 30 kHz.
- *Power level* field allows for display and entry of the port output power.
- *Stimulus stop* field allows for display and entry of the stop frequency . This field can be switched to indication of stimulus span, in this case the word Stop will change to Span.
- *Error correction* field displays the integrated status of error correction for S-parameter traces. The values of this field are represented in table 4.3

Table 4.3 Error correction field

Symbol	Definition
--	No calibration data. No calibration was performed.
Cor	Error correction is enabled. The stimulus settings are the same for the measurement and the calibration.
C?	Error correction is enabled. The stimulus settings are not the same for the measurement and the calibration. Interpolation is applied.
C!	Error correction is enabled. The stimulus settings are not the same for the measurement and the calibration. Extrapolation is applied.
Off	Error correction is turned off.

4.3.3 Display Format Setting

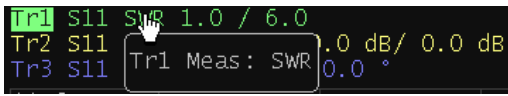

To select the trace display format, click on the format name in the trace status line.

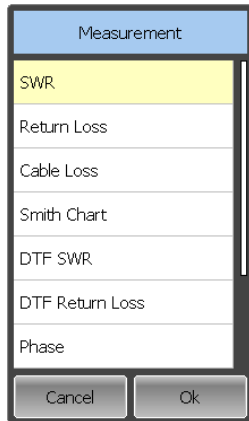

Select the required format in the **Measurement** dialog and complete the setting by

Ok

4.3.4 Trace Scale Setting



To select the trace scale, click in the trace scale field of the trace status line.

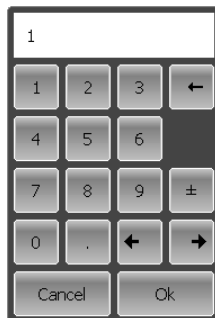

Enter the required numerical value using the on-screen keypad and complete the setting by

Ok

4.3.5 Reference Level Setting



To set the value of the reference level, click on the reference level field in the trace status line.

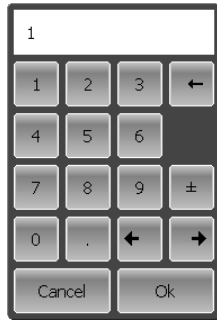

Enter the required numerical value using the on-screen keypad and complete the setting by

Ok

4.3.6 Marker Stimulus Value Setting

The marker stimulus value can be set by dragging the marker or by entering the value from the on-screen keypad.

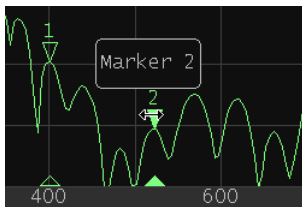

To drag the marker, move the mouse pointer to one of the marker indicators. The marker will become active, and a pop-up hint with its name will appear near the marker. The marker can be moved either by dragging its indicator or its hint area.

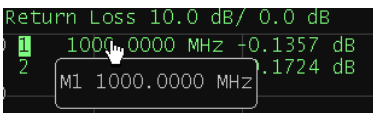

To enter the numerical value of the stimulus in the marker data, click on the stimulus value. Then enter the required value using the on-screen keypad.

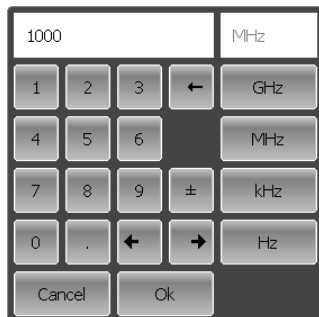

4.3.7 Switching between Start/Center and Stop/Span Modes

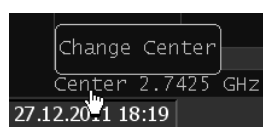
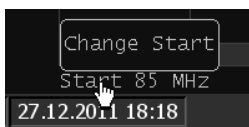

replaced by **Span**.

To switch between the modes Start/Center and Stop/Span, click in the respective field of the channel status bar. Label **Start** will be replaced by **Center**, and label **Stop** will be

4.3.8 Start/Center Value Setting



To enter the **Start/Center** numerical values, click on the respective field in the channel status bar.

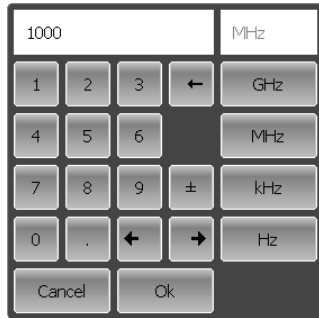

Then enter the required value using the on-screen keypad.

4.3.9 Stop/Span Value Setting



To enter the **Stop/Span** numerical values, click on the respective field in the channel status bar.

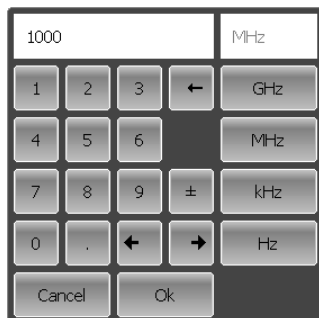

Then enter the required value using the on-screen keypad.

4.3.10 Sweep Points Number Setting



To enter the number of sweep points, click in the respective field of the channel status bar.

Points
10001
1601
801
401
201
101
More...
Cancel
Ok

Select the required value in the **Points** dialog and complete the setting by

Ok

4.3.11 IF Bandwidth Setting

To set the IF bandwidth, click in the respective field of the channel status bar.

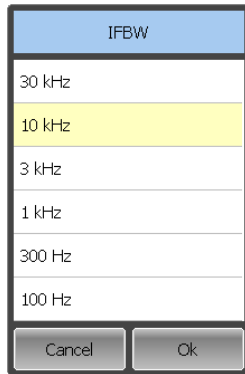

Select the required value in the **IFBW** dialog and complete the setting by

Ok

4.3.12 Power Level Setting



To set the output power level, click in the respective field of the channel status bar. This way you can switch between high and low power settings.

4.4 Channel and Trace Display Setting

The Reflectometer supports 4 channels, which allow measurements with different stimulus parameter settings. The parameters related to a logical channel are listed in table 4.4.

4.4.1 Setting the Number of Channel Windows

A channel is represented on the screen as an individual channel window. The screen can display from 1 to 4 channel windows simultaneously. By default one channel window opens.

The program supports three options of channel window layout: one channel, two channels, and four channels. The channels are allocated on the screen according to their numbers from left to right and from top to bottom. If there are more than one channel window on the screen, one of them is selected as active. The border line of the active window will be highlighted in light color.



To set the number of channel windows displayed on the screen, use the following softkey in the right menu bar:

Channels

Then select the softkey with the required number and layout of the channel windows.

In the **Active Channel** field, you can select the active channel. The repeated clicking will switch the numbers of all channels.

Note

For each open channel window, you should set the stimulus parameters and make other settings.

Before you start a channel parameter setting or calibration, you need to select this channel as active.

The measurements are executed for open channel windows in succession.

4.4.2 Channel Activating

Before you set channel parameters, first you need to activate the channel.

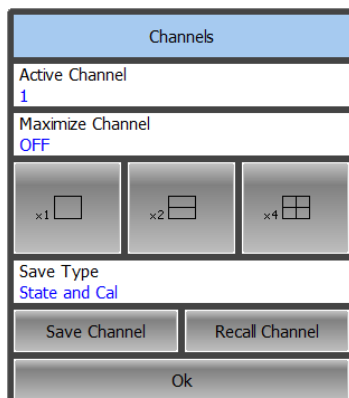

To activate a channel, use the following softkeys in the right menu bar:

Channels > Active Channel

Active Channel field allows viewing the numbers of all channels from 1 to 4. Select the required number of the active channel.

To activate a channel, you can also click on its channel window.

4.4.3 Active Channel Window Maximizing

When there are several channel windows displayed, you can temporarily maximize the active channel window to full screen size.

The other channel windows will be hidden, and this will interrupt the measurements in those channels.



To enable/disable active channel maximizing function, use the following softkeys:

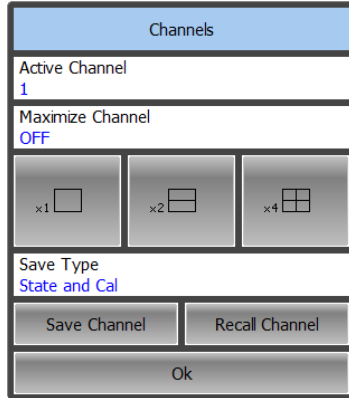

Channel > Maximize Channel

Note

Channel maximizing function can be controlled by a double mouse click on the channel.

4.4.4 Number of Traces Setting

Each channel window can contain up to 4 different traces. Each trace is assigned the display format, scale and other parameters. The parameters related to a trace are listed in table 4.5.

The traces can be displayed in one graph, overlapping each other, or in separate graphs of a channel window. The trace settings are made in two steps: trace number setting and trace layout setting in the channel window. By default a channel window contains one trace. If you need to enable two or more traces, set the number of traces as described below.



To add a trace, use the following softkeys in the right menu bar:

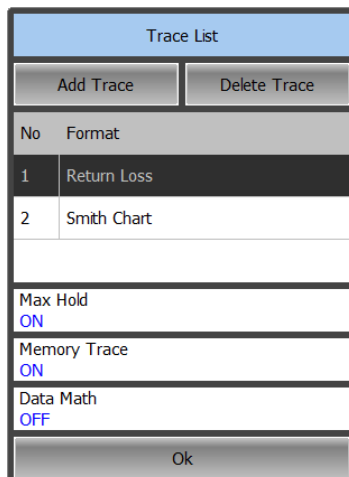

Trace > Add Trace

Active trace is highlighted.



To delete a trace, use the following softkeys in the right menu bar:

Trace > Delete Trace

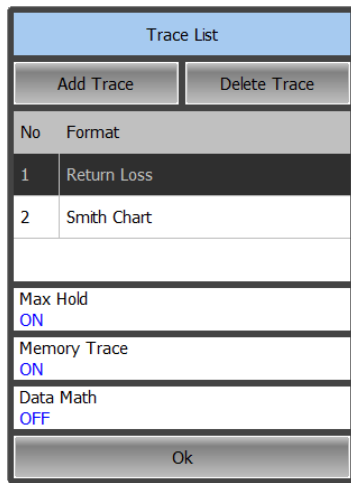

All the traces are assigned their individual names, which cannot be changed. The trace name contains its number. The trace names are as follows: Tr1, Tr2 ... Tr4.

Each trace is assigned some initial settings: measured parameter, format, scale, and color, which can be modified by the user.

By default the display format for all the traces is set to Return loss (dB).

By default the scale is set to 10 dB на деление, reference level value is set to 0 dB, reference level position is in the middle of the graph.

The trace color is determined by its number.

4.4.5 Active Trace Selection

Trace parameters can be entered for the active trace. Active trace belongs to the active channel, and its name is highlighted in inverted color. You have to select the active trace before setting the trace parameters.

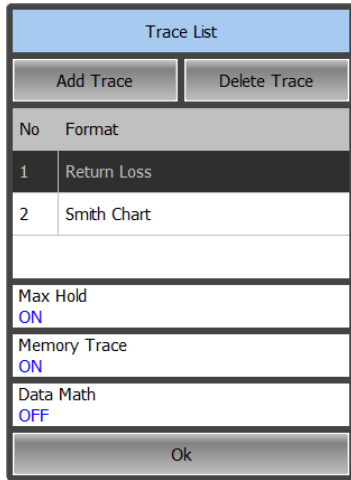

To select the active trace, use the following softkeys in the right menu bar

Trace

From the **Trace List**, select the trace you want to assign the active.

Note

A trace can be activated by clicking on the trace status bar in the graphical area of the program

Table 4.4 Channel parameters

N	Parameter Description
1	Sweep Range
2	Number of Sweep Points
3	IF Bandwidth

Table 4.5 Trace parameters

N	Parameter Description
1	Display Format
2	Reference Level Scale, Value and Position
3	Electrical Delay, Phase Offset
4	Memory Trace
5	Markers
6	Parameter Transformation

4.5 Measurement Parameters Setting

4.5.1 S-Parameters

For high-frequency network analysis the following terms are applied: incident, reflected and transmitted waves, transferred in the circuits of the setup (See figure 4.9).

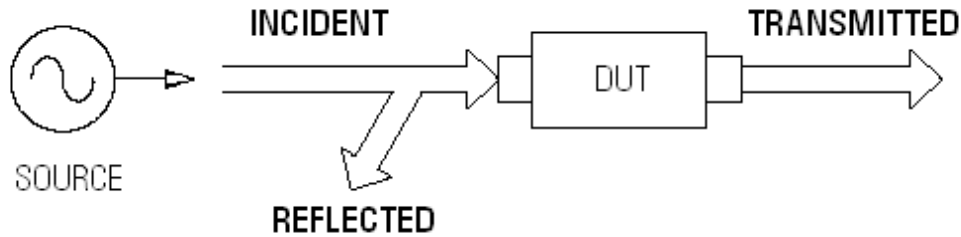

Figure 4.9

Measurement of magnitude and phase of incident, reflected and transmitted signals allow to determining the S-parameters (scattered parameters) of the DUT. An S-parameter is a relation between the complex magnitudes of the two waves:

$$S_{mn} = \frac{\text{transmitted wave at Port } m}{\text{incident wave at Port } n}$$

PLANAR R54 Reflectometer has one measurement port which operates as a signal source and as a reflected signal receiver. That is why the Reflectometer allows measuring only S11 parameter.

4.5.2 Trace Format

The Reflectometer offers the display of the measured S-parameters on the screen in two formats:

- rectangular format;
- Smith chart format.

4.5.3 Rectangular Format

In this format, stimulus values are plotted along X-axis and the measured data are plotted along Y-axis (See figure 4.9).

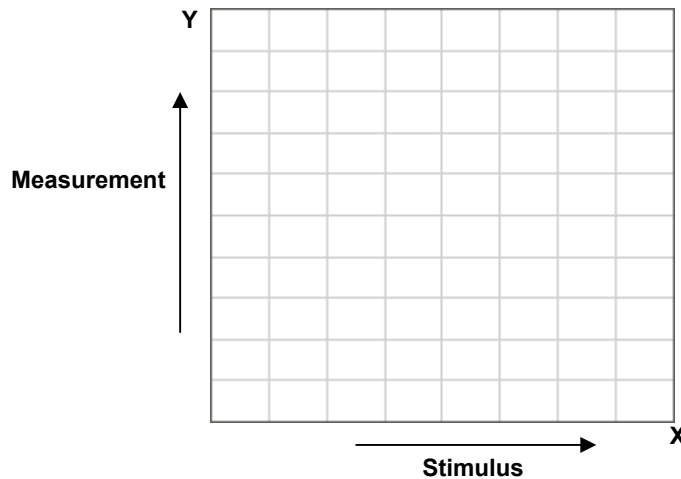

Figure 4.9 Rectangular format

To display S-parameter complex value along Y-axis, it should be transformed into a real number. Rectangular formats involve various types of transformation of an S-parameter

$$S = a + j \cdot b, \text{ where:}$$

a – real part of S-parameter complex value;

b – imaginary part of S-parameter complex value.

There are seven types of rectangular formats depending on the measured value plotted along Y-axis (See table 4.6).

Rectangular format also refers to the measured data after their conversion from frequency domain to time domain (DTF). Such conversion is performed with by the Fourier inverse transform operation.

Table 4.6 Rectangular formats

Format Type Description	Label	Data Type (Y-axis)	Measurement Unit (Y-axis)
Logarithmic Magnitude	Return Loss	S-parameter logarithmic magnitude: $A = 20 \cdot \log S $, $ S = \sqrt{a^2 + b^2}$	Decibel (dB)
Cable Loss	Cable Loss	$A = \frac{1}{2} \cdot (\text{ReturnLoss})$ $A = 10 \cdot \log S $	Decibel (dB)
Voltage Standing Wave Ratio	SWR	$SWR = \frac{1 + S }{1 - S }$	Abstract number
Phase	Phase	S-parameter phase from -180° to $+180^\circ$: $\Phi = \frac{180}{\pi} \cdot \text{arctg} \frac{a}{b}$	Degree ($^\circ$)
Expanded Phase	Expand. Phase	S-parameter phase, measurement range expanded to from below -180° to over $+180^\circ$	Degree ($^\circ$)
Group Delay	Group Delay	Signal propagation delay within the DUT: $t = - \frac{d\varphi}{d\omega}$, $\varphi = \text{arctg} \frac{a}{b}$, $\omega = 2 \pi f$	Second (sec.)
Linear Magnitude	Lin Mag	S-parameter linear magnitude: $ S = \sqrt{a^2 + b^2}$	Abstract number

4.5.4 Smith Chart Format

Smith chart format is used for representation of impedance values for DUT reflection measurements.

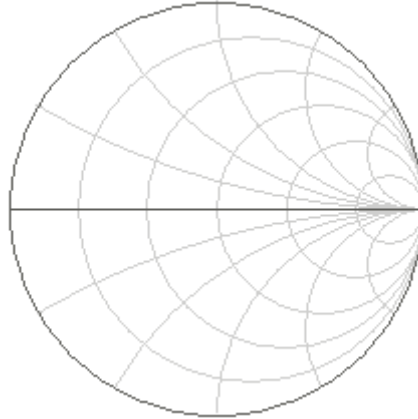

Figure 4.10 Smith chart format

Smith chart format does not have a frequency axis, so frequency will be indicated by the markers.

Table 4.7 Smith chart format

Format Type Description	Label	Data Displayed by Marker	Measurement Unit (Y-axis)
Complex Impedance (at Input)	Smith Chart	Resistance at input: $R = re(Z_{inp})$, $Z_{inp} = Z_0 \frac{1+S}{1-S}$	Ohm (Ω)
		Reactance at input: $X = im(Z_{inp})$	Ohm (Ω)
		Equivalent capacitance or inductance: $C = -\frac{1}{\omega X}, X < 0$ $L = \frac{X}{\omega}, X > 0$	Farad (F) Henry (H)

4.5.5 Trace Format Setting

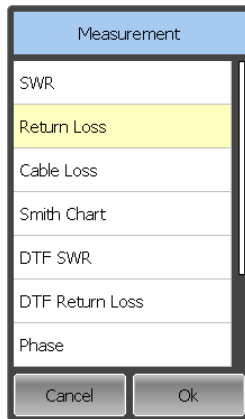
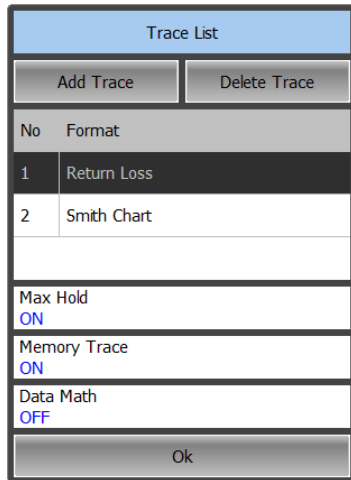

To set the trace display format, use the following softkey in the right menu bar:

Trace

In the Trace List dialog select the required trace and double-click on it.

Then select the required format in the Measurements dialog. Complete the setting by

Ok

Note

DTF SWR and DTF Return Loss formats can be selected only for linear frequency scanning mode.

If the frequency scanning mode is other than linear, then it will be automatically switched to linear after selecting these formats of the graph.

If you select DTF SWR or DTF Return Loss formats of the graph, but the frequency scanning mode selected is other than linear, the graph format will be automatically switched to default value of Return Loss.

4.6 Scale Setting

4.6.1 Rectangular Scale

For rectangular format you can set the following parameters (See figure 4.11):

- Trace scale;
- Reference level value;
- Reference level position;
- Number of scale divisions.

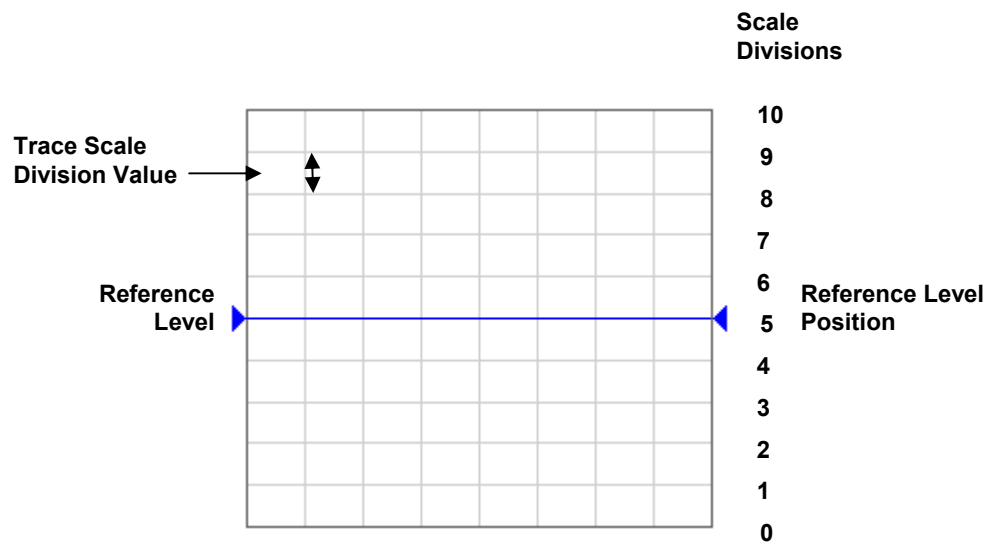

Figure 4.11 Rectangular scale

4.6.2 Rectangular Scale Setting

You can set the scale for each trace of a channel. Before you set the scale, first activate the trace.



To set the scale of a trace, use the following softkey in the right menu bar:

Scale

Then select the **Scale** field and enter the required value using the on-screen keypad.

To set the reference level, select the **Ref. Value** field and enter the required value using the on-screen keypad.

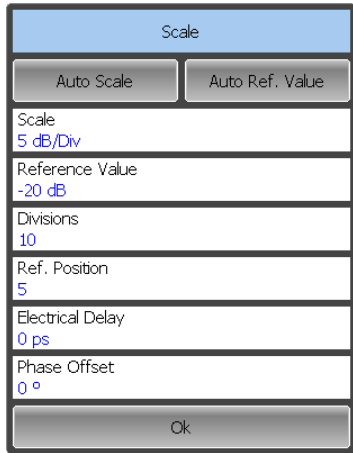

To set the position of the reference level, select the **Ref. Position** field and enter the required value using the on-screen keypad.

To set the number of trace scale divisions⁵, select the **Divisions** field and enter the required value using the on-screen keypad.

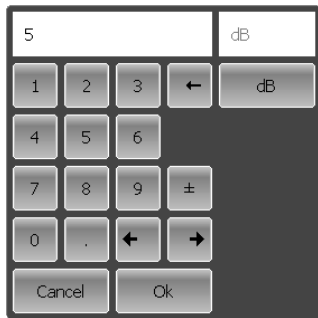

4.6.3 Circular Scale

For polar and Smith chart format, you can set the outer circle value (See figure 4.12).

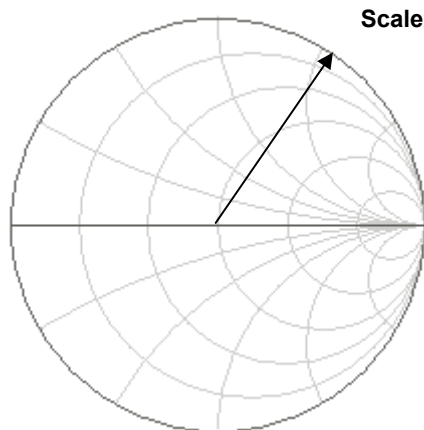

Figure 4.12 Circular scale

⁵ The number of scale divisions affects all channel traces.

4.6.4 Circular Scale Setting



Scale	
Auto Scale	Auto Ref. Value
Scale	0,1
Reference Value	0,5
Divisions	10
Ref. Position	5
Electrical Delay	0 ps
Phase Offset	0 °
Ok	

To set the scale of the circular graph, use the following softkey in the right menu bar:

Scale

Then select the **Scale** field and enter the required value using the on-screen keypad.

4.6.5 Automatic Scaling

The automatic scaling function allows the user to automatically define the trace scale so that the trace of the measured value could fit into the graph entirely.

In rectangular format, two parameters are adjustable: scale and reference level position. In circular format, the outer circle value will be adjusted.



Scale	
Auto Scale	Auto Ref. Value
Scale	0,1
Reference Value	0,5
Divisions	10
Ref. Position	5
Electrical Delay	0 ps
Phase Offset	0 °
Ok	

To execute the automatic scaling, use the following softkeys in the right menu bar:

Scale > Auto Scale

4.6.6 Reference Level Automatic Selection

This function executes automatic selection of the reference level in rectangular coordinates.

After the function has been executed, the trace of the measured value makes the vertical shift so that the reference level crosses the graph in the middle. The scale will remain the same.



Scale	
Auto Scale	Auto Ref. Value
Scale	0,1
Reference Value	0,5
Divisions	10
Ref. Position	5
Electrical Delay	0 ps
Phase Offset	0 °
Ok	

To execute the automatic selection of the reference level, use the following softkeys in the right menu bar:

Scale > Auto Ref. Value

4.6.7 Electrical Delay Setting

The electrical delay function allows the user to define the compensation value for the electrical delay of a device. This value is used as compensation for the electrical delay during non-linear phase measurements. The electrical delay is set in seconds.

If the electrical delay setting is other than zero, S-parameter value will vary in accordance with the following formula:

$$S = S \cdot e^{j \cdot 2 \pi f \cdot t}, \text{ where}$$

f – frequency, Hz,
 t – electrical delay, sec.

The electrical delay is set for each trace individually. Before you set the electrical delay, first activate the trace.



Scale	
Auto Scale	Auto Ref. Value
Scale	0,1
Reference Value	0,5
Divisions	10
Ref. Position	5
Electrical Delay	0 ps
Phase Offset	0 °
Ok	

To set the electrical delay, use the following softkey in the right menu bar:

Scale

Then select the **Electr. Delay** field and enter the required value using the on-screen keypad.

4.6.8 Phase Offset Setting

The phase offset function allows the user to define the constant phase offset of a trace. The value of the phase offset is set in degrees for each trace individually. Before you set the phase offset, first activate the trace.



Scale	
Auto Scale	Auto Ref. Value
Scale	0,1
Reference Value	0,5
Divisions	10
Ref. Position	5
Electrical Delay	0 ps
Phase Offset	0 °
Ok	

To set the phase offset, use the following softkey in the right menu bar:

Scale

Then select the **Phase Offset** field and enter the required value using the on-screen keypad.

4.7 Stimulus Setting

The stimulus parameters are set for each channel. Before you set the stimulus parameters of a channel, make this channel active.

4.7.1 Sweep Type Setting



Stimulus	
Start Frequency	200 MHz
Stop Frequency	800 MHz
Max Distance	1.498962 m
Points	201
Power	High
Sweep Type	Lin
segment Table	Ok

Sweep Type	
Lin	
Log	
Segment	
Cancel	Ok

To set the sweep type, use the following softkey in the right menu bar:

Stimulus

Then click on **Sweep Type** field, select the required type from the list and complete the setting by

Ok

Note

If you select segment frequency sweep, the Segment Table softkey will be become available in Stimulus dialog. For segment tables details see section 4.7.6.

4.7.2 Sweep Span Setting



Stimulus	
Start Frequency	200 MHz
Stop Frequency	800 MHz
Max Distance	1.498962 m
Points	201
Power	High
Sweep Type	Lin
segment Table	Ok

200				MHz
1	2	3	←	GHz
4	5	6		MHz
7	8	9	±	kHz
0	.	←	→	Hz
Cancel		Ok		

To enter the start and stop values of the sweep range, use the following softkey in the right menu bar:

Stimulus

Then select the **Start Frequency.** or **Stop Frequency.** field and enter the required values using the on-screen keypad.

If necessary, you can select the measurement units. The current measurement units are shown to the right from the value entry field.

4.7.3 Sweep Points Setting



Stimulus	
Start Frequency	200 MHz
Stop Frequency	800 MHz
Max Distance	1.498962 m
Points	201
Power	High
Sweep Type	Lin
<input type="button" value="Segment Table"/> <input type="button" value="Ok"/>	

Points	
10001	
1601	
801	
401	
201	
101	
51	
<input type="button" value="Cancel"/> <input type="button" value="Ok"/>	

To enter the number of sweep points, use the following softkey in the right menu bar:

Stimulus

Then click on **Points** field, select the required value from the list and complete the setting by

Ok

4.7.4 Distance to Fault Maximum Value Setting

In DTF mode the Reflectometer transforms the measured data in frequency domain to data in time domain by applying the Fourier inverse transform operation. If velocity factor of the measured trace is known, for example in coaxial cable, the time intervals are recalculated into distances.

To turn the DTF mode on, select DTF SWR or DTF Return Loss trace formats. The trace format selection is described in section 4.4.4.

The transformation function allows for setting of the measurement range in time domain within the limits of ambiguity range. The ambiguity range is determined by the measurement step in the frequency domain:

$$\Delta T = \frac{1}{\Delta F} = \frac{N-1}{F_{\max} - F_{\min}}, \text{ where:}$$

N – number of measurement points,

F_{min} – stimulus start frequency,

F_{max} – stimulus stop frequency.

The ambiguity range is recalculated into the maximum operating DTF value:

$$DTF_{\max} = \frac{C \cdot V_p \cdot \Delta T}{2} = \frac{C \cdot V_p \cdot (N-1)}{2 \cdot (F_{\max} - F_{\min})}, \text{ where:}$$

C – velocity of light in vacuum;

V_p – cable velocity factor.

The **Max. distance** value set by the user should be lower than DTF_{max} value.

The DTF maximum value can be increased by decreasing the frequency step.

Example

If Start Freq. is 300 MHz, Stop Freq. is 600 MHz, the number of points is 10001, and velocity factor is 1, then maximum distance to fault equals to 4996.5 m, i.e. approximately 5 km.



To set the DTF maximum value, use the following softkey in the right menu bar:

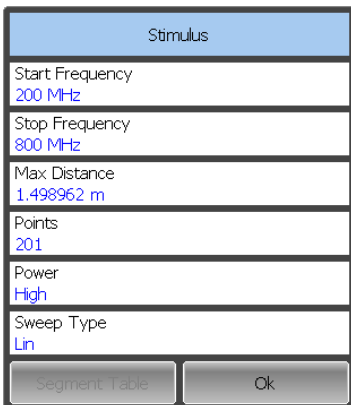

Stimulus

Then select the **Max Distance** field and enter the required value using the on-screen keypad.

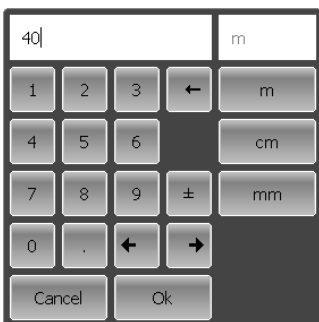

4.7.5 Stimulus Power Setting

The stimulus power level can take two possible values. High output power corresponds to the source signal power of -10 dB/m. Low output power corresponds to -30 dBm.



To enter the power level value, use the following softkey in the right menu bar:

Stimulus	
Start Frequency	200 MHz
Stop Frequency	800 MHz
Max Distance	40 m
Points	201
Power	Low
Sweep Type	Lin
<input type="button" value="Segment Table"/> <input type="button" value="Ok"/>	

Stimulus

Click on the **Power** field to switch between the high and low settings of the power level.

4.7.6 Segment Table Editing

Frequency sweep span can be divided into segments. Each segment has start and stop values of the sweep range, number of points and measurement delay. IF filter and measurement delay can be enabled/disabled by the user.

The types of segment tables are shown below.

Segment Table			
	Start	Stop	Points
1	85 MHz	3 GHz	201
2	3 GHz	4 GHz	51
3	4 GHz	5.4 GHz	101

Segment Table			
Points	IFBW	Delay	
201	300 Hz	0 ms	
51	3 kHz	0 ms	
101	10 kHz	0 ms	

<input type="button" value="Add"/>	<input type="button" value="Delete"/>	<input type="button" value="Save"/>
List IFBW	<input type="button" value="Recall"/>	
List Delay	<input type="button" value="Ok"/>	

<input type="button" value="Add"/>	<input type="button" value="Delete"/>	<input type="button" value="Save"/>
List IFBW	<input type="button" value="Recall"/>	
List Delay	<input type="button" value="Ok"/>	

Each table line determines one segment. The table can contain one or several lines. The number of lines is limited by the aggregate number of all segment points, i.e. 10001



Stimulus	
Start Frequency	200 MHz
Stop Frequency	800 MHz
Max Distance	40 m
Points	201
Power	Low
Sweep Type	Segment
<input type="button" value="Segment Table"/> <input type="button" value="Ok"/>	

Segment Table			
	Start	Stop	Points
1	85 MHz	3 GHz	201
2	3 GHz	4 GHz	51
3	4 GHz	5.4 GHz	101
<input type="button" value="Add"/> <input type="button" value="Delete"/> <input type="button" value="Save"/>			
List IFBW		<input type="button" value="Recall"/>	
List Delay		<input type="button" value="Ok"/>	

To edit the segment table, use the following softkeys in the right menu bar:

Stimulus > Segment Table

Select the segment frequency sweep to make the **Segment Table** softkey available (see section 4.7.1).

To add a segment to the segment table, use

Add

To delete a segment from the table, use

Delete

To enter the segment parameters, move the mouse to the respective box and enter the numerical value. You can navigate the segment table using the «↑», «↓», «←», «→» keys

Note

The adjacent segments cannot overlap in the frequency domain.

Segment Table			
	Start	Stop	Points
1	85 MHz	3 GHz	201
2	3 GHz	4 GHz	51
3	4 GHz	5.4 GHz	101
<div style="display: flex; justify-content: space-around;"> Add Delete Save </div> <div style="display: flex; justify-content: space-between; margin-top: 5px;"> <div style="width: 60%;"> List IFBW ON </div> <div style="width: 20%; text-align: center;">Recall</div> </div> <div style="display: flex; justify-content: space-between; margin-top: 5px;"> <div style="width: 60%;"> List Delay ON </div> <div style="width: 20%; text-align: center;">Ok</div> </div>			

To edit any parameter in the table, double click on the its value field and enter the required value using the on-screen keypad.

To enable/disable the IFBW filter column, click on the **List IFBW** field.

To enable/disable the measurement delay column, click on the **List Delay** field.

The segment table can be saved into *.seg file to a hard disk and later recalled.

To save the segment table, click

Save

To recall the segment table, click

Recall.

4.8 Trigger Setting

The Reflectometer can operate in one of three sweep trigger modes. The trigger mode determines the sweep actuation. The trigger can have the following modes:

- Continuous – a sweep actuation occurs every time after sweep cycle is complete in each channel;
- Single – sweep actuation occurs once, and after the sweep is complete, the trigger turns to hold mode;
- Hold – sweep is stopped, the actuation does not occur.

If more than one channel window is displayed on the screen, a sweep will be actuated in them in succession.



To set the trigger mode, use the following softkey in the right menu bar:

System

Then click on **Trigger** field, select the required mode from the list and complete the setting by

Ok

Close the System dialog by

Ok

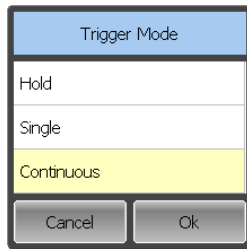

4.9 Measurement Optimizing

4.9.1 IF Bandwidth Setting

The IF bandwidth function allows the user to define the bandwidth of the test receiver. The IF bandwidth can be selected by user from the following values: 100 Hz, 300 Hz, 1 kHz, 3 kHz, 10 kHz and 30 kHz.

The IF bandwidth narrowing allows you to reduce self-noise and widen the dynamic range of the Reflectometer. Also the sweep time will increase. Narrowing of the IF bandwidth by 10 will reduce the receiver noise by 10 dB.

The IF bandwidth should be set for each channel individually. Before you set the IF bandwidth, first activate the channel.

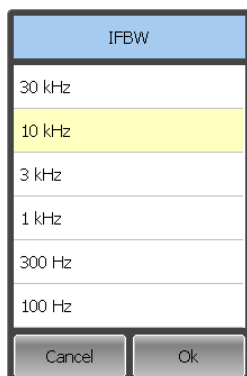
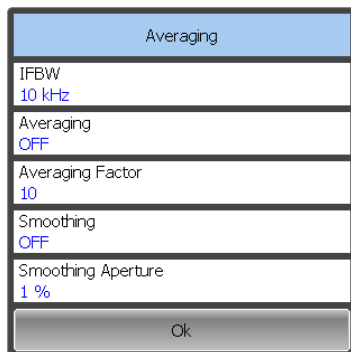

To set the IF bandwidth use the following softkey in the left menu bar:

Average

To set the IF bandwidth, click on **IFBW** field and select the required value from the list.

Complete the setting by

Ok

4.9.2 Averaging Setting

The averaging function is similar to IF bandwidth narrowing, it allows reducing self-noise and widening the dynamic range of the Reflectometer.

The averaging in each measurement point is made over several sweeps according to the exponential window method.

The averaging should be set for each channel individually. Before you set the averaging, first activate the channel.

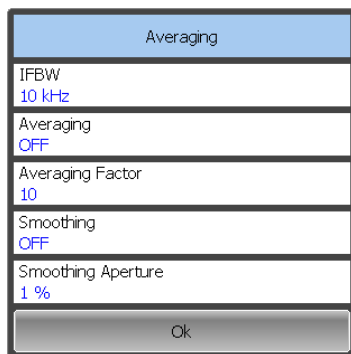

To set the averaging use the following softkey in the left menu bar:

Average

To toggle the averaging function on/off, click on **Average** field.

To set the averaging factor, click on **Averaging Factor** field and enter the required value using the on-screen keypad.

4.9.3 Smoothing Setting

The smoothing of the sweep results is made by averaging the measurement results of adjacent points of the trace determined by the moving aperture. The aperture is set by the user in percent against the total number of the trace points.

The smoothing does not increase the dynamic range of the Reflectometer. It preserves the average level of the trace and reduces the noise bursts.

The smoothing should be set for each trace individually. Before you set the smoothing, first activate the trace.



Averaging	
IFBW	10 kHz
Averaging	OFF
Averaging Factor	10
Smoothing	OFF
Smoothing Aperture	1 %
Ok	

To set the smoothing, use the following softkey in the left menu bar:

Average

To toggle the smoothing function on/off, click on **Smoothing** field.

To set the smoothing aperture, click on **Smoothing Aperture** field and enter the required value using the on-screen keypad.

4.9.4 Max Hold Function

The Max Hold function displays the maximum of any given active measurement instead the real-time data. The held data is displayed as a active trace.

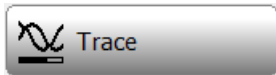

Trace List	
<input type="button" value="Add Trace"/> <input type="button" value="Delete Trace"/>	
No	Format
1	Return Loss
2	Smith Chart
Max Hold	
ON	
Memory Trace	
ON	
Data Math	
OFF	
Ok	

To toggle the Max Hold function on/off, use the following softkeys in the left menu bar:

Trace

And click on **Max Hold** field.

4.10 Cable Specifications

By default, the program does NOT compensate DTF measurements to account for the inherent loss of a cable. However, to make more accurate DTF measurements, the cable loss and velocity factor can be entered using one of the following methods:

- Select a cable type from a list which contains the cable loss in dB/meter and velocity factor;
- Manually enter cable loss and velocity factor for the measurement.

Velocity Factor is a property of the physical material of a cable. A VF of 1.0 corresponds to the speed of light in a vacuum, or the fastest VF possible. A polyethylene dielectric cable has $VF = 0.66$ and a cable with Teflon dielectric has $VF = 0.7$.

Cable Loss is specified in dB/meter. In addition to the length of the cable, loss is also directly proportional to the frequency of the signal that passes through the cable.

4.10.1 Selecting the type of cable



To select the type of cable use the following softkey in the left menu bar:



DTF Settings

Click on **Cable** field, select the required item from the **Cable List** and complete the setting by

Ok

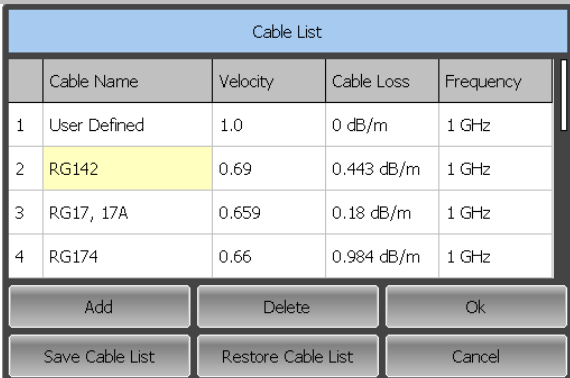

4.10.2 Manually specify Velocity Factor and Cable Loss



DTF Settings	
DTF Unit	Metric, m
Cable	User Defined
Velocity	1
Cable Loss	0 dB/m
Cable Loss Correction	OFF
Kaiser Window	Normal
Gating	
Ok	

To set the parameters of cable, press on the left panel of the program buttons **DTF Settings**.

Click on **Velocity** field to enter the value of velocity factor using the on-screen keypad.

Click on **Cable Loss** field to enter the value of cable loss using the on-screen keypad.

4.10.3 Editing table of cables



DTF Settings	
DTF Unit	Metric, m
Cable	User Defined
Velocity	1
Cable Loss	0 dB/m
Cable Loss Correction	OFF
Kaiser Window	Normal
Gating	
Ok	

To edit table of cables, press on the left panel of the program buttons **DTF Settings**.

Click the left button of the mouse over the field **Cable**.

To add/delete rows in the table, click **Add/Delete**.

Then select the required parameter in the table double click on the corresponding cell.

Enter the required value **Cable Name**, **Velocity**, **Cable Loss** e.c. using the on-screen keypad.

Cable List				
	Cable Name	Velocity	Cable Loss	Frequency
1	User Defined	1.0	0 dB/m	1 GHz
2	RG142	0.69	0.443 dB/m	1 GHz
3	RG17, 17A	0.659	0.18 dB/m	1 GHz
4	RG174	0.66	0.984 dB/m	1 GHz

Add	Delete	Ok
Save Cable List	Restore Cable List	Cancel

To save the table of cables on the drive, click the **Save Cable List** button.

To restore the table cables from the drive, press the **Restore Cable List** button.

5 CALIBRATION AND CALIBRATION KIT

5.1 General Information

5.1.1 Measurement Errors

S-parameter measurements are influenced by various measurement errors, which can be broken down into two categories:

- systematic errors, and
- random errors.

Random errors comprise such errors as noise fluctuations and thermal drift in electronic components, changes in the mechanical dimensions of connectors subject to temperature drift, repeatability of connections. Random errors are unpredictable and hence cannot be estimated and eliminated in calibration. Random errors can be reduced by correct setting of the source power, IF bandwidth narrowing, maintaining constant environment temperature, observance of the Reflectometer warm-up time, careful connector handling, avoidance of cable bending after calibration, and use of the calibrated torque wrench for connection of the Male-Female coaxial RF connectors.

Random errors and related methods of correction are not mentioned further in this section.

Systematic errors are the errors caused by imperfections in the components of the measurement system. Such errors occur repeatedly and their characteristics do not change with time. Systematic errors can be determined and then reduced by performing mathematical correction of the measurement results.

The process of measurement of precision devices with predefined parameters with the purpose of determination of measurement systematic errors is called calibration, and such precision devices are called calibration standards. The most commonly used calibration standards are SHORT, OPEN, and LOAD.

The process of mathematical compensation (numerical reduction) for measurement systematic errors is called an error correction.

5.1.2 Systematic Errors

The systematic measurement errors of vector network analyzers are subdivided into the following categories according to their source:

- Directivity;
- Source match;

- Reflection tracking.

The measurement results before the procedure of error correction has been executed are called uncorrected.

The residual values of the measurement results after the procedure of error correction are called **effective**.

5.1.2.1 Directivity Error

A directivity error (**Ed**) is caused by incomplete separation of the incident signal from the reflected signal by the directional coupler in the source port. In this case part of the incident signal energy comes to the receiver of the reflected signal. Directivity errors do not depend on the characteristics of the DUT and usually have stronger effect in reflection measurements.

5.1.2.2 Source Match Error

A source match error (**Es**) is caused by the mismatch between the source test port and the input of the DUT. In this case part of the signal reflected by the DUT reflects at the test port and again comes into the input of the DUT. The error occurs both in reflection measurement and in transmission measurement. Source match errors depend on the relation between input impedance of the DUT and test port impedance.

Source match errors have strong effect in measurements of a DUT with poor input matching.

5.1.2.3 Reflection Tracking Error

A reflection tracking error (**Er**) is caused by the difference in frequency response between the test receiver and the reference receiver of the test port in reflection measurement.

5.1.3 Error Modeling

Error modeling and method of signal flow graphs are applied to vector network analyzers for analysis of its systematic errors.

5.1.3.1 One-Port Error Model

In reflection measurement only test port of the Reflectometer is used. The signal flow graph of errors for the test port is represented in figure 5.1.

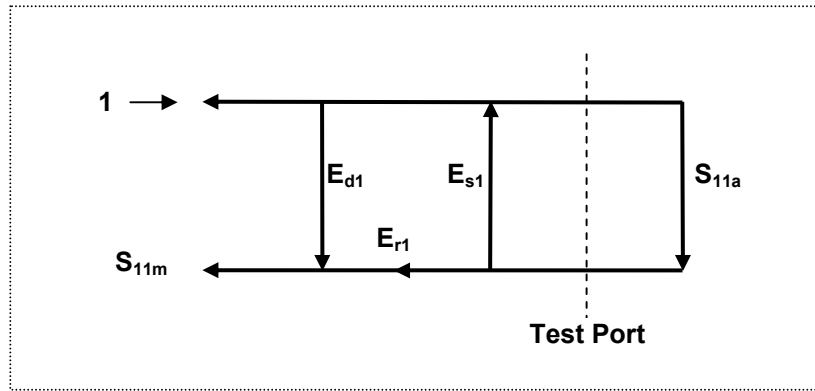

Figure 5.1 One-port error model

Where:

S_{11a} – reflection coefficient true value;

S_{11m} – reflection coefficient measured value.

The measurement result at test port is affected by the following three systematic error terms:

E_{d1} – directivity;

E_{s1} – source match;

E_{r1} – reflection tracking.

For normalization the stimulus value is taken equal to 1. All the values used in the model are complex.

After determining all the three error terms E_{d1} , E_{s1} , E_{r1} for each measurement frequency by means of a full 1-port calibration, it is possible to calculate (mathematically subtract the errors from the measured value S_{11m}) the true value of the reflection coefficient S_{11a} .

There are simplified methods, which eliminate the effect of only one out of the three systematic errors.

5.1.4 Reflectometer Test Port Defining

The test port of the Reflectometer is defined by means of calibration. The test port is a connector accepting a calibration standard in the process of calibration.

A type-N 50 Ω Male connector on the front panel of the Reflectometer will be the test port if the calibration standards are connected directly to it.

Sometimes it is necessary to connect coaxial cable and/or adapter to the connector on the front panel for connection of the DUT with a different connector type. In such cases connect calibration standards to the connector of the cable or adapter.

Figure 5.2 represents two cases of test port defining for the measurement of the DUT. The use of cables and/or adapters does not affect the measurement results if they were integrated into the process of calibration.

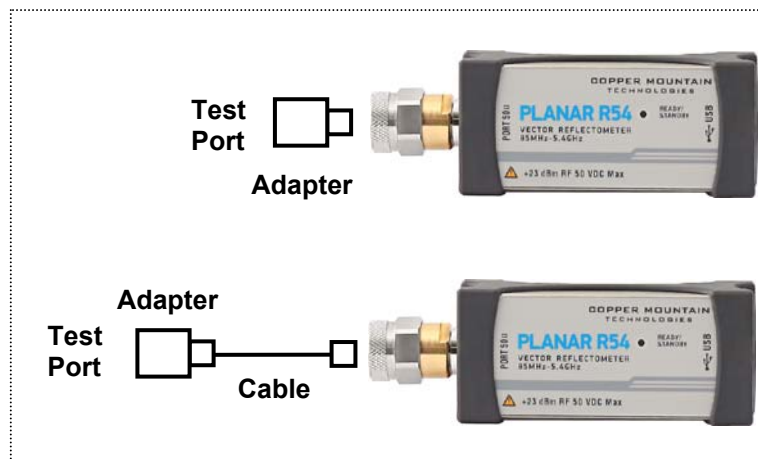

Figure 5.2 Test port defining

In some cases, the term of **calibration plane** is used. Calibration plane is an imaginary plane located at the ends of the connectors, which accept calibration standards during calibration.

5.1.5 Calibration Steps

The process of calibration comprises the following steps:

- Selection of the calibration kit matching the connector type of the test port.
- Selection of a calibration method (see section 5.1.6) is based on the required accuracy of measurements. The calibration method determines what error terms of the model (or all of them) will be compensated.
- Measurement of the standards within a specified frequency range. The number of the measurements depends on the type of calibration.
- The Reflectometer compares the measured parameters of the standards against their predefined values. The difference is used for calculation of the calibration coefficients (systematic errors).
- The table of calibration coefficients is saved into the memory of the Reflectometer and used for error correction of the measured results of any DUT.

Calibration is applied to the Reflectometer as a whole and affects all the channels. This means that one table of calibration coefficients is being stored for all the channels.

5.1.6 Calibration Methods

The Reflectometer supports several methods of calibration. The calibration methods vary by quantity and type of the standards being used, by type of error correction. The table 5.1 represents the overview of the calibration methods.

Table 5.1 Calibration methods

Calibration Method	Parameter	Standards	Errors
Reflection Normalization	S_{11}	SHORT or OPEN	E_{r1}
Expanded Reflection Normalization	S_{11}	SHORT or OPEN LOAD	E_{r1}, E_{d1}
Full One-Port Calibration	S_{11}	SHORT OPEN LOAD	E_{r1}, E_{d1}, E_{s1}

5.1.6.1 Normalization

Normalization is the simplest method of calibration as it involves measurement of only one calibration standard for a measured S-parameter.

1-port (reflection) S-parameter (S_{11}) is calibrated by means of a SHORT or an OPEN standard, estimating reflection tracking error term **Er**.

This method is called normalization because the measured S-parameter at each frequency point is divided (normalized) by the corresponding S-parameter of the calibration standard.

Normalization eliminates frequency-dependent attenuation and phase offset in the measurement circuit, but does not compensate for errors of directivity and mismatch.

5.1.6.2 Expanded Normalization

Expanded normalization involves connection of the following two standards to the test port:

- **SHORT** or **OPEN**, and
- **LOAD**.

Measurement of the two standards allows for estimation of the reflection tracking error term **Er** and directivity error term – **Ed**.

5.1.6.3 Full One-Port Calibration

Full one-port calibration involves connection of the following three standards to the test port:

- **SHORT**,
- **OPEN**,
- **LOAD**.

Measurement of the three standards allows for acquisition of all the three error terms (**Ed**, **Es**, and **Er**) of a one-port model.

5.1.7 Calibration Standards and Calibration Kits

Calibration standards are precision physical devices used for determination of errors in a measurement system.

A calibration kit is a set of calibration standards with a specific type of connector and specific impedance. Calibration kit includes standards of the three following types: **SHORT**, **OPEN**, and **LOAD**.

The characteristics of real calibration standards have deviations from the ideal values. For example, the ideal **SHORT** standard must have reflection coefficient magnitude equal to 1.0 and reflection coefficient phase equal to 180° over the whole frequency range. A real **SHORT** standard has deviations from these values depending on the frequency. To take into account such deviations a **calibration standard model** (in the form of an equivalent circuit with predefined characteristics) is used.

The Reflectometer provides definitions of calibration kits produced by different manufacturers. The user can add the definitions of own calibration kits or modify the predefined kits using the Reflectometer software. Calibration kits editing procedure is described in the section 5.3.

To ensure the required calibration accuracy, select the calibration kit being used in the program menu. The procedure of calibration kit selection is described in section 5.2.1.

5.1.7.1 Types of Calibration Standards

Calibration standard type is a category of physical devices used to define the parameters of the standard. The Reflectometer supports the following types of the calibration standards:

- **OPEN**,
- **SHORT**,
- **LOAD**.

5.1.7.2 Calibration Standard Model

A model of a calibration standard presented as an equivalent circuit is used for determining of S-parameters of the standard. The model is employed for standards of **OPEN**, **SHORT**, and **LOAD** types.

One-port model is used for the standards **OPEN**, **SHORT**, and **LOAD** (See figure 5.3).

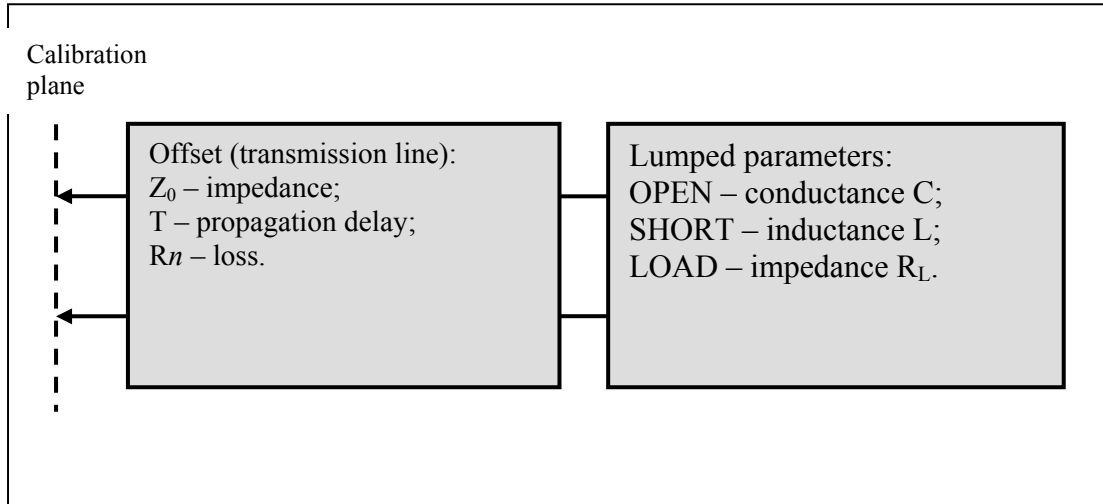

Figure 5.3 One-port standard model

The description of the numeric parameters of an equivalent circuit model of a calibration standard is shown in table 5.2.

Table 5.2 Parameters of the calibration standard equivalent circuit model

Parameter (as in the program)	Parameter Definition
Z₀ (Offset Z0)	It is the offset impedance (of a transmission line) between the calibration plane and the circuit with lumped parameters.
T (Offset Delay)	The offset delay. It is defined as one-way propagation time (in seconds) from the calibration plane to the circuit with lumped parameters or to the other calibration plane. Each standard delay can be measured or mathematically determined by dividing the exact physical length by the propagation velocity.
R_{loss} (Offset Loss)	<p>The offset loss in one-way propagation due to the skin effect. The loss is defined in [Ω/sec] at 1 GHz frequency. The loss in a transmission line is determined by measuring the delay T [sec] and loss L [dB] at 1 GHz frequency. The measured values are used in the following formula:</p> $Rn[\Omega / s] = \frac{L[dB] \cdot Z_0[\Omega]}{4.3429[dB] \cdot T[s]}$
C (C0, C1, C2, C3)	<p>The fringe capacitance of an OPEN standard, which causes a phase offset of the reflection coefficient at high frequencies. The fringe capacitance model is described as a function of frequency, which is a polynomial of the third degree:</p> $C = C_0 + C_1 f + C_2 f^2 + C_3 f^3 \quad , \text{ where}$ <p>f – frequency [Hz]</p> <p>C₀...C₃ – polynomial coefficients</p> <p>Units: C₀[F], C₁[F/Hz], C₂[F/Hz²], C₃[F/Hz³]</p>
L (L0, L1, L2, L3)	<p>The residual inductance of a SHORT standard, which causes a phase offset of the reflection coefficient at high frequencies. The residual inductance model is described as a function of frequency, which is a polynomial of the third degree:</p> $L = L_0 + L_1 f + L_2 f^2 + L_3 f^3 \quad , \text{ where}$ <p>f – frequency [Hz]</p> <p>L₀...L₃ – polynomial coefficients</p> <p>Units: L₀[H], L₁[H/Hz], L₂[H/Hz²], L₃[H/Hz³]</p>

5.2 Calibration Procedures

5.2.1 Calibration Kit Selection

The Reflectometer provides memory space for sixteen calibration kits. The first two items are the calibration kits with indefinite parameters. Next ten items are the kits with manufacturer-defined parameters, available in the Reflectometer by default. The other two items are the empty templates offered for calibration kit definition by the user.

The available calibration kits include the kits of Rosenberger, Agilent and Planar (See table 5.3).

Table 5.3 Calibration kits

No.	Model Number	Calibration Kit Description
1	Not Def 50 Ohm	50 Ω , parameters not defined
2	Not Def 75 Ohm	75 Ω , parameters not defined
3	05CK10A-150 -F-	Rosenberger 05CK10A-150 -F- 50 Ω N-type Female, up to 18 GHz
4	05CK10A-150 -M-	Rosenberger 05CK10A-150 -M- 50 Ω N-type Male, up to до 18 GHz
5	N1.1 Type-N -F-	Planar N1.1 Type-N -F- 50 Ω N-type Female, up to 1.5 GHz
6	N1.1 Type-N -M-	Planar N1.1 Type-N -M- 50 Ω N-type Male, up to 1.5 GHz
7	Agilent 85032B -F-	Agilent 85032B or 85032E, 50 Ω N-type Female, up to 6 GHz
8	Agilent 85032B -M-	Agilent 85032B or 85032E, 50 Ω N-type Male, up to 6 GHz
9	Agilent 85036B -F-	Agilent 85036B, N-type (75 Ω) Female, up to 3 GHz
10	Agilent 85036B -M-	Agilent 85036B, N-type (75 Ω) Male, up to 3 GHz
11	Agilent 85032F -F-	Agilent 85032F, 50 Ω N-type Female, up to 9 GHz
12	Agilent 85032F -M-	Agilent 85032F, 50 Ω N-type Male, up to 9 GHz

13	N611 -F-	Copper Mountain Technologies N611 calibration kits
14	N612 -M-	Copper Mountain Technologies N612 calibration kits
15	Empty	Templates for user-defined calibration kits
16	Empty	Templates for user-defined calibration kits

Note -M- or -F- in the description of the kit denotes the polarity of the calibration standard connector, male or female respectively.

To achieve the specified measurement accuracy, use a calibration kit with known characteristics.

Before starting calibration select in the program the calibration kit being used among the predefined kits, or define a new one and enter its parameters.

Make sure that parameters of your calibration standards correspond to the values stored in the memory of the Reflectometer. If they do not, make the required changes.

The procedure of a calibration kit definition and editing is described in section 5.3.

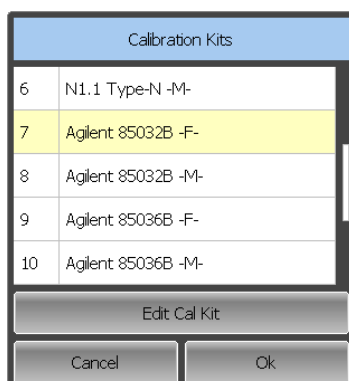
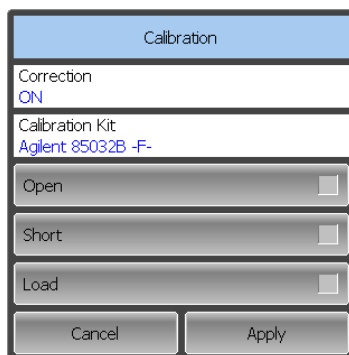

To select the calibration kit, use the following softkey in the left menu bar:

Calibration

The currently selected calibration kit is indicated on the softkey Calibration Kit, e.g. **Agilent 85032B -F-**.

Click this softkey and select the required kit from the list. Complete the setting by

Ok

5.2.2 Reflection Normalization

Reflection normalization is the simplest calibration method used for reflection coefficient measurement (S_{11}). Only one standard (**SHORT** or **OPEN**) is measured (See figure 5.4) in the process of this calibration.

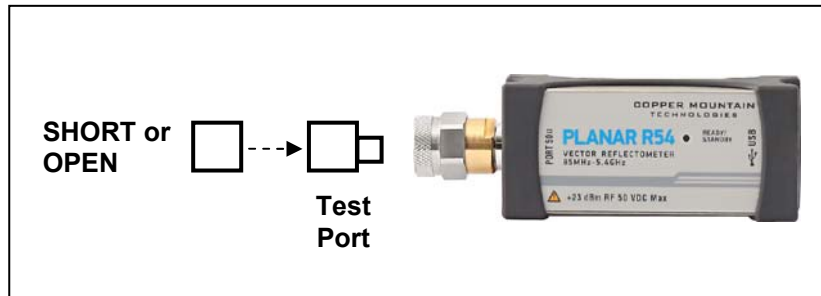
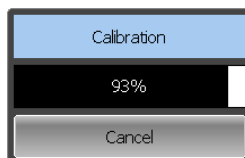

Figure 5.4 Reflection normalization

Before starting calibration perform the following settings: select active channel, set the parameters of the channel (frequency range, IF bandwidth, etc), and select the calibration kit.



To perform reflection normalization, use the following softkey in the left menu bar:

Calibration

Connect an **OPEN** or a **SHORT** standard to the test port as shown in figure 5.4. Perform measurement using **Open** or **Short** softkey respectively.

During the measurement, a pop up window will appear in the channel window. It will have **Calibration** label and will indicate the progress of the measurement. On completion of the measurement, the left part of the **Open** or **Short** softkey will be color highlighted.

Calibration	
Correction	ON
Calibration Kit	Agilent 85032B -F-
Open	<input checked="" type="checkbox"/>
Short	<input type="checkbox"/>
Load	<input type="checkbox"/>
Cancel	Apply

To complete the calibration procedure, click

Apply

This will activate the process of calibration coefficient table calculation and saving it into the memory.

To clear the measurement results of the standards, click

Cancel

This softkey does not cancel the current calibration. To disable the current calibration turn off the error correction function (See section 5.2.4).

Note

You can check the calibration status in the trace status field (See table 5.4).

5.2.3 Full One-Port Calibration

Full one-port calibration is used for reflection coefficient measurement (S_{11}). The three calibration standards (**SHORT**, **OPEN**, and **LOAD**) are measured (See figure 5.5) in the process of this calibration.

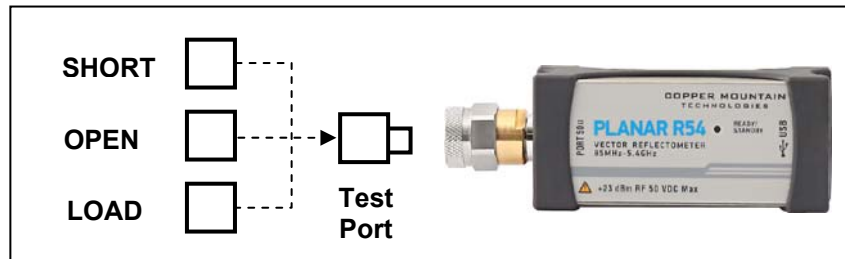

Figure 5.5 Full one-port calibration

Before starting calibration perform the following settings: select active channel, set the parameters of the channel (frequency range, IF bandwidth, etc), and select the calibration kit.



To perform full one-port calibration, use the following softkey in the left menu bar:

Calibration

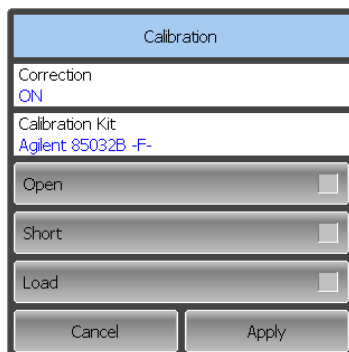

Connect **SHORT**, **OPEN** and **LOAD** standards to the test port in any consequence as shown in figure 5.5. Perform measurements clicking the softkey corresponding to the connected standard, **Open**, **Short** or **Load** respectively.

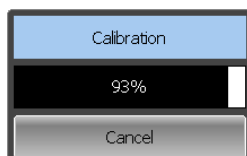

During the measurement, a pop up window will appear in the channel window. It will have **Calibration** label and will indicate the progress of the measurement. On completion of the measurement, the left part of the **Open**, **Short** or **Load** softkey will be color highlighted.

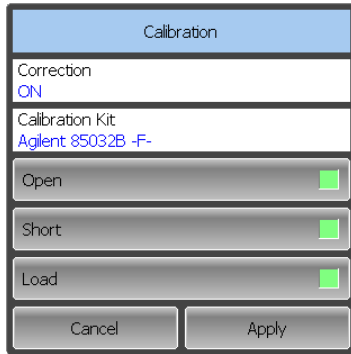

To complete the calibration procedure, click

Apply

This will activate the process of calibration coefficient table calculation and saving it into the memory.

To clear the measurement results of the standards, click

Cancel

This softkey does not cancel the current calibration. To disable the current calibration turn off the error correction function (See section 5.2.4).

Note

You can check the calibration status in the trace status field (See table 5.4).

5.2.4 Error Correction Disabling

This feature allows the user to disable the error correction function.

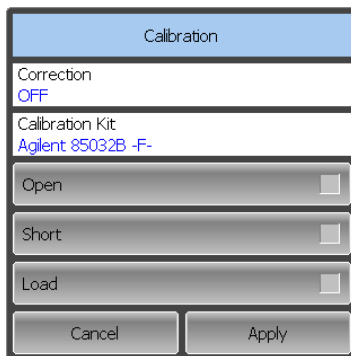

To disable and enable again the error correction function, use the following softkey in the left menu bar:

Calibration

Click on **Correction** field to toggle the on/off settings of the correction state.

Close the dialog by

Apply

When you turn off the error correction function, **Correction Off** message will appear in the program status bar.

Note



5.2.5 Error Correction Status

The error correction status for each individual trace is indicated in the trace status field (See table 5.4). For trace status field description, see section 4.2.2.

Table 5.4 Trace error correction status

Symbols	Definition
RO	OPEN response calibration
RS	SHORT response calibration
F1	Full 1-port calibration

5.2.6 System Impedance Z_0

Z_0 is the system impedance of a measurement path. Normally it is equal to the impedance of the calibration standards, which are used for calibration. The Z_0 value should be specified before calibration, as it is used for calibration coefficient calculations.

Note	Selection of calibration kit automatically determines the system impedance Z_0 in accordance with the value specified for the kit.
------	--

5.2.7 Port Extension

The port extension function enables you to eliminate the fixture (with or without losses) effects on the measurement results. The function virtually extends the test ports moving the calibration plane to the terminals of the DUT (by the length of the fixture). The fixture parameters are defined by the user for each port individually (See figure 5.6).

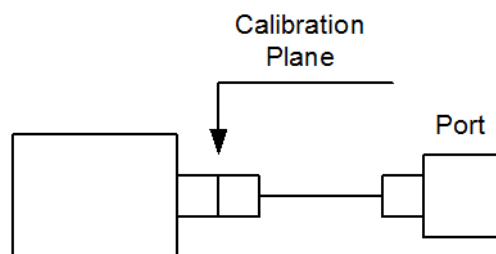

Figure 5.6 Port extension

The phase incursion caused by electrical delay is compensated for, when a lossless fixture needs to be removed:

$$e^{j \cdot 2\pi \cdot f \cdot t}, \text{ where}$$

f - frequency, Hz,

t - electrical delay, sec.

The feature of removing a lossless fixture is similar to the feature of electrical delay setting for a trace (See section 4.6.7), but unlike the latter it applies to all the traces of the channel. It compensates for a fixture length in transmission measurements and for a double fixture length in reflection measurements.

To remove a fixture with losses, the following methods of loss defining (in one, two or three frequency points) are applied:

1. Frequency-independent loss at DC - L_0

$$L(f) = L_0$$

2. Frequency-dependent loss determined by the losses in two frequency points: L_0 at DC, and L_1 at frequency F_1

$$L(f) = L_0 + (L_1 - L_0) \cdot \sqrt{\frac{f}{F_1}}$$

3. Frequency-dependent loss determined by the losses in three frequency points: L_0 at DC, L_1 at frequency F_1 , and L_2 at frequency F_2

$$L(f) = L_0 + (L_1 - L_0) \cdot \left(\frac{f}{F_1}\right)^n,$$

$$n = \frac{\log\left|\frac{L_1}{L_2}\right|}{\log\left|\frac{F_1}{F_2}\right|}$$

The screenshot shows the Calibration menu with the Port Extension option selected. The Port Extension dialog is displayed, showing the following settings:

Port Extension	
Port Extension OFF	
Extension Port 0 ps	
Loss 1 OFF	Loss 2 OFF
Loss 1 0 dB	Loss 2 0 dB
Frequency 1 1 GHz	Frequency 2 1 GHz
Loss at DC 0 dB	
Auto Port Extension	
Ok	

To set the Port Extension, use the following softkeys:

Calibration > Port Extension

Click on **Port Extension** field to toggle the on/off settings of the Port Extension state.

Then select the **Extension Port** field and enter the required value using the on-screen keypad.

Use **Loss at DC** to determinate L_0 .

Use **Loss 1** and **Freq 1** to determinate L_1 and F_1 .

Use **Loss 2** and **Freq 2** to determinate L_2 and F_2 .

Close the dialog by **Ok**

5.2.8 Auto Port Extension

The screenshot shows the Calibration menu with the Auto Port Extension option selected. The Auto Port Extension dialog is displayed, showing the following settings:

Auto Extension Port	
Method Current Span	
Include Loss OFF	
Adjust Mismatch OFF	
Open	<input type="checkbox"/>
Short	<input type="checkbox"/>
Cancel	Apply

To apply the Auto Port Extension, use the following softkey:

Calibration > Port Extension > Auto Port Extension

Click on **Method** field to select method of calculation of extension port (**Current Span**, **User Span** or **Active Marker**).

Click on **Include Loss** or **Adjust Mismatch** field to toggle the on/off status of this settings.

Use softkeys: **Open** or **Short** or **Open** and **Short** to execute a measurement and calculate extension of port.

Close the dialog by **Apply**

5.3 Calibration Kit Management

This section describes how to edit the calibration kit description.

The Reflectometer provides a table for 16 calibration kits. The first twelve kits are the predefined kits. The last two kits are empty templates for adding calibration standards by the user.

A calibration kit redefining can be required to precise the standard parameters to improve the calibration accuracy.

A new user-defined calibration kit adding can be added when a required kit is not included in the list of the predefined kits.

The changes made by the user to the definition of the calibration kits are saved into the calibration kit configuration file in the program working folder. For the saving no additional manipulations are required.

Note	Changes to a predefined calibration kit can be cancelled any time and the initial state will be restored by the Restore softkey in Calibration Kit Editor dialog.
------	---

5.3.1 Calibration Kit Selection for Editing

The calibration kit currently selected for calibration is the kit available for editing. This active calibration kit is selected by the user as described in section 5.2.1.

5.3.2 Calibration Kit Label Editing

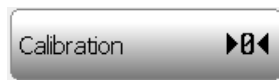

Calibration

Correction
ON

Calibration Kit
Agilent 85032B -F-

Open

Short

Load

Cancel Apply

Calibration Kits

6	N1.1 Type-N -M-
7	Agilent 85032B -F-
8	Agilent 85032B -M-
9	Agilent 85036B -F-
10	Agilent 85036B -M-

Edit Cal Kit

Cancel Ok

To edit the label of a calibration kit, use the following softkeys in the left menu bar:

Calibration > Calibration Kit > Edit Cal Kit

Click on **Calibration Kit Name** field and enter the calibration kit label using the on-screen keypad.

To save the settings and close the dialog, click

Ok

Calibration Kit Editor

Calibration Kit Name
Agilent 85032B -F-

Standart Type	Short	Open	Load	Thru
C0 [e-15 F]	0	119.08	0	0
C1 [e-27 F/Hz]	0	-36.955	0	0
C2 [e-36 F/Hz^2]	0	26.258	0	0
C3 [e-45 F/Hz^3]	0	5.5136	0	0
L0 [e-12 H]	0	0	0	0

Restore Ok

Agilent 85032B -F-

!	@	#	\$	%	^	&	*	()	_	-	+	=	←
~	1	2	3	4	5	6	7	8	9	0	\		Del	
Q	W	E	R	T	Y	U	I	O	P	[]	{	}	
A	S	D	F	G	H	J	K	L	;	:	"	'	/	
Caps	Z	X	C	V	B	N	M	,	.	<	>	?		
En										←	→			

Cancel Ok

5.3.3 Predefined Calibration Kit Restoration

Select the required calibration kit from the list.



Calibration	
Correction	ON
Calibration Kit	Agilent 85032B -F-
Open	<input type="checkbox"/>
Short	<input type="checkbox"/>
Load	<input type="checkbox"/>
<input type="button" value="Cancel"/> <input type="button" value="Apply"/>	

Calibration Kits	
6	N1.1 Type-N -M-
7	Agilent 85032B -F-
8	Agilent 85032B -M-
9	Agilent 85036B -F-
10	Agilent 85036B -M-
<input type="button" value="Edit Cal Kit"/>	
<input type="button" value="Cancel"/> <input type="button" value="Ok"/>	

To cancel the user changes of a predefined calibration kit, use the following softkey:

Calibration > Calibration Kit

Select the required kit from the list and click

Edit Cal Kit

If the kit parameters differ from the predefined ones, Restore softkey becomes available.

To cancel your changes, click

Restore

Close the dialog by

Ok

Calibration Kit Editor				
Calibration Kit Name Agilent 85032B -F-				
Standart Type	Short	Open	Load	Thru
C0 [e-15 F]	0	119.08	0	0
C1 [e-27 F/Hz]	0	-36.955	0	0
C2 [e-36 F/Hz^2]	0	26.258	0	0
C3 [e-45 F/Hz^3]	0	5.5136	0	0
L0 [e-12 H]	0	0	0	0
<input type="button" value="Restore"/>		<input type="button" value="Ok"/>		

5.3.4 Calibration Standard Editing

Calibration Kit Editor				
Calibration Kit Name Agilent 85032B -F-				
Standart Type	Short	Open	Load	Thru
C0 [e-15 F]	0	119.08	0	0
C1 [e-27 F/Hz]	0	-36.955	0	0
C2 [e-36 F/Hz^2]	0	26.258	0	0
C3 [e-45 F/Hz^3]	0	5.5136	0	0
L0 [e-12 H]	0	0	0	0
Restore		Ok		

119.08				
1	2	3	←	
4	5	6		
7	8	9	±	
0	.	←	→	
Cancel		Ok		

To edit the calibration standard parameters, use the following softkeys:

Calibration > Calibration Kit > Edit Cal Kit

Then select the required parameter in the table and double click on the corresponding cell. Enter the required value using the on-screen keypad.

C0 [e-15 F]
C1 [e-27 F/Hz]
C2 [e-36 F/Hz^2]
C3 [e-45 F/Hz^3]

For an OPEN standard, the values fringe capacitance of the OPEN model are specified. This model is described by the following polynomial of the third order:

$$C = C_0 + C_1 f + C_2 f^2 + C_3 f^3, \text{ where}$$

f: frequency [Hz]

$C_0 \dots C_3$ – polynomial coefficients

L0 [e-12 H]
L1 [e-24 H/Hz]
L2 [e-33 H/Hz^2]
L3 [e-42 H/Hz^3]

For a SHORT standard, the values of the residual inductance of the SHORT model are specified. This model is described by the following polynomial of the third order:

$$L = L_0 + L_1 f + L_2 f^2 + L_3 f^3, \text{ where}$$

f: frequency [Hz]

$L_0 \dots L_3$ – polynomial coefficients

Offset Delay [ps]
Offset Z0 [Ohm]
Offset Loss [GOhm/s]

The parameters of the transmission line of the standard model are specified for all the types of the standards.

- Offset delay value in one direction (s);
 - Offset wave impedance value (Ω);
 - Offset loss value (Ω/s).
-

5.3.5 Calibration Standard Defining by S-Parameter File

Parameters of a calibration standard can be set from an S-parameter file in Touchstone format.



To set the calibration standard parameters by S-parameter file, use the following softkeys:

Calibration > Calibration Kit > Edit Cal Kit

In the Calibration Kit Editor dialog select the Touchstone file row. Then select the cell with the required standard and double click on it. Dialog for file selection will appear. For this dialog description, see section 7.1.2.

Select Use Database Std row in the table and the the cell with the required standard type. Double click on the cell will toggle the on/off status.

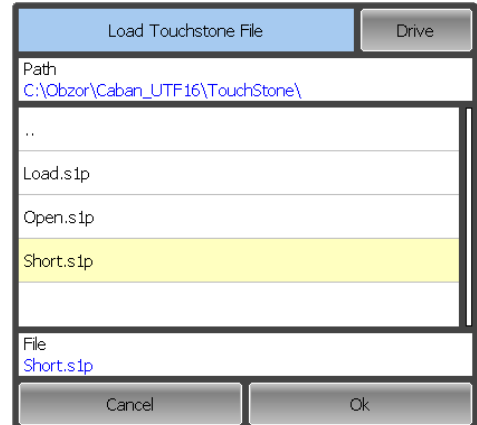
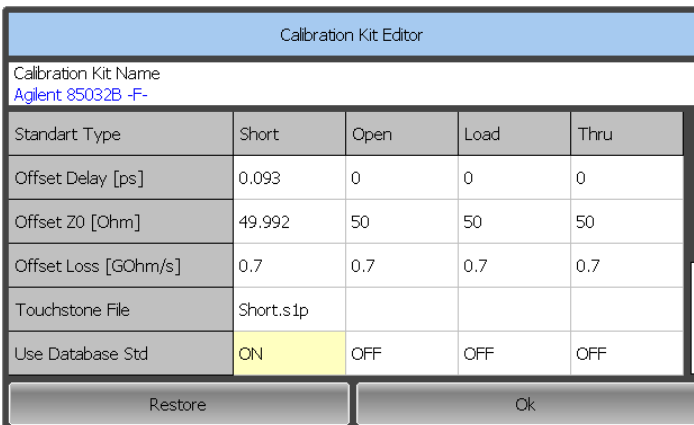
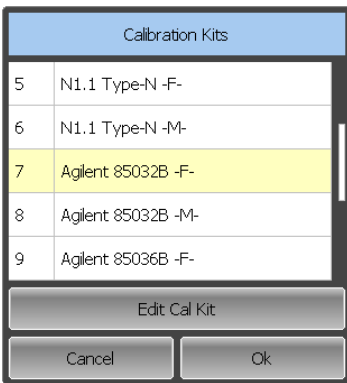

Note

If a file in the Touchstone format is not uploaded or its format is improper, it will be impossible to use the S-parameter file to define the calibration standard.

5.4 Automatic Calibration Module

Automatic calibration module (ACM) is a special device, which allows for automating of the process of calibration. ACM is shown in figure 5.7.



Figure 5.7 Automatic Calibration Module

ACM offers the following advantages over the traditional SOLT calibration, which uses a mechanical calibration kit:

- Reduces the number of connections of standards. Instead of connecting seven standards, it requires connecting only two ACM connectors;
- Reduces the calibration time;
- Reduces human error probability;
- Provides higher accuracy potentially.

ACM has two RF connectors for connection to the Analyzer test ports and a USB connector for control. ACM contains electronic switches, which switch between different reflection and transmission impedance states, as well as memory, which stores precise S-parameters of these impedance states.

After you connect the ACM to the Analyzer, the Analyzer software performs the calibration procedure automatically, i.e. switches between different ACM states, measures them, and computes calibration coefficients using the data stored in the ACM memory.

5.4.1 Automatic Calibration Module Features

Calibration Types:

ACM allows the Analyzer software to perform 1-Path two-port or full one-port calibrations with the click of a button. We recommend that you terminate the unusable ACM port with a load while performing one-port calibration.

Characterization:

Characterization is a table of S-parameters of all the states of the ACM switches, stored in the ACM memory. There are two types of characterization: user characterization and factory characterization. ACM has two memory sections. The first one is writeprotected and contains factory characterization. The second memory section allows you to store up to three user characterizations. Before calibration you can select the factory characterization or any of the user characterizations stored in the ACM memory. The user characterization option is provided for saving new S-parameters of the ACM after connecting adapters to the ACM ports.

Automatic Orientation:

Orientation means relating the ACM ports to the test ports of the Analyzer. While the Analyzer test ports are indicated by numbers, the ACM ports are indicated by letters A and B.

Orientation is defined either manually by the user, or automatically. The user is to select the manual or automatic orientation method. In case of automatic orientation, the Analyzer software determines the ACM orientation each time prior to its calibration or characterization.

Thermal Compensation:

The most accurate calibration can be achieved if the ACM temperature is equal to the temperature, at which it was characterized. When this temperature changes, certain ACM state parameters may deviate from the parameters stored in the memory. This results in reduction of the ACM calibration accuracy.

To compensate for the thermal error, the ACM features thermal compensation function. Thermal compensation is a software function of the ACM S-parameter correction based on its temperature dependence and the data from the temperature sensor inside the ACM. The temperature dependence of each ACM is determined at the factory and saved into its memory.

The function of thermal compensation can be enabled or disabled by the user.

5.4.2 Automatic Calibration Procedure

Before calibrating the Analyzer with ACM, perform some settings, i.e. activate a channel and set channel parameters (frequency range, IF bandwidth, etc).

Connect the ACM to the Analyzer test ports, and connect the USB port of the ACM to the USB port of the computer.



Calibration	
Correction	ON
Calibration Kit	Not defined 50 Ohm
Open	<input type="checkbox"/>
Short	<input type="checkbox"/>
Load	<input type="checkbox"/>
Port Extension	
Autocalibration	
Cancel	Apply

Autocalibration	
AutoCal Module	SC6000 No13096105
Characterization	Factory
Orientation	AUTO
Termocompensation	OFF
Confidence Check	
Characterization Info	
Cancel	Calibrate

To start automatic calibration, use the following softkeys:

Calibration > Autocalibration->Calibrate

Select manual or automatic orientation of the ACM using **Orientation** field. It is recommended to select **AUTO** orientation.

Enable or disable the thermal compensation using **Termocompensation** field.

To display detailed information on characterization, use **Characterization Info** softkey.

6 MEASUREMENT DATA ANALYSIS

6.1 Markers

A marker is a tool for numerical readout of a stimulus value and a measured parameter value in a specific point on the trace. You can activate up to 16 markers on each trace. See a trace with two markers in figure 6.1.

The markers allow the user to perform the following tasks:

- Reading absolute values of a stimulus and a measured parameter in selected points on the trace;
- Reading relative values of a stimulus and a measured parameter related to the reference point;
- Search for minimum, maximum, peak and pre-defined values on the trace;
- Determining trace parameters (statistics, bandwidth, etc).

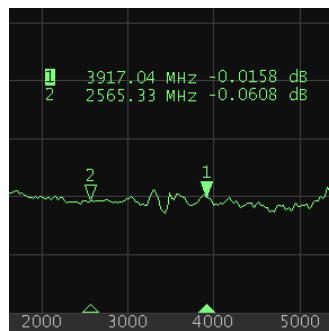

Figure 6.1

Markers can have the following indicators:

1 ▼	symbol and number of the active marker on a trace,
2 ▽	symbol and number of the inactive marker on a trace,
▲	symbol of the active marker on a stimulus axis,
△	symbol of the inactive marker on a stimulus axis.

The marker data field contains the marker number, stimulus value, and the measured parameter value. The number of the active marker is highlighted in inverse color.

The marker data field contents vary depending on the display format (rectangular or circular).

In rectangular format, the marker shows the measurement parameter value plotted along Y-axis in the active format (See table 4.6).

In circular format, Smith chart ($R+jX$), the marker shows the following values:

- Resistance (Ω);
- Reactance (Ω);
- Equivalent capacitance or inductance (F/H).

6.1.1 Marker Adding

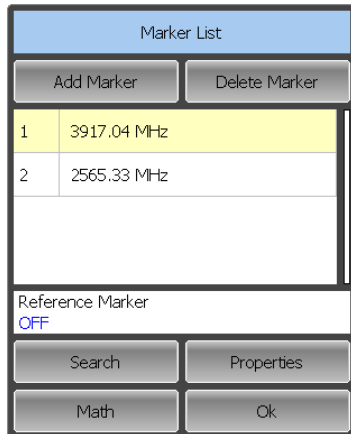

To enable a new marker, use the following softkeys:

Marker > Add Marker

Note

The new marker appears as the active marker in the middle of the stimulus axis.

6.1.2 Marker Deleting



To delete an active marker, use the following softkeys:

Marker > Delete Marker

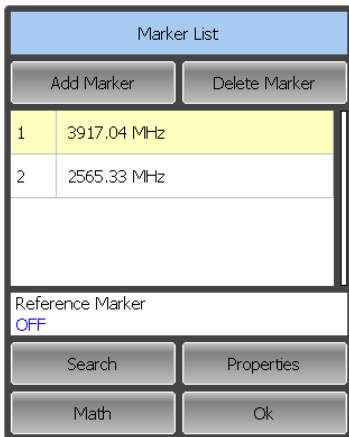
**Note**

The active marker is highlighted in the Marker List dialog.

6.1.3 Marker Stimulus Value Setting

Before you set the marker stimulus value, you need to select the active marker.

You can set the stimulus value by entering the numerical value from the keyboard or by dragging the marker using the mouse. Drag-and-drop operation is described in section 4.3.6.

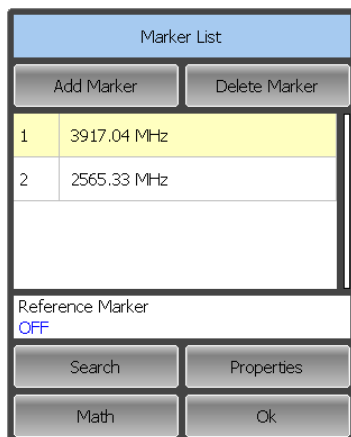

To set the marker stimulus value, use the following softkey:

Marker

Select a required marker from the list.

Double click on the marker stimulus value in the table, and enter the stimulus value using the on-screen keypad.

Complete the setting by

Ok



Note

To enter the stimulus numerical value in the marker data field, you have to click on it.

6.1.4 Marker Activating



To activate a marker , use the softkey:

Marker

In the **Marker List** dialog click on the marker number to activate it.

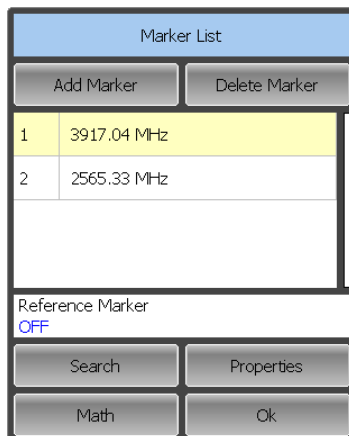

Note

You can activate a marker on the trace by clicking on it.

6.1.5 Reference Marker Feature

Reference marker feature allows the user to view the data relative to the reference marker. Other marker readings are represented as delta relative to the reference marker. The reference marker shows the absolute data. The reference marker is indicated with R symbol instead of a number (See figure 6.2). Enabling of a reference marker turns all the other markers to relative display mode.

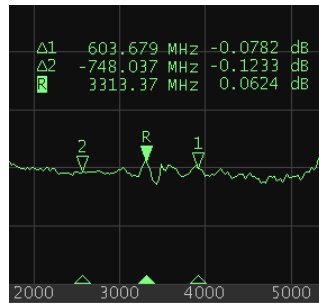

Figure 6.2

Reference marker can be indicated on the trace as follows:

R ▼	symbol of the active reference marker on a trace;
R ▽	symbol of the inactive reference marker on a trace.

The reference marker displays the stimulus and measurement absolute values. All the rest of the markers display the relative values:

- stimulus value — difference between the absolute stimulus values of this marker and the reference marker;
- measured value — difference between the absolute measurement values of this marker and the reference marker.

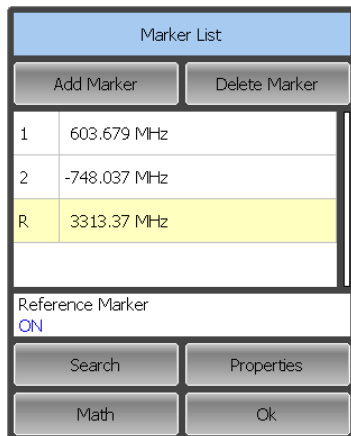

To enable/disable the reference marker feature, use the softkey:

Marker

Click on the **Ref. Marker** status field to toggle the status of the reference marker. The reference marker will be added/deleted to/from the marker list and the trace.

6.1.6 Marker Properties

6.1.6.1 Marker Coupling Feature

The marker coupling feature enables/disables dependence of the markers of the same numbers on different traces. If the feature is turned on, the coupled markers (markers with same numbers) will move along X-axis synchronously on all the traces. If the coupling feature is off, the position of the markers with same numbers along X-axis will be independent (See figure 6.3).

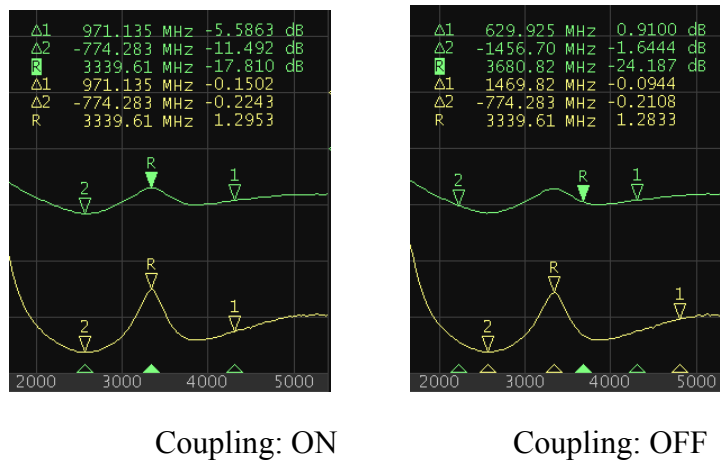

Figure 6.3 Marker coupling feature

Marker

Marker List	
Add Marker	Delete Marker
1	603.679 MHz
2	-748.037 MHz
R	3313.37 MHz
Reference Marker	
ON	
Search	Properties
Math	OK

To enable/disable the marker coupling feature, use the following softkeys:

Marker > Properties

In the **Marker Properties** dialog click on the **Marker Couple** value field to toggle between the values.

Close the dialog by

Ok



6.1.6.2 Marker Value Indication Capacity

By default, the marker stimulus values are displayed with 8 decimal digits and marker response values are displayed with 5 decimal digits. The user can change these settings. The stimulus range is from 5 to 10 decimal digits, and response range is from 3 to 8 decimal digits.



To set the marker value indication capacity, use the following softkeys:

Marker > Properties

Click on the **Stimulus Digits** field to enter the number of stimulus decimal digits.

Click on the **Response Digits** field to enter the number of response decimal digits.

Close the dialog by

Ok

6.1.6.3 Multi Marker Data Display

If several traces are displayed in one channel window, by default only the active trace marker data are displayed on the screen. The user can enable displaying marker data of all traces simultaneously. The markers of different traces will be distinguished by color. Each marker will have the same color with its trace.



To enable/disable the multi marker data display, use the softkeys:

Marker > Properties

Click in the **Active Only** field.

Marker Properties	
Stimulus Digits	6
Response Digits	5
Active Only	OFF
Marker Couple	OFF
Align	Vertical
Ok	

The **OFF** value stands for multi marker data display mode.

Note

When multi marker data display is enabled, arrange the marker data on the screen to avoid data overlapping.

6.1.6.4 Marker Data Alignment

By default marker data are arranged individually for each trace. The user can enable marker data alignment on the screen. Such alignment cancels individual arrangement of marker data of different traces. The marker data of all succeeding traces are aligned against the first trace.

There are two types of alignment:

- Vertical – marker data of different traces are arranged one under another;
- Horizontal – marker data of different traces are arranged in a line;

Marker Properties	
Stimulus Digits	6
Response Digits	5
Active Only	OFF
Marker Couple	OFF
Align	Vertical
Ok	

To enable marker data alignment, use the following sofkeys:

Markers > Properties

Click in the Align parameter value field. In the Align dialog, double click on the alignment type.

Close the dialog by clicking

OK

Align	
Vertical	<input type="radio"/>
Horizontal	<input type="radio"/>
OFF	<input checked="" type="radio"/>
Cancel	Ok

6.1.7 Marker Position Search Functions

Marker position search function enables you to find on a trace the following values:

- maximum value;
- minimum value;
- peak value;
- target level.

Before you start the search, first activate the marker.

6.1.7.1 Search for Maximum and Minimum

Maximum and minimum search functions enable you to determine the maximum and minimum values of the measured parameter and move the marker to these positions on the trace (See figure 6.4).

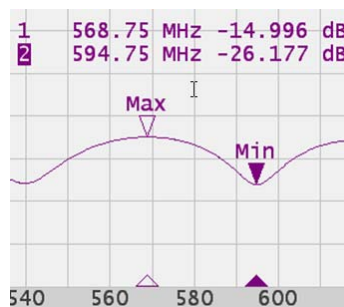
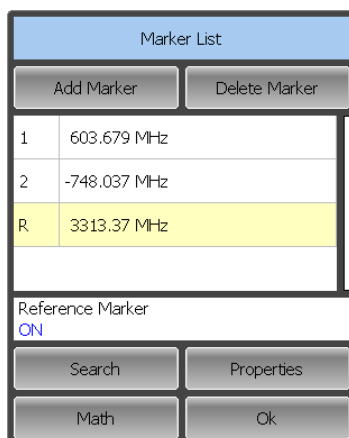

Figure 6.4 Maximum and minimum search



To find the maximum or minimum values on a trace, use the following softkeys:

Marker > Search > Search Min

Marker > Search > Search Max

The last search type applied to the marker is indicated in the **Search Type** field of the Search dialog.

Marker Search	
Search Type	Maximum
Tracking	OFF
Search Range	OFF
Search Start	85,000 MHz
Search Stop	5400,00 MHz
Search Max	Search Min
Search Peak	Search Target
Ok	

6.1.7.2 Search for Peak

Peak search function enables you to determine the peak value of the measured parameter and move the marker to this position on the trace (See figure 6.5).

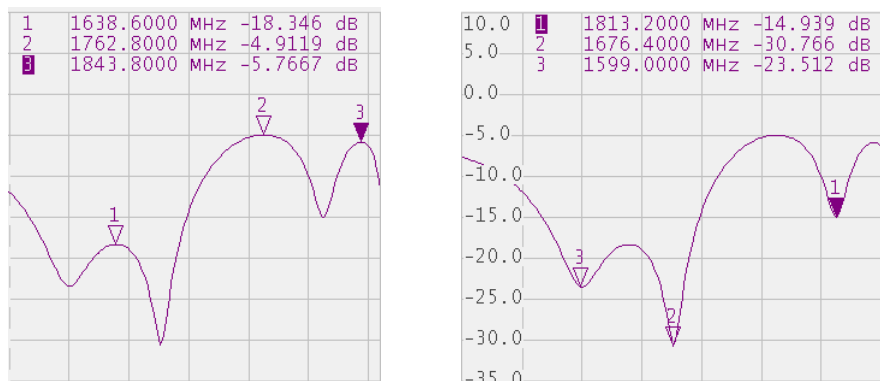

Figure 6.5 Positive and negative peaks

Peak is called positive if the value in the peak is greater than the values of the adjacent points.

Peak is called negative if the value in the peak is smaller than the values of the adjacent points.

Peak excursion is the smallest of the absolute differences between the response values in the peak point and the two adjoining peaks of the opposite polarity.

The peak search is executed only for the peaks meeting the following two conditions:

- The peaks must have the polarity (positive, negative, or both) specified by the user;
- The peaks must have the peak deviation not less than the value assigned by the user.

The following options of the peak search are available:

- Search for nearest peak;
- Search for greatest peak;
- Search for left peak;
- Search for right peak.

The nearest peak is the peak, which is located nearest to the current position of the marker along the stimulus axis.

The greatest peak is a peak with maximum or minimum value, depending on the current polarity settings of the peak.

Note

The search for the greatest peak is deferent from the search for maximum or minimum as the peak cannot be located in the limiting points of the trace even if these points have maximum or minimum values.



Marker List	
Add Marker	Delete Marker
1	603.679 MHz
2	-748.037 MHz
R	3313.37 MHz
Reference Marker ON	
Search	Properties
Math	Ok

Marker Search	
Search Type	Maximum
Tracking	OFF
Search Range	OFF
Search Start	85,000 MHz
Search Stop	5400,00 MHz
Search Max	Search Min
Search Peak	Search Target
Ok	

Search Peak	
Peak Excursion	0.1000 dB
Peak Polarity	Positive
Search Peak	
Max Peak	
Peak Left	
Peak Right	
Ok	

Peak Polarity	
Positive	
Negative	
Both	
Cancel	Ok

To search for the peak value, use the following softkeys:

Marker > Search > Search Peak

Depending on the search function, select one of the following softkeys:

Search Peak

Max Peak

Peak Left

Peak Right

Set the peak excursion value if necessary. Click on the **Peak Excursion** field and set the required peak polarity by a click in the **Peak Polarity** field.

6.1.7.3 Search for Target Level

Target level search function enables you to locate the marker with the given (target) level of the measured parameter (See figure 6.6).

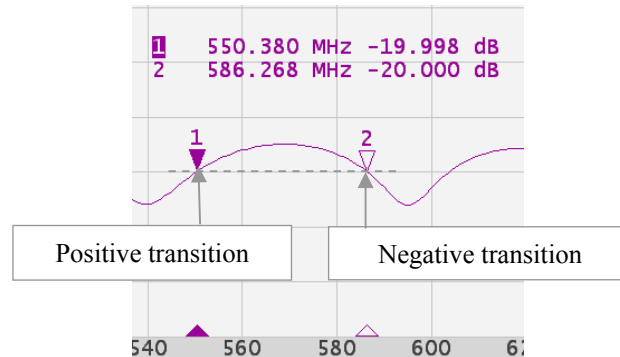

Figure 6.6 Target level search

The trace can have two types of transition in the points where the target level crosses the trace:

- transition type is positive if the function derivative (trace slope) is positive at the intersection point with the target level;
- transition type is negative if the function derivative (trace slope) is negative at the intersection point with the target level.

The target level search is executed only for the intersection points, which have the specific transition polarity selected by the user (positive, negative, or both).

The following options of the target level search are available:

- Search for nearest target;
- Search for left target;
- Search for right target.



Marker List	
Add Marker	Delete Marker
1	603.679 MHz
2	-748.037 MHz
R	3313.37 MHz
Reference Marker ON	
Search	Properties
Math	Ok

Marker Search	
Search Type	Maximum
Tracking	OFF
Search Range	OFF
Search Start	85,0000 MHz
Search Stop	5400,00 MHz
Search Max	Search Min
Search Peak	Search Target
Ok	

Search Target	
Target Value	-20.000 dB
Target Transition	Both
Search Target	
Target Left	
Target Right	
Ok	

To search for target level value, use the following softkeys:

Marker > Search > Search Target

Depending on the search function, select one of the following softkeys:

Search Target

Target Left

Target Right

To set the target level value, click on the **Target Value** field and enter the value using the on-screen keypad.

To set the transition type, click on the **Target Transition** field.

6.1.7.4 Search Tracking

The marker position search function by default can be initiated by any search softkey. Search tracking mode allows you to perform continuous marker position search, until this mode is disabled.

Marker Search	
Search Type	Maximum
Tracking	ON
Search Range	OFF
Search Start	85.0000 MHz
Search Stop	5400.00 MHz
Search Max	Search Min
Search Peak	Search Target
Ok	

To enable/disable search tracking mode, use the following softkeys:

Marker > Search

Click on the **Tracking** field to enable/disable the search tracking mode.

Tracking will be performed for that marker search type, which was the last one to be searched. The marker search type will be indicated in the **Search Type** field.

6.1.7.5 Search Range

The user can set the search range for the marker position search by setting the stimulus limits.

Marker Search	
Search Type	Maximum
Tracking	ON
Search Range	ON
Search Start	1500.00 MHz
Search Stop	3500.00 MHz
Search Max	Search Min
Search Peak	Search Target
Ok	

To enable/disable the search range, use the following softkeys:

Marker > Search

Click on the **Search Range** field to enable/disable the search range.

To enter the search range parameters, click on the **Search Start** or **Search Stop** field and enter the stimulus value using the on-screen keypad.

6.1.8 Marker Math Functions

Marker math functions are the functions, which use markers for calculating of various trace characteristics. Four marker math functions are available:

- Statistics;
- Bandwidth Search;
- Flatness;
- RF Filter.

6.1.8.1 Trace Statistics

The trace statistics feature allows the user to determine and view such trace parameters as mean, standard deviation, and peak-to-peak. The trace statistics range can be defined by two markers (See figure 6.7).

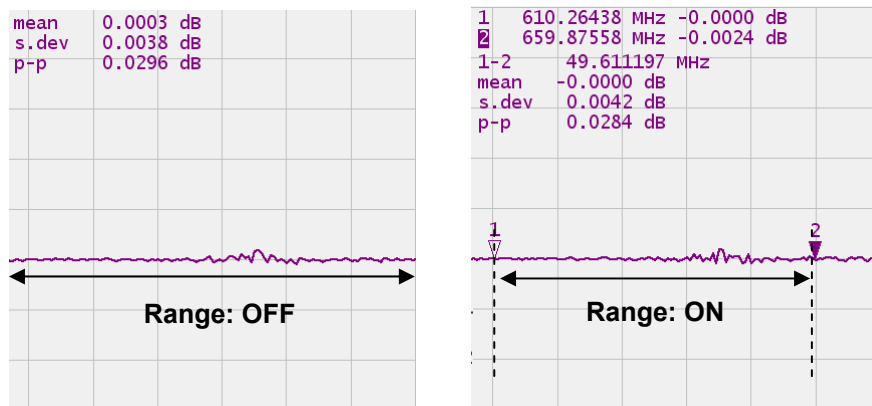

Figure 6.7 Trace statistics

Table 6.1 Statistics parameters

Symbol	Definition	Formula
mean	Arithmetic mean	$M = \frac{1}{N} \cdot \sum_{i=1}^N x_i$
s.dev	Standard deviation	$\sqrt{\frac{1}{N-1} \cdot \sum_{i=1}^N (x_i - M)^2}$
p-p	Peak-to-Peak: difference between the maximum and minimum values	Max – Min



To enable/disable trace statistics function, use the following softkeys:

Markers > Math

Select the **Statistics** tab and click on the **Statistics** field to toggle between the on/off status.

To enable/disable statistics range feature, click on the **Statistics Range** field to toggle between the on/off status.

The statistics range is set by two markers. If there

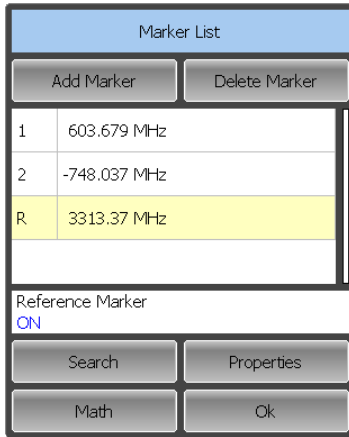

Marker List

Add Marker Delete Marker

1	603.679 MHz
2	-748.037 MHz
R	3313.37 MHz

Reference Marker
ON

Search Properties

Math Ok

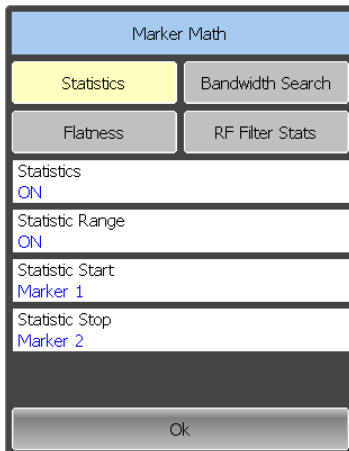

Marker Math

Statistics Bandwidth Search

Flatness RF Filter Stats

Statistics
ON

Statistic Range
ON

Statistic Start
Marker 1

Statistic Stop
Marker 2

Ok

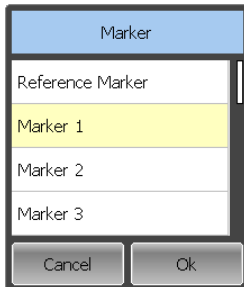

Marker

Reference Marker

Marker 1

Marker 2

Marker 3

Cancel Ok

are no markers in the list, add two markers. Marker adding operation is described in section 6.1.1.

Click on the **Statistic Start** or **Statistic Stop** field and select the required marker numbers from the list.

6.1.8.2 Flatness

The flatness function allows the user to determine and view the following trace parameters: gain, slope, and flatness. The user sets two markers to specify the flatness search range (See figure 6.8).

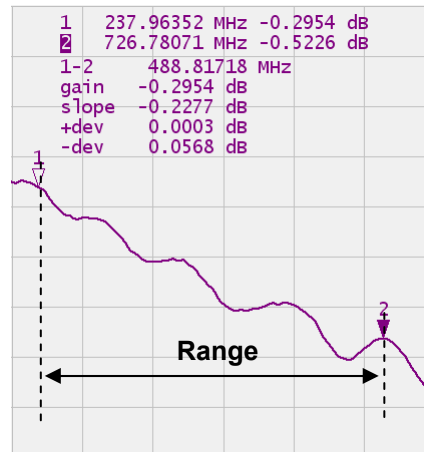

Figure 6.8 Flatness

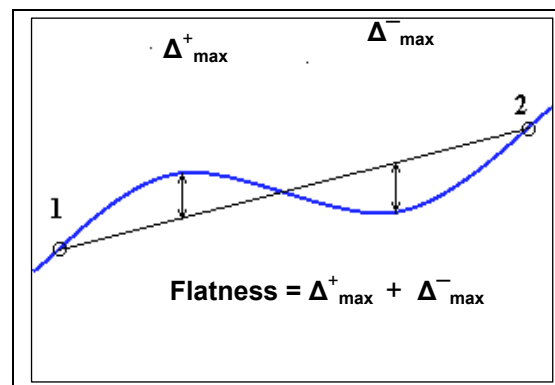
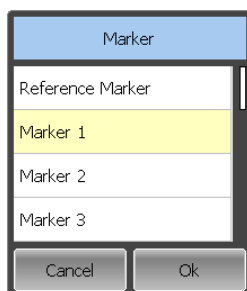
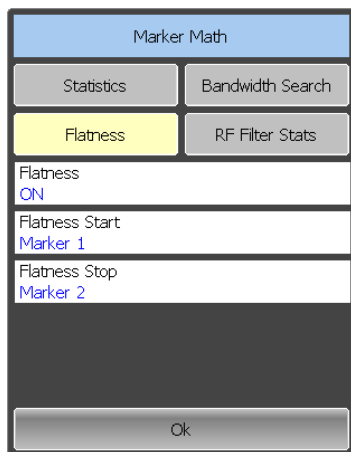
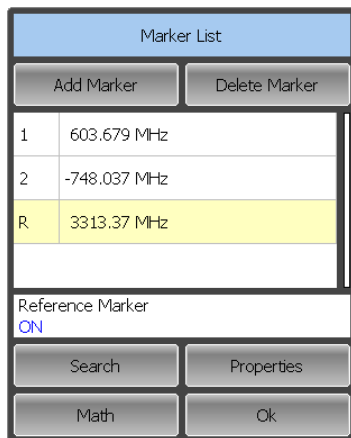

Figure 6.9 Flatness parameters determination

Table 6.2 Flatness parameters

Parameter Description	Symbol	Definition
Gain	gain	Marker 1 value
Slope	slope	Difference between marker 2 and marker 1 values.
Flatness	+dev -dev	Sum of “positive” and “negative” peaks of the trace, which are measured from the line connecting marker 1 and marker 2 (See figure 6.9).



To enable/disable the flatness search function, use the following softkeys:

Markers > Math

Select the **Flatness** tab and click on the **Flatness** field to toggle between the on/off status.

Flatness range is set by two markers. Add two markers, if there are no markers in the list. Marker adding procedure is described in section 6.1.1.

Click on the **Flatness Start** or **Flatness Stop** field and select the required marker numbers from the list.

6.2 Memory Trace Function

For each data trace displayed on the screen a so-called memory trace can be created. Memory traces can be saved for each data trace. The memory trace is displayed in the same color as the main data trace, but its brightness is lower.

The memory trace is a data trace saved into the memory. It is created from the current measurement when the user is clicking the corresponding softkey or when the current sweep is completed. After that, the two traces become simultaneously displayed on the screen – the data trace and the memory trace.

The memory traces have the same format as the data traces. Changing data trace format will change memory trace format.

6.2.1 Saving Trace into Memory

The memory trace function can be applied to the individual traces of the channel. Before you enable this function, first activate the trace.

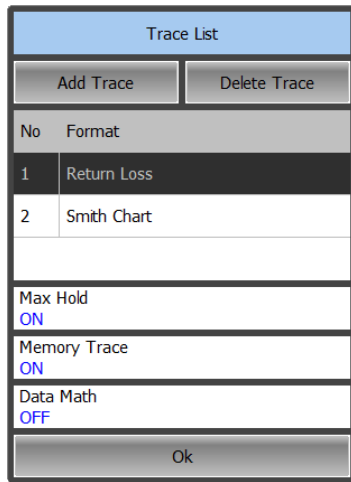

Click the following softkey in the left-hand menu bar:

Trace

The active trace will be highlighted in the list. If necessary, select the required trace by clicking on it.

To enable trace saving into memory, click on the **Memory Trace** field to set the value to ON.

The data will be saved into memory immediately.

6.2.2 Memory Trace Deleting

The memory trace deleting can be applied to the individual traces of the channel. Before you enable this function you have to activate the trace.



Click the **Trace** softkey in the right menu bar

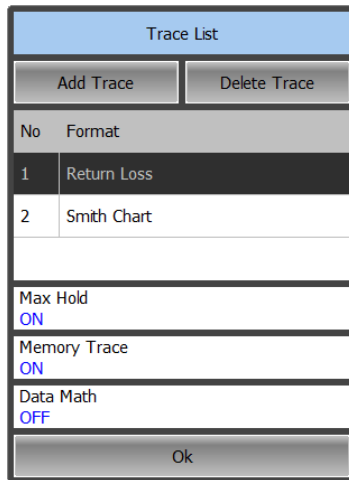

To delete a memory trace, click in the **Memory Trace** parameter value field. The **Memory Trace** parameter value will change to **OFF**.

6.2.3 Memory Trace Math

The memory trace can be used for math operations with the data trace. The resulting trace of such an operation will replace the data trace. The math operations with memory and data traces are performed in complex values. The following four math operations are available:

- Division of data trace by memory trace. The trace status bar indicates : **D/M**.
- Multiplication of data trace by memory trace. Trace status bar indicates: **D*M**.
- Subtraction of memory trace from data trace. Trace status bar indicates: **D-M**.
- Addition of data trace and memory trace. Trace status bar indicates: **D+M**.

The memory trace function can be applied to individual traces of the channel. Before you enable this function, first activate the trace.



Click the following softkey in the right menu bar:

Trace

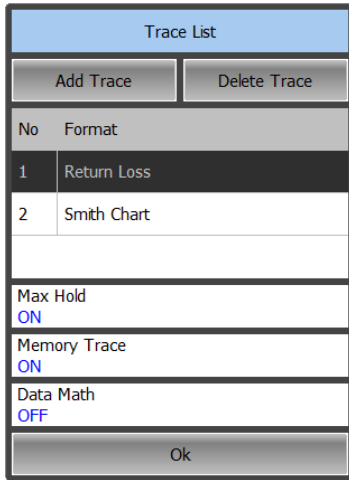

The Trace List dialog box has a blue header with the text "Trace List". Below the header are two buttons: "Add Trace" and "Delete Trace". The main area contains a table with two columns: "No" and "Format".

No	Format
1	Return Loss
2	Smith Chart

Below the table are three rows of settings:

- Max Hold: ON
- Memory Trace: ON
- Data Math: OFF

At the bottom of the dialog is an "Ok" button.

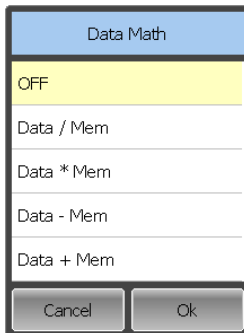

The Data Math dialog box has a blue header with the text "Data Math". The main area contains a list of options:

- OFF (highlighted in yellow)
- Data / Mem
- Data * Mem
- Data - Mem
- Data + Mem

At the bottom of the dialog are two buttons: "Cancel" and "Ok".

Click the **Data Math** field.

In the **Data Math** dialog select the math operation type for the current data traces and memory traces.

Close the dialog by

Ok

The result of math operation will be displayed in the form of current data traces.

6.3 Fixture Simulation

The fixture simulation function enables you to emulate the measurement conditions other than those of the real setup. The following conditions can be simulated:

- Port Z conversion;
- De-embedding;
- Embedding.

Before starting the fixture simulation, first activate the channel. The simulation function will affect all the traces of the channel.



To open the fixture simulation menu, use the following softkeys:

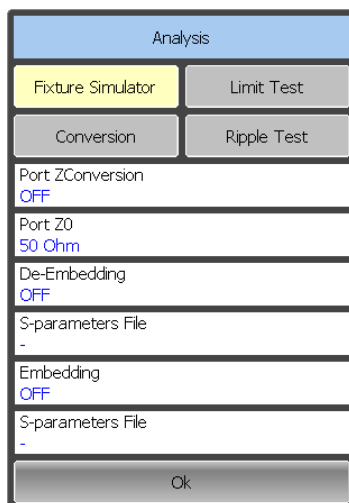

Analysis > Fixture Simulator

6.3.1 Port Z Conversion

Port Z conversion is a function of transformation of the S-parameters measured during port wave impedance change simulation.

Note

The value of the test port impedance is defined in the process of calibration. It is determined by the characteristic impedance of the calibration kit.

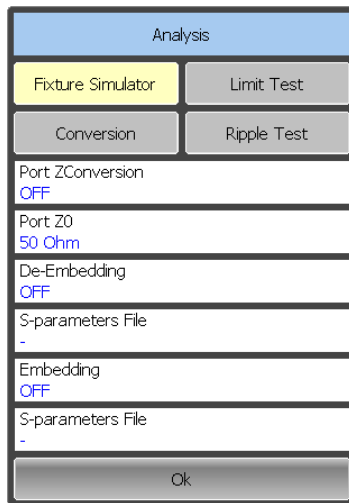

To open the fixture simulation menu, use the following softkeys:

Analysis > Fixture Simulator

To enable/disable the port impedance conversion function, click on the **Port Z Conversion** field.

To enter the value of the simulated impedance of Port, click on the **Port Z0** field and enter the value using the on-screen keypad.

6.3.2 De-embedding

De-embedding is a function of the S-parameter transformation by removing of some circuit effect from the measurement results.

The circuit being removed should be defined in the data file containing S-parameters of this circuit. The circuit should be described as a 2-port in Touchstone file (extension .s2p), which contains the S-parameter table: S11, S21, S12, S22 for a number of frequencies.

The de-embedding function allows to mathematically exclude from the measurement results the effect of the fixture circuit existing between the calibration plane and the DUT in the real network. The fixture is used for the DUTs, which cannot be directly connected to the test ports.

The de-embedding function shifts the calibration plane closer to the DUT, so as if the calibration has been executed of the network with this circuit removed (See figure 6.10).

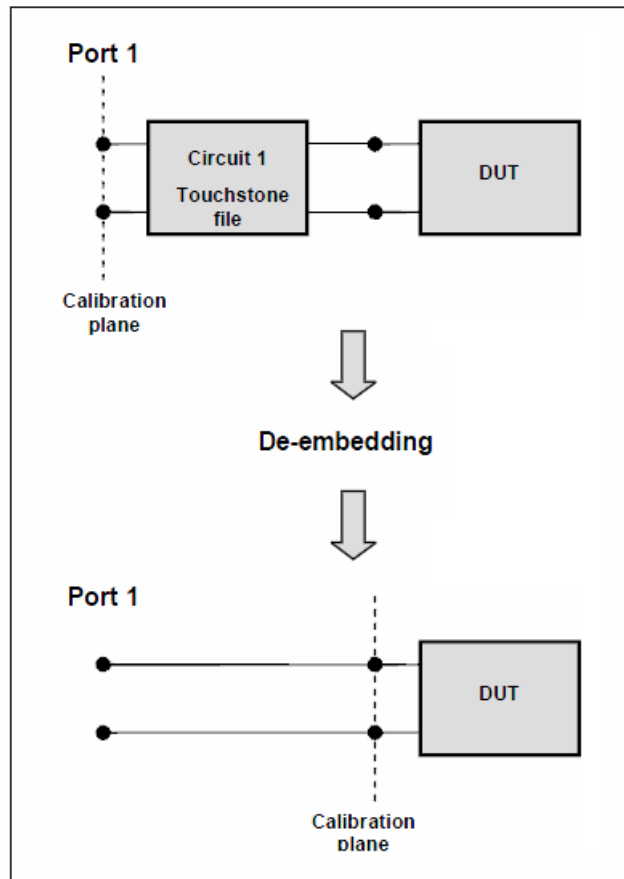
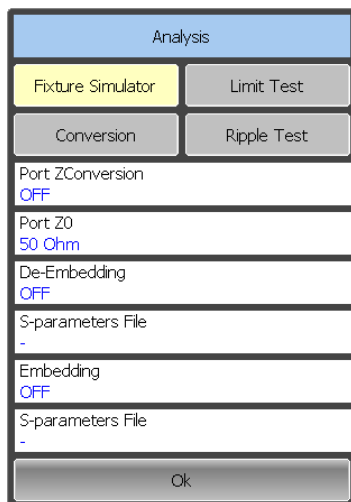

Figure 6.10 De-embedding



To enable/disable the de-embedding function for port 1, use the following softkeys:

Analysis > Fixture Simulator

And click on the **De-Embedding** field to toggle between the on/off status.

To enter the file name of the de-embedded circuit S – parameters of port 1, click on the **S - parameters File** field.

Note

If S-parameters file is not specified, the field of the function activation will be grayed out.

6.3.3 Embedding

Embedding is a function of the S-parameter transformation by integration of some virtual circuit into the real network (See figure 6.11). The embedding function is an inverted de-embedding function.

The circuit being integrated should be defined in the data file containing S-parameters of this circuit. The circuit should be described as a 2-port in Touchstone file (extension .s2p), which contains the S-parameter table: S11, S21, S12, S22 for a number of frequencies.

The embedding function allows to mathematically simulate the DUT parameters after adding of the fixture circuits.

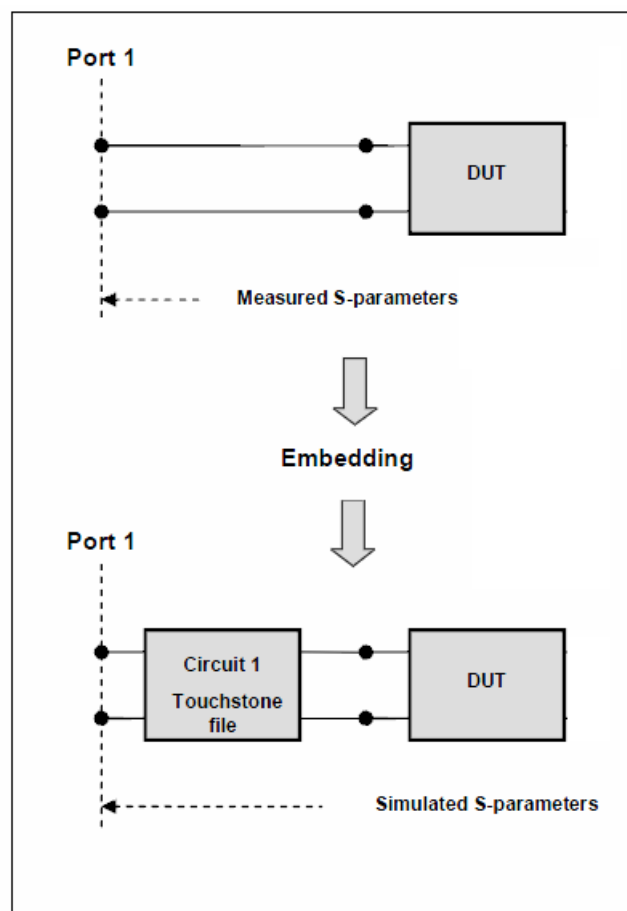
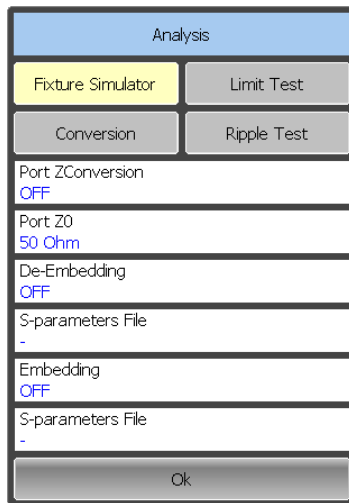

Figure 6.11 Embedding



To enable/disable the embedding function for port 1, use the following softkeys:

Analysis > Fixture Simulator

And click on the **Embedding** field to toggle between the on/off status.

To enter the file name of the embedded circuit S – parameters of port 1, click on the **S - parameters File** field.

Note If S-parameters file is not specified, the field of the function activation will be grayed out.

6.4 Time Domain Transformation

The Analyzer measures and displays parameters of the DUT in frequency domain. Time domain transformation is a function of mathematical modification of the measured parameters in order to obtain the time domain representation.

For time domain transformation Z-transformation and frequency domain window function are applied.

The time domain transformation can be activated for separate traces of a channel. The current frequency parameters S_{11} of the trace will be transformed into the time domain.

Note Traces in frequency and time domains can simultaneously belong to one channel. The stimulus axis label will be displayed for the active trace, in frequency or time units.

The transformation function allows for setting of the measurement range in time domain within Z-transformation ambiguity range. The ambiguity range is determined by the measurement step in the frequency domain:

$$\Delta T = \frac{1}{\Delta F}; \quad \Delta F = \frac{F_{\max} - F_{\min}}{N - 1}$$

The time domain function simulates the impulse bandpass response. It allows the user to obtain the response for circuits incapable of direct current passing. The frequency range is arbitrary in this mode.

The time domain transformation function applies Kaiser window for initial data processing in frequency domain. The window function allows to reduce the ringing (side lobes) in the time domain. The ringing is caused by the abrupt change of the data at the limits of the frequency domain. But while side lobes are reduced, the main pulse or front edge of the lowpass step becomes wider.

The Kaiser window is described by β parameter, which smoothly fine-tune the window shape from minimum (rectangular) to maximum. The user can fine-tune the window shape or select one of the three preprogrammed windows:

- Minimum (rectangular);
- Normal;
- Maximum.

Table 6.4 Preprogrammed window types

Window	Radio Pulse	
	Side Lobes Level	Pulse Width (50%)
Minimum	– 13 dB	$\frac{0.6 \cdot 2}{F_{max} - F_{min}}$
Normal	– 44 dB	$\frac{0.98 \cdot 2}{F_{max} - F_{min}}$
Maximum	– 75 dB	$\frac{1.39 \cdot 2}{F_{max} - F_{min}}$

6.4.1 Time Domain Transformation Activating

To enable/disable time domain transformation function select DTF SWR or DTF Return Loss trace format (as described in section 4.5.5)

Note Time domain transformation function is accessible only in linear frequency sweep mode.

6.4.2 Time Domain Transformation Span

To define the span of time domain representation, you can set start and stop values.



Stimulus	
Start Frequency	85 MHz
Stop Frequency	5.4 GHz
Time-Domain Start	-1.498962 m
Time-Domain Stop	1.498962 m
Points	201
Power	High
Sweep Type	Ln
Segment Table	Ok

To set the start and stop limits of the time domain range, use **Stimulus** softkey.

Click on the **Time-Domain Start** or **Time-Domain Stop** field and enter the value using the on-screen keypad.

6.4.3 Time Domain Transformation Window Shape Setting



DTF Settings	
DTF Unit	Metric, m
Cable	User Defined
Velocity	1
Cable Loss	0 dB/m
Cable Loss Correction	OFF
Kaiser Window	Normal
Ok	

Kaiser Window	
Minimum	
Normal	
Maximum	
Cancel	Ok

To set the window shape, use the **DTF Settings** softkey.

Click on the **Kaiser Window** field.

Then select the required shape from the **Kaiser Window** list and complete the setting by

Ok

6.5 Time Domain Gating

Time domain gating is a function, which mathematically removes the unwanted responses in time domain. The function performs time domain transformation and applies reverse transformation back to frequency domain to the user-defined span in

time domain. The function allows the user to remove spurious effects of the fixture devices from the frequency response, if the useful signal and spurious signal are separable in time domain.

Note	Use time domain function for viewing the layout of useful and spurious responses. Then enable time domain gating and set the gate span to remove as much of spurious response as possible. After that disable the time domain function and view the response without spurious effects in frequency domain.
------	--

The function involves two types of time domain gating:

- **bandpass** – removes the response outside the gate span,
- **notch** – removes the response inside the gate span.

The rectangular window shape in frequency domain leads to spurious sidelobes due to sharp signal changes at the limits of the window. The following gate shapes are offered to reduce the sidelobes:

- **maximum**;
- **wide**;
- **normal**;
- **minimum**.

The minimum window has the shape close to rectangular. The maximum window has more smoothed shape. From minimum to maximum window shape, the sidelobe level increases and the gate resolution reduces. The choice of the window shape is always a trade-off between the gate resolution and the level of spurious sidelobes. The parameters of different window shapes are represented in table 6.4.

Table 6.4 Time domain gating window shapes

Window Shape	Bandpass Sidelobe Level	Gate Resolution (Minimum Gate Span)
Minimum	- 48 dB	$\frac{2.8}{F_{\max} - F_{\min}}$
Normal	- 68 dB	$\frac{5.6}{F_{\max} - F_{\min}}$
Wide	- 57 dB	$\frac{8.8}{F_{\max} - F_{\min}}$
Maximum	- 70 dB	$\frac{25.4}{F_{\max} - F_{\min}}$

6.5.1 Time Domain Gate Activating

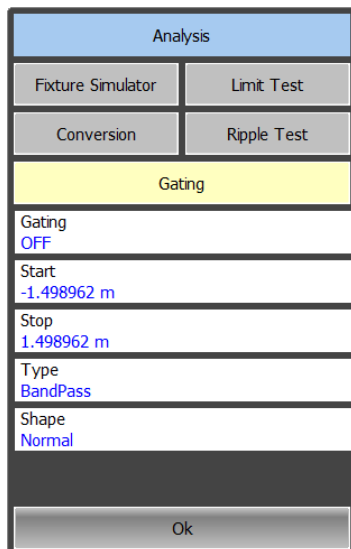

To enable/disable the time domain gating function: toggle the following softkey:

Analysis > Gating

Click on the **Gating** field to toggle between the on/off settings.

Note

Time domain gating function is accessible only in linear frequency sweep mode.

6.5.2 Time Domain Gate Span

To define the span of time domain gate, you can set its start and stop values.

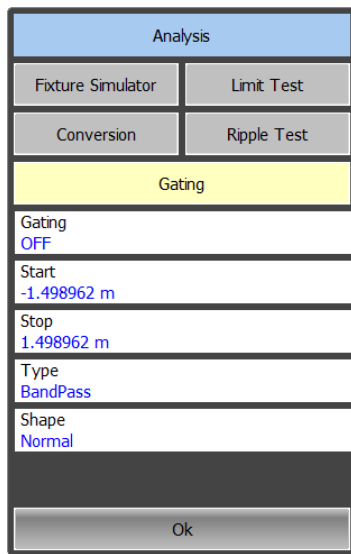

To set the start and stop of the time domain gate, use the following softkeys:

Analysis > Gating

Click on the **Start** or **Stop** field and enter the value using the on-screen keypad

6.5.3 Time Domain Gate Type

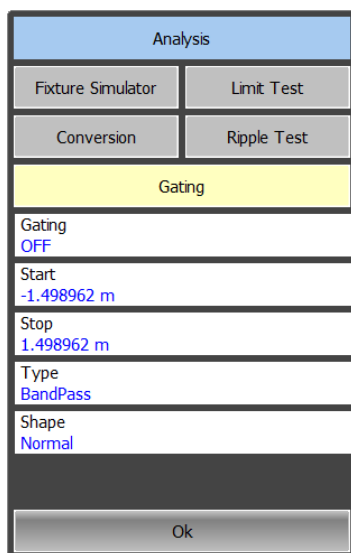

To select the type of the time domain window, use the following softkeys:

Analysis > Gating

Click on the **Type** field to toggle the type between **Bandpass** and **Notch**.

6.5.4 Time Domain Gate Shape Setting

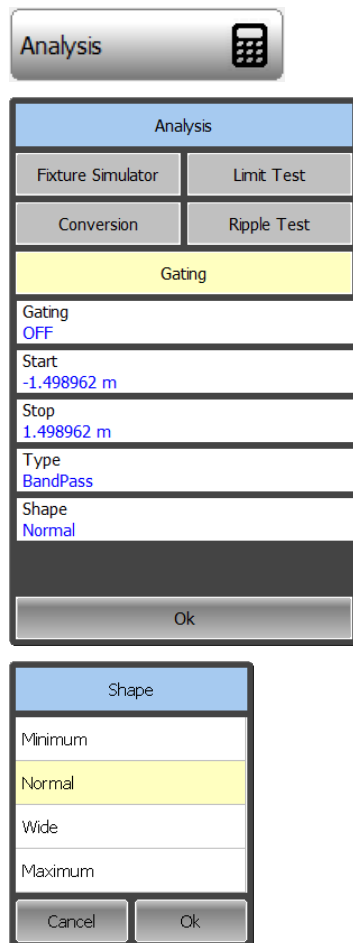

To set the time domain gate shape, use the following softkeys:

Analysis > Gating

Click on the **Shape** field to select the shape between

Minimum, Normal, Wide or Maximum

6.6 S-Parameter Conversion

S-parameter conversion function allows conversion of the measurement results (S_{11}) to the following parameters:

Equivalent impedance (Z_r) and equivalent admittance (Y_r) in reflection measurement:

$$Z_r = Z_0 \cdot \frac{1 + S_{11}}{1 - S_{11}}$$

$$Y_r = \frac{1}{Z_r}$$

Inverse S-parameter ($1/S$) for reflection measurements:

$$\frac{1}{S_{11}}$$

S-parameter complex conjugate.

S-parameter conversion function can be applied to an individual trace of a channel. Before enabling the function, first activate the trace.

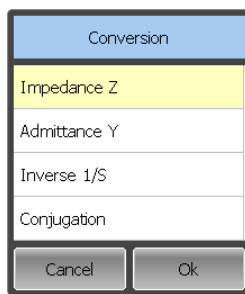
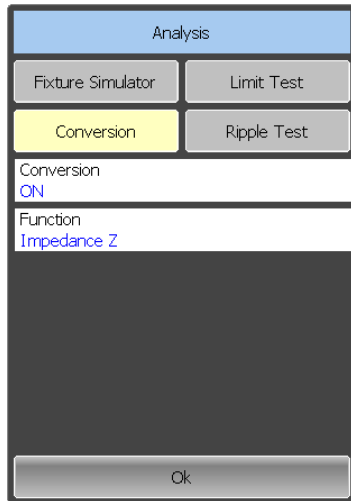

To enable/disable the conversion, use the following softkey:

Analysis

Then select the **Conversion** tab and click on the **Conversion** parameter value.

To select the conversion type, click on the **Function** field and select the required value from the list.

The trace format will be converted to linear – **Lin Magnitude**

Note

All conversion types are indicated in the trace status field, if enabled.

6.7 Limit Test

The limit test is a function of automatic pass/fail judgment for the trace of the measurement result. The judgment is based on the comparison of the trace to the limit line set by the user.

The limit line can consist of one or several segments (See figure 6.12). Each segment checks the measurement value for failing whether upper or lower limit. The limit line segment is defined by specifying the coordinates of the beginning (X0, Y0) and the end (X1, Y1) of the segment, and type of the limit. The MAX or MIN limit types check if the trace falls outside of the upper or lower limit respectively.

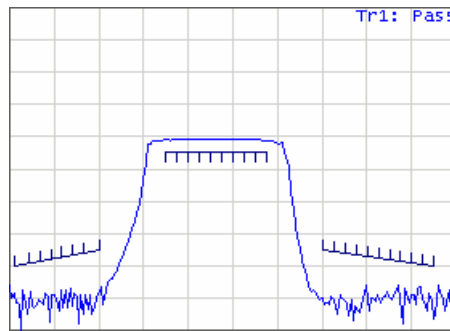

Figure 6.12 Limit line

The limit line is set by the user in the limit table. Each row in the table describes one segment of the line. Limit table editing is described below. The table can be saved into a *.lim file.

The display of the limit lines on the screen can be turned on/off independently of the status of the limit test function.

The result of the limit test is indicated in the center of the window.

If the measurement result failed Fail sign will be displayed in red, otherwise Pass sign will be displayed in green

6.7.1 Limit Line Editing

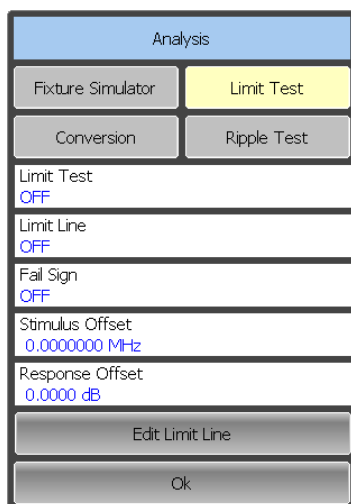

To access the limit line editing mode, use the following softkeys:

Analysis > Limit Test > Edit Limit Line

The Edit Limit Line dialog will appear in the the screen (See figure 6.13).

Edit Limit Line					
	Begin Stimulus	End Stimulus	Begin Response	End Response	Type
1	100.0 MHz	600.0 MHz	-3.0 dB	-3.0 dB	Max
2	800.0 MHz	1200.0 MHz	10.0 dB	10.0 dB	Min

Add Delete Clear Limit Table
 Save Limit Table Restore Limit Table Ok

Figure 6.13 Limit line table

To add a new row in the table, click **Add**. The new row will appear below the highlighted one.

To delete a row from the table, click **Delete**. The highlighted row will be deleted.

To clear the entire table, use **Clear Limit Table** softkey.

To save the table into *.lim file, use **Save Limit Table** softkey.

To open the table from a *.lim file, use **Restore Limit Table** softkey.

Navigating in the table to enter the values of the following parameters of a limit test segment:

Begin Stimulus Stimulus value in the beginning point of the segment

End Stimulus Stimulus value in the ending point of the segment

Begin Response Response value in the beginning point of the segment

End Response Response value in the ending point of the segment.

Type Select the segment type among the following:

- **MAX** – upper limit
- **MIN** – lower limit
- **OFF** — segment not used for the limit test

6.7.2 Limit Test Enabling/Disabling

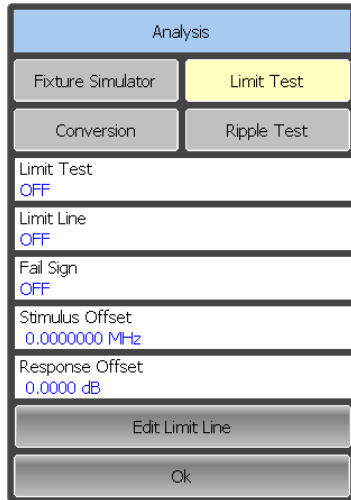

To enable/disable limit test function, use the following softkeys:

Analysis > Limit Test

Click on the **Limit Test** field to toggle between the on/off settings.

6.7.3 Limit Test Display Management

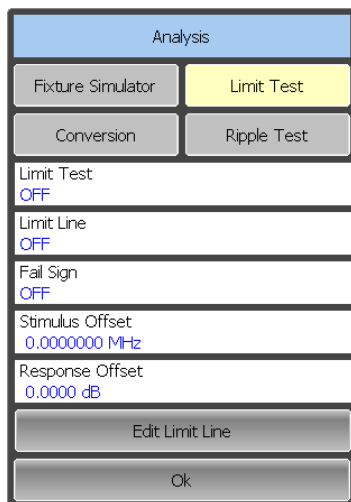

To enable/disable display of a **Limit Line**, use the following softkeys:

Analysis > Limit Test

To enable/disable display of **Fail sign** in the center of the graph, click on the **Limit Line** field to toggle between the on/off settings.

6.7.4 Limit Line Offset

Limit line offset function allows the user to shift the segments of the limit line by the specified value along X and Y axes simultaneously

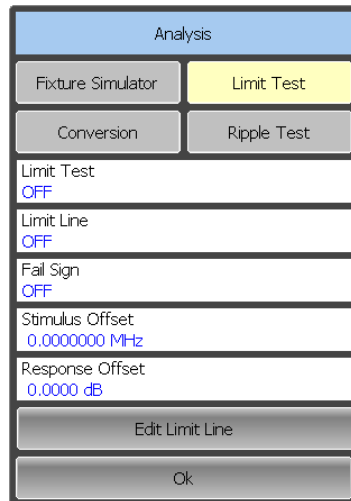

To define the limit line offset along X-axis, use the following softkeys:

Analysis > Limit Test

Click on the **Stimulus Offset** field and enter the value using the on-screen keypad

To define the limit line offset along Y-axis, click on the **Response Offset** field and enter the value using the on-screen keypad

6.8 Ripple Limit Test

Ripple limit test is an automatic pass/fail check of the measured trace data. The trace is checked against the maximum ripple value (**ripple limit**) defined by the user. The ripple value is the difference between the maximum and minimum response of the trace in the trace frequency band.

The ripple limit can include one or more segments (See figure 6.14). Each segment provides the ripple limit for the specific frequency band. A segment is set by the frequency band and the ripple limit value.

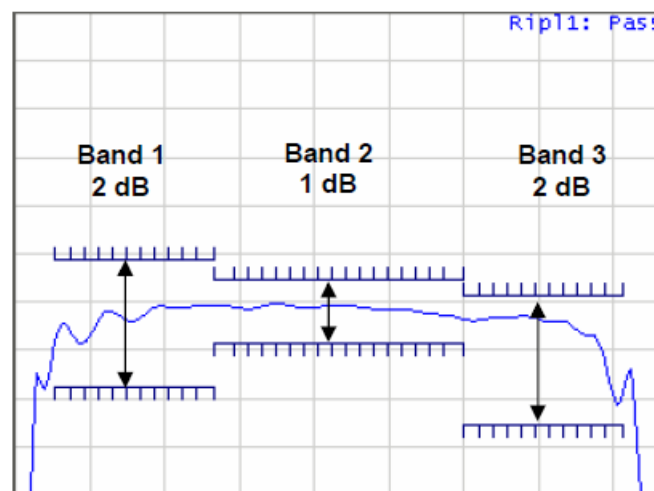

Figure 6.14 Ripple limits

The ripple limit settings are performed in the ripple limit table. Each row of the table describes the frequency band the ripple limit value. The ripple limit table editing is described below. The table can be saved into a *.lim file.

The display of the limit lines on the screen can be turned on/off by the user.

If the measurement result failed, **Fail** sign will be displayed in red in the center of the window.

6.8.1 Ripple Limit Editing



To access the ripple limit editing mode, use the following softkeys:

Analysis > Ripple Test > Edit Ripple Limit

The **Edit Ripple Limit** dialog will appear in the screen (See figure 6.15).

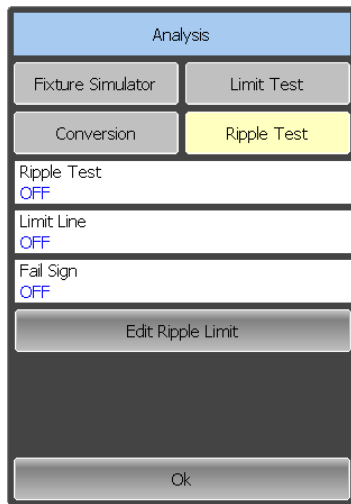

Edit Ripple Limit				
	Begin Stimulus	End Stimulus	Ripple Limit	Type
1	100.0 MHz	800.0 MHz	0.2 dB	ON
2	800.0 MHz	2400.0 MHz	0.8 dB	ON
<div style="display: flex; justify-content: space-around;"> Add Delete Clear Ripple Table </div> <div style="display: flex; justify-content: space-around;"> Save Ripple Table Restore Ripple Table Ok </div>				

Figure 6.15 Ripple limit table

To add a new row in the table, click **Add**. The new row will appear below the highlighted one.

To delete a row from the table, click **Delete**. The highlighted row will be deleted.

To clear the entire table, use **Clear Ripple Limit** Table softkey.

To save the table into *.rlm file, use **Save Ripple Limit** Table softkey.

To open the table from a *.rlm file, use **Recall Ripple Limit** Table softkey

Navigating in the table to enter the values of the following parameters of a ripple limit test segment:

Begin Stimulus	Stimulus value in the beginning point of the segment
End Stimulus	Stimulus value in the ending point of the segment
Ripple Limit	Ripple limit value
Type	Select the segment type among the following: <ul style="list-style-type: none"> • ON – band used for the ripple limit test • OFF — band not used for the limit test

6.8.2 Ripple Limit Enabling/Disabling



To enable/disable ripple limit test function, use the following softkeys:

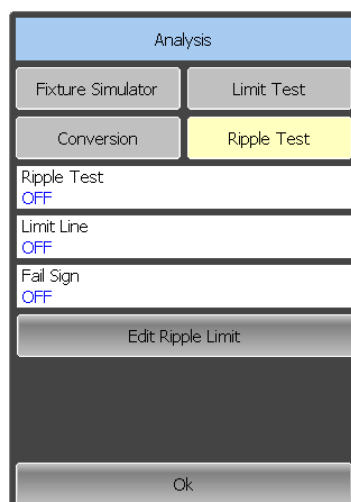

Analysis > Ripple Test

Click on the **Ripple Test** field to toggle between the on/off settings.

6.8.3 Ripple Limit Test Display Management

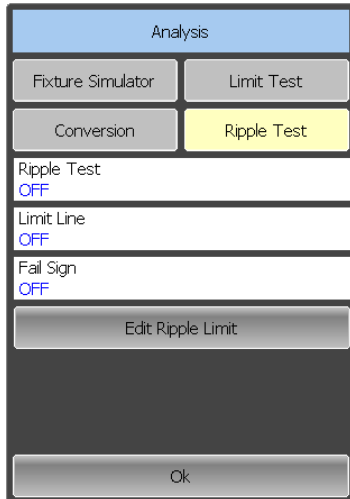

To enable/disable display of the *ripple limit line*, use the following softkeys:

Analysis > Ripple Test

Click on the **Limit Line** field to toggle between the on/off settings.

To enable/disable display of the **Fail sign** in the center of the graph, use the following softkeys:

Analysis > Ripple Limit

Click on the **Fail Sign** field to toggle between the on/off settings.

7 CABLE LOSS MEASUREMENT

While all cables have inherent loss, weather and time will deteriorate cables and cause even more energy to be absorbed by the cable. This makes less power available to be transmitted.

A deteriorated cable is not usually apparent in a Distance to Fault measurement, where more obvious and dramatic problems are identified. A Cable Loss measurement is necessary to measure the accumulated losses throughout the length of the cable.

In high-loss conditions, a Cable Loss measurement becomes “noisy” as the test signal becomes indistinguishable in the device noise floor. This can occur when measuring a very long cable and using relatively high measurement frequencies. To help with this condition, use High Power, and Averaging.

7.1 Cable Loss Measurement Algorithm

In order to measure Cable Loss, perform the following steps:

- Set the device to initial state of the **System -> Preset**;
- Select for the current trace type of measurement **Cable Loss**;
- Set the Start and Stop frequency of measurements;
- Perform a full 1-port calibration for measuring port;
- Connect the cable to be tested;
- Connect a LOAD at the end of the cable to be tested. This limits the reflections to faults that are located in the cable under test. These reflections are visible on the screen as “ripple” or low-level standing waves and obscure the actual loss of the cable;
- Save the trace data in memory using the buttons **Trace -> Memory Trace**;
- Remove the LOAD and leave the end of the cable to be tested open;
- Press **Trace-> Data Math -> Data – Mem**. The ripple in the measurement is removed. These minor imperfections in the cable should not be considered in the Cable Loss measurement;
- Use Averaging to remove random noise from high-loss measurements. To turn on the averaging press the buttons **Average -> Averaging**.

The displayed trace shows the Cable Loss values in one direction through the cable. A Return Loss measurement would show the loss for both down the cable and back. Therefore, a Cable Loss measurement is the same as a Return Loss measurement divided by 2.

8 REFLECTOMETER DATA OUTPUT

8.1 Reflectometer State

The Reflectometer state, calibration, actual trace and memory traces can be saved to the Reflectometer state file and later uploaded back into the Reflectometer program.

The following four types of saving are available:

State	The Reflectometer settings
State & Cal	The Reflectometer settings and the table of calibration coefficients
State & Trace	The Reflectometer settings and data traces
All	The Reflectometer settings, table of calibration coefficients, and data traces

The Reflectometer settings that become saved into the state file are the parameters, which can be set in the following submenus of the softkey menu:

- All the parameters in Stimulus submenu;
- All the parameters in Scale submenu;
- All the parameters in Channel submenu;
- All the parameters in Trace submenu;
- All the parameters in System submenu;
- All the parameters in Average submenu;
- All the parameters of Markers submenu;
- All the parameters of Analysis submenu;

A special **Autosave.cfg** file is used to automatically recall the Reflectometer state after start. To be able to use this function, you have to enable the automatic state saving mode.

8.1.1 Reflectometer State Saving



Files	
Autosave ON	
Save Type State and Cal	
Save State	Recall State
Save Calibration	Recall Calibration
Touchstone Format Real-Imaginary	
Type S1P	Recall To Active Memory
Save Touchstone	Recall Touchstone
Save Trace Data	Ok

Save Type	
State	
State and Cal	
State and Trace	
All	
Cancel	Ok

Save State		Drive
Path C:\Qbzor\Caban_UTF16\State		
..		
Autosave.cfg		
Test1.cfg		
WIFI.cfg		
File noname.cfg		
Cancel	Ok	

To save the Reflectometer state, use the following softkeys:

Files > Save State

To set type of saving click on **Save Type** field. Select type in **Save Type** dialog and click **Ok**

Select a path and enter the state file name in the pop-up dialog.

Navigation in directory tree is available in **Save State** dialog.

To open a directory and activate it, double click on the directory name.

To go up in the directory hierarchy, double click on the “..” field.

To select the disk, click

Drive

To change the name of the saved state file using the on-screen keypad, click on the **File** field.

To save the state file in the **Save State** dialog click

Ok

8.1.2 Reflectometer State Recalling

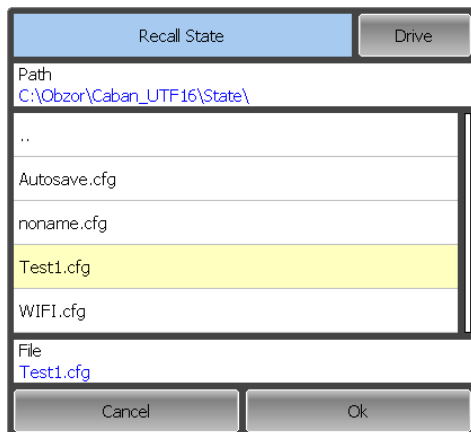
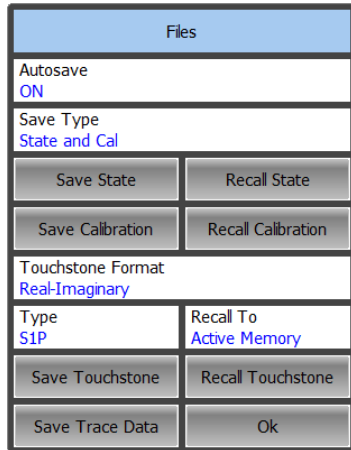

To recall the state from a file of Reflectometer state, use the following softkeys:

Files > Recall State

Select the state file name in the pop-up dialog.

Navigation in directory tree is available in **Recall State** dialog.

To open a directory and activate it, double click on the directory name.

To go up in the directory hierarchy, double click on the "... " field.

To select the disk, click

Drive

To recall the state from file in the **Recall State** dialog click **Ok**

8.1.3 Autosave and Autorecall State of Reflectometer



Files	
Autosave ON	
Save Type State and Cal	
Save State	Recall State
Save Calibration	Recall Calibration
Touchstone Format Real-Imaginary	
Type S1P	Recall To Active Memory
Save Touchstone	Recall Touchstone
Save Trace Data	Ok

To save a state which will be automatically recalled after start, use the softkey:

Files

Click in the **Autosave** parameter value field. The parameter value will change to **ON**.

When leaving the program, the state will be saved. The next time the program state will be restored.

8.2 Channel State

A channel state can be saved into the RAM. The channel state saving procedure is similar to saving of the Reflectometer state saving, and the same saving types (described in section 8.1) are applied to the channel state saving.

Unlike the Reflectometer state, the channel state is saved into the RAM (not to the hard disk) and is cleared when the program is closed.

For channel state storage, there are four memory registers A, B, C, D.

The channel state saving allows the user to easily copy the settings of one channel to another one.

8.2.1 Channel State Saving



To save the Channel state, use the following softkeys:

Channels > Save Channel

To save the state click **State A | State B | State C | State D** softkey in the **Save Channel** dialog.

To select a save option click on **Save Type** field.

To clear all saved states click on **Clear States** softkey.

8.2.2 Channel State Recalling

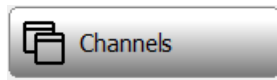

Channels	
Active Channel 1	
Maximize Channel OFF	
x1 <input type="checkbox"/>	x2 <input type="checkbox"/>
Save Type State and Cal	
Save Channel	Recall Channel
Ok	

Recall Channel	
State A	<input checked="" type="checkbox"/>
State B	<input type="checkbox"/>
State C	<input type="checkbox"/>
State D	<input type="checkbox"/>
Cancel	

To recall the active channel state, use the following softkeys:

Channels > Recall Channel

Click the required softkey of the available **State A** | **State B** | **State C** | **State D**.

If the state with some number was not saved the corresponding softkey will be grayed out.

8.3 Trace Data CSV File

The Reflectometer allows to save an individual trace data as a CSV file (comma separated values). The *.CSV file contains digital data separated by commas. The active trace stimulus and response values in current format are saved to *.CSV file.

Only one (active) trace data are saved to the file.

The trace data are saved to *.CSV in the following format:

F[0],	Data1,	Data2
F[1],	Data1,	Data2
	. . .	
F[N],	Data1,	Data2

F[n] – frequency at measurement point n;

Data1 – trace response in rectangular format, real part in Smith chart and polar format;

Data2 – zero in rectangular format, imaginary part in Smith chart and polar format.

8.3.1 CSV File Saving

To save the trace data, first activate the trace.

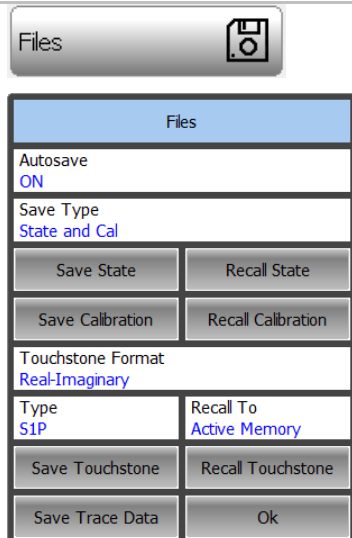

To save the trace data, use the following softkeys:

Files > Save Trace Data

Select a path and enter the file name in the pop-up dialog.

Navigation in directory tree is available in **Save Data** dialog.

To open a directory and activate it, double click on the directory name.

To go up in the directory hierarchy, double click on the “...” field.

To select the disk, click

Drive

To change the name of the saved file using the on-screen keypad, double click on the **File** field.

To save the file, in the **Save Data** dialog click

Ok

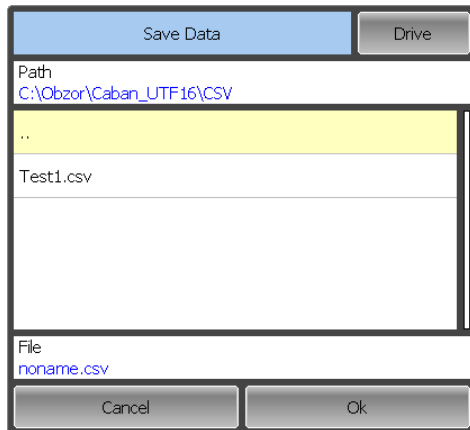

8.4 Trace Data Touchstone File

The Reflectometer allows the user to save S-parameters to a Touchstone file. The Touchstone file contains the frequency values and S-parameters. The files of this format are typical for most of circuit simulator programs.

The *.s1p files are used for saving the parameters of a 1-port device.

The *.s2p files are used for saving the parameters of a 2-port device.

Only one active trace data are saved to the file.

The Touchstone file contains comments, header, and trace data lines. Comments start with «!» symbol. Header starts with «#» symbol.

The Touchstone file contains comments, header, and trace data lines. Comments start with symbol. Header starts with «#» symbol.

The *.s1p Touchstone file for 1-port measurements:

```
! Comments
# Hz S FMT R ZO
F[1]  {S11}'  {S11}"
F[2]  {S11}'  {S11}"
. . .
F[N]  {S11}'  {S11}"
```

The *.s2p Touchstone file for 2-port measurements:

```
! Comments
# Hz S FMT R ZO
F[1]  {S11}'  {S11}"  {S21}'  {S21}"  {S12}'  {S12}"  {S22}'  {S22}"
F[2]  {S11}'  {S11}"  {S21}'  {S21}"  {S12}'  {S12}"  {S22}'  {S22}"
. . .
F[N]  {S11}'  {S11}"  {S21}'  {S21}"  {S12}'  {S12}"  {S22}'  {S22}"
```

where:

Hz – frequency measurement units (kHz, MHz, GHz)

FMT – data format:

RI – real and imaginary parts,

MA – linear magnitude and phase in degrees,

DB – logarithmic magnitude in dB and phase in degrees.

Z0 – reference impedance value

F[n] – frequency at measurement point n

{...}' – {real part (RI) | linear magnitude (MA) | logarithmic magnitude (DB)}

{...}" – {imaginary part (RI) | phase in degrees (MA) | phase in degrees (DB)}

The Touchstone file saving function is applied to individual channels. To use this function, first activate the channel.

8.4.1 Touchstone File Saving

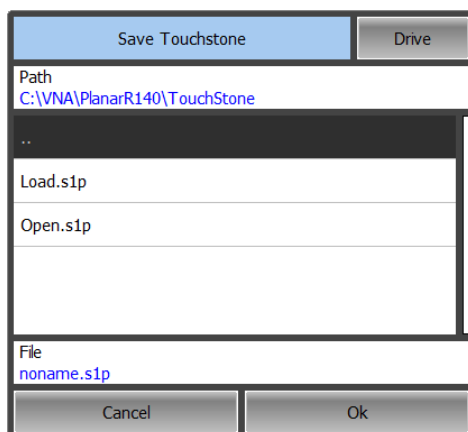
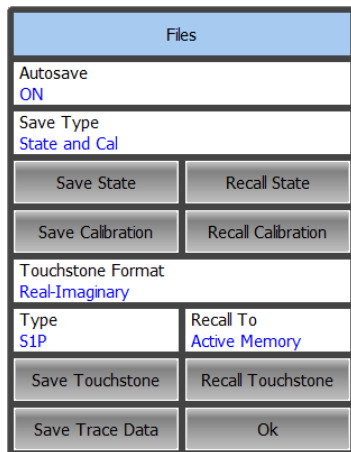

To save the Touchstone format data, use the following softkeys:

Files > Save Touchstone

Select a path and enter the file name in the pop-up dialog.

Navigation in directory tree is available in **Save Touchstone** dialog.

To open directory and activate it, double click on the directory name.

To go up in the directory hierarchy, double click on the “...” field.

To select the disk, click

Drive

To change the name of the saved file using the on-screen keypad, click on the **File** field.

To save the file, in the **Save Touchstone** dialog click

Ok

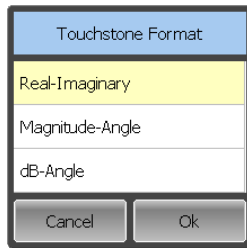

To select the saved Touchstone file format click on the **Touchstone Format** field and select the required format from the **Touchstone Format** list.

Complete by

Ok

To select the type (S1P or S2P) of Touchstone file click on the **Type** field.

Real data is used for S11 and zero values for S12, S21, S22.

8.4.2 Touchstone File Recalling

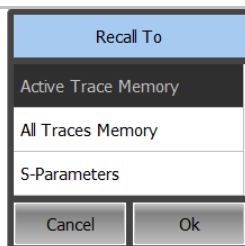
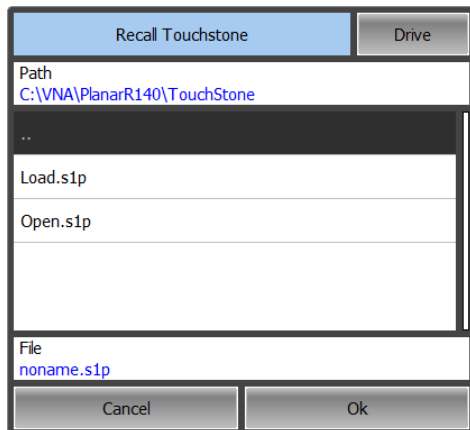
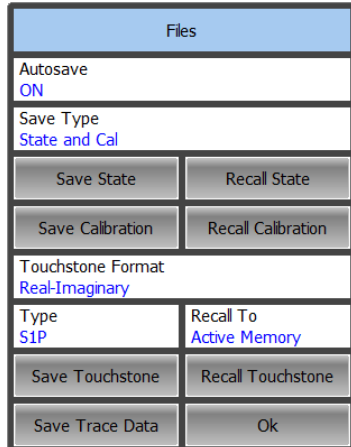

To recall the data trace, use the following softkeys:

Files > Recall Touchstone

Select a path and enter the file name in the pop-up dialog.

Navigation in directory tree is available in **Recall Touchstone** dialog.

To open directory and activate it, double click on the directory name.

To go up in the directory hierarchy, double click on the "... " field.

To select the disk click

Drive

To recall the file in the **Recall Touchstone** dialog click

Ok

You can load data into the active trace memory, all trace memory or measured by the S parameter.

To select download option click on the **Recall To** field.

Complete by **Ok**.

Note

After downloading the file touchstone in the S-parameters frequency scanning will stop

8.5 Graph Printing

This section describes the print/save procedures for the graph data.

You can print out the graphs using three different applications:

- MS Word;
- Image Viewer for MS Windows;
- Save screen shot in *.png format using the program menu

Note

MS Word application must be installed in MS Windows system.

You can select the print color before the image is transferred to the printing application:

- Color (no changes);
- Gray Scale;
- Black & White.

You can invert the image before it is transferred to the printing application.

You can add current date and time before the image is transferred to the printing application.

8.5.1 Graph Printing Procedure

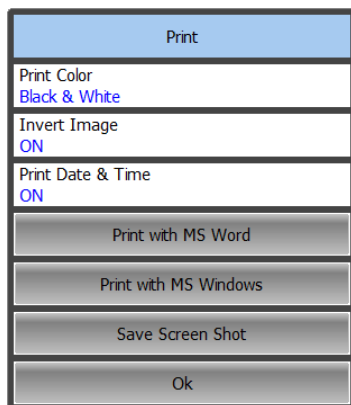

To print channels graph area use the following softkeys:

Print > Print with MS Word | Print with MS Window

To select the print color click on the **Print Color** field.

If necessary, invert the image by **Invert Image** field.

If necessary, select printing of date and time by **Print Date& Time** field.

Close **Print** dialog by

Ok

8.5.2 Quick saving program screen shot

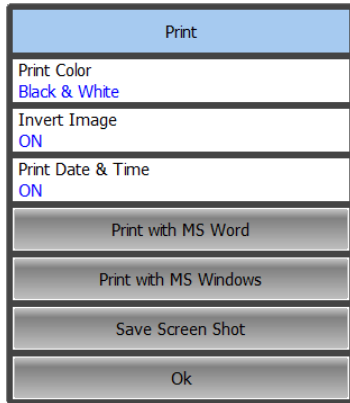

To save screen shot of the channels graph data use the **Print** softkey.

Click **Screen Shot** softkey in the **Print** dialog.

The files will be saved to the **Image** folder located in the main program folder. The saved files will be automatically assigned the following name:

scrXXXXX.png

where **XXXXX** is automatically incremented ordinal number.

9 SYSTEM SETTINGS

9.1 Reflectometer Presetting

Reflectometer presetting feature allows the user to restore the default settings of the instrument.

The default settings of your Reflectometer are specified in Appendix 1.

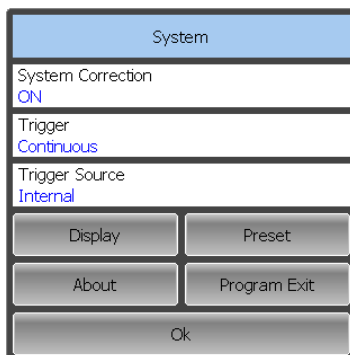

To preset the Reflectometer, use the following softkeys:

System > Preset

9.2 Program Exit

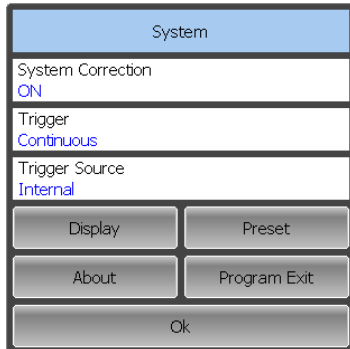
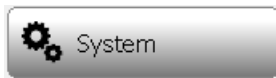

To exit the program, use the following softkeys in the right menu bar:

System > Program Exit

9.3 Reflectometer System Data

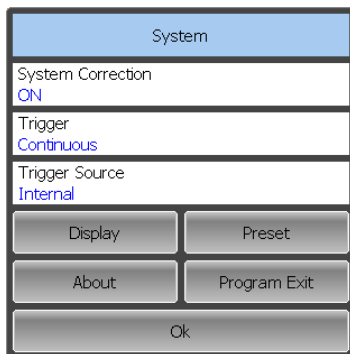
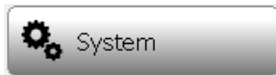

To get the information about software version, hardware revision and serial number of the Reflectometer, use the following softkeys in the right menu bar:

System > About

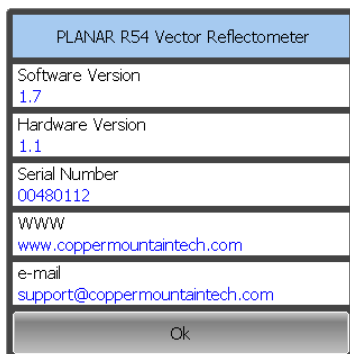

9.4 System Correction Setting

The Reflectometer is supplied from the manufacturer calibrated with the calibration coefficients stored in its non-volatile memory. The factory calibration is used by default for initial correction of the measured S-parameters. Such calibration is referred to as system calibration, and the error correction is referred to as system correction.

The system correction ensures initial values of the measured S-parameters before the Reflectometer is calibrated by the user. The system calibration is performed at the plane of the port physical connectors and leaves out of account the cables and other fixture used to connect the DUT. The measurement accuracy of the Reflectometer without its calibration with the user setup is not rated.

Normally, the disabling of the system correction is **not required** for a calibration and further measurements.

The system correction can be disabled only in case the user provided a proper calibration for the Reflectometer. The measurement accuracy is determined by user calibration and does not depend on the system correction status. The only rule that should be observed is to disable/enable the system correction before the user calibration, so that the calibration and further measurement could be performed under the same conditions.

If the system correction is disabled by the user, this is indicated in the instrument status bar:

System Correction Off

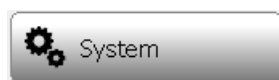

To disable/enable the system correction, use the **System** softkey

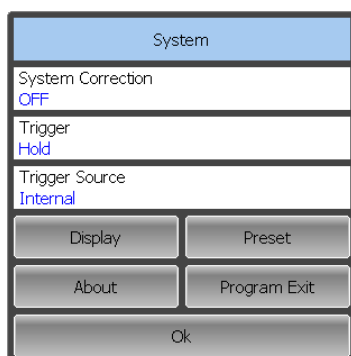

Click on the **System Correction** field to toggle between the on/off settings.

9.5 User Interface Setting

The Reflectometer enables you to make the following user interface settings:

- Toggle between full screen and window display
- Width of traces
- Font size in channel window
- Inverting colors in graph area
- Show/hide the channel title bar

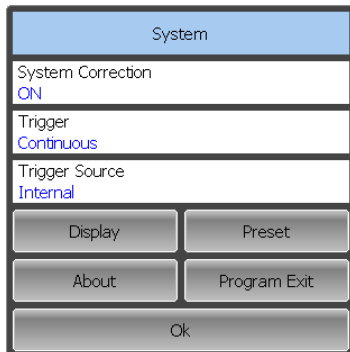
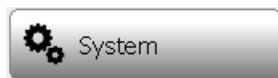

To toggle between full screen and window display, use the following softkeys:

System > Display

Click on **Full Screen** field to change the parameter value.

To change the width of a trace click on **Line Width** field and enter the required value using the on-screen keypad.

The width can be set from 1 to 4.

The changes made to the width of the lines will affect all the channels.

To change the font size in the channel window click on **Font Size** field and enter the required value using the on-screen keypad.

The size can be set from 8 to 24.

To change the color of the background of the graph click on **Inverse Color** field to toggle between the on/off settings.

To show/hide the channel title bar click on **Caption** field in the pop-up dialog to toggle between the ON/OFF settings.

To restore the default factory settings, use the softkeys:

Preset

10 SPECIFICS OF WORKING WITH TWO DEVICES PLANAR R54

Additional software for devices Planar R54 allows to use simultaneously two devices. This expands the list of parameters to be measured. You can measure $|S_{21}|$ and $|S_{12}|$ of the DUT using two Reflectometer.

The signal source can be only one device (active). The second device (passive) works as signal receiver. Active device has a green indicator READY/STANDBY, which is located on the top cover. The passive device has at the same time light the red and green LEDs.

Active instrument is assigned according to the measured S-parameters. When measuring the parameters S_{11} and S_{21} active will be the first device, the measurement of S_{12} and S_{22} - the second. If the channel window has a list of the S-parameters, the program will make a few launches of the scanning.

10.1 Installation of additional software

For simultaneous work with two devices Planar R54 you need a program PlanarR54x2.exe. The installation file is called Setup_PlanarR54x2_vX.X.exe. XX - it is a version of the software. Installation procedure is similar to that described in paragraph 2.2.

10.2 Connecting devices to a USB port

Important! Both devices Planar R54 must be connected to the pair USB interfaces, which are served by a single controller. Usually, these two USB ports of a personal computer are located near.

If two devices connected to different USB controllers of the computer, the work these devices will not be synchronous.

If necessary, you can use an external USB HUB with its own power supply.

The port numbers are assigned to devices in the order of their connection to a personal computer. If before the start of the program devices were plugged into the USB ports of the computer, the numbering of ports will go according to internal numbering of USB interfaces.

10.3 Frequency tuning of the internal generators

Internal reference generators of devices have the finite accuracy of frequency. When working with two devices you need to set the output frequency of one of the devices to the other. This eliminates the error in the measurement of the transmission coefficients, which arises from the fact that the frequency of a single device does not fall in the bandwidth of the filter another device.

By default, when you connect the two devices starts to work function of automatic frequency with a period of 30 seconds. The parameters of the automatic adjustment and its periodicity can be specified by user.

Immediately after you connect the two devices in the status bar of the program appears alarm indication:

Ref. Offset Failure!

When performing the frequency adjustment ports of the devices should be connected between themselves. It is necessary to ensure the weakening of the signal between the ports is not more than 50 dB.

The program provides self-tuning on a maximum of the signal in the frequency range, which is used in the active channel.

After successful completion of the adjustment alarm indication disappears.

Before using the instruments should be warmed up, to minimize the temperature drift of reference generators.

10.3.1 Manual frequency tuning



Device List		
No	Serial No	Port
1	00480112	1
2	00160112	2
Reference Offset Value 2.468726 Hz		
Auto Adjust Period OFF		
Adjust Immediate		
Ok		

To perform manual frequency adjustment press the soft keys:

Devices > Adjust Immediate

After the adjustment in the field **Reference Offset Value** will be shown a correction of the reference oscillator frequency of the second device.

10.3.2 Automatic frequency tuning

In a mode of the automatic adjustment of the frequency of the program performs the adjustment after a specified time interval. The real interval of adjustment can be more than specified.

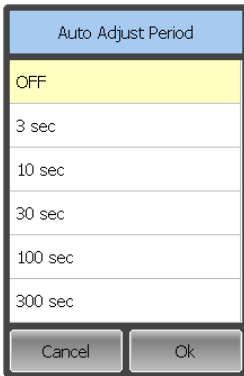

To perform automatic frequency adjustments press the softkey **Devices**.

Click the left mouse button on the field

Auto Adjust Period.

In dialogue form **Auto Adjust Period** select the time interval and press

OK.

10.4 The features of calibration of instruments

The calibration procedure described in paragraph 5, an expanded selection of ports, and the ability to calibrate the scalar coefficient of transmission.

Before calibration of **THRU** will be executed adjustment of frequency generators. Adjusts the frequency of the second device.

10.4.1 Port selection



To select the direction of the calibration, use the following softkey:

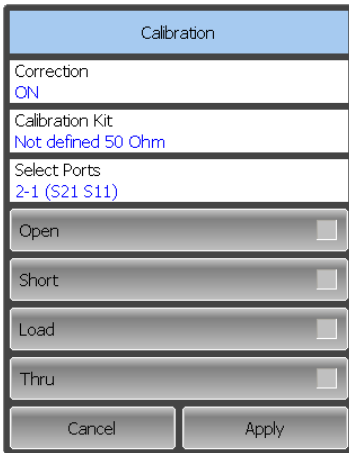

Calibration

Click on the **Select Ports** field to select required ports from the list.

Complete the setting by

Ok.

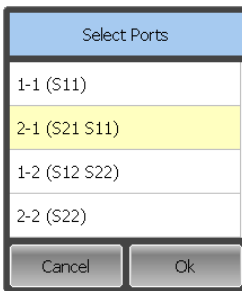

10.4.2 Scalar Transmission Normalization

Transmission normalization is the simplest calibration method used for transmission coefficient measurements (S21 or S12). One THRU standard is measured in the process of this calibration.

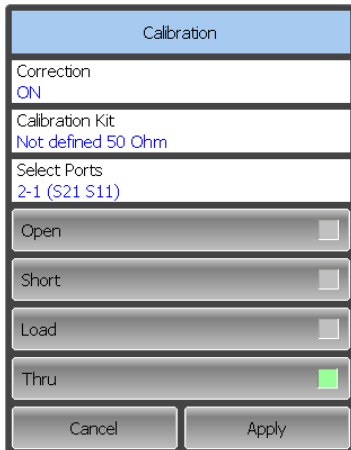

To execute transmission normalization use **Calibration** softkey.

Select the direction of the calibration using **Select Ports** field.

Connect a **THRU** standard between the test ports. If the port connectors allow through connection connect them directly (zero electrical length thru). Perform measurement using **Thru** softkey.

To complete the calibration procedure, click

Apply.

This will activate the process of calibration coefficient table calculation and saving it into the memory. The error correction function will also be automatically enabled.

To clear the measurement results of the standard, click

Cancel.

Note You can check the calibration status in trace status field (See section 4.2.2).

10.4.3 Expanded Transmission Normalization

Expanded Transmission Normalization is used for measurements of the DUT parameters in one direction, e.g. S11 and S21. This method involves connection of the three calibration standards to the source port, and connection of a THRU standard between the calibrated source port and the other receiver port.

Before starting calibration perform the following settings: select active channel, set the parameters of the channel (frequency range, IF bandwidth, etc), and select the calibration kit.

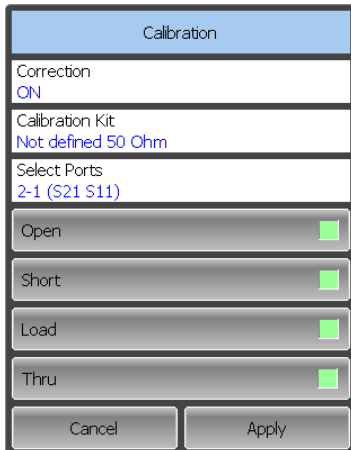

To execute transmission normalization use **Calibration** softkey.

Select the direction of the calibration using **Select Ports** field.

Connect a **THRU** standard between the test ports. If the port connectors allow through connection connect them directly (zero electrical length thru). Perform measurement using **Thru** softkey.

Connect **SHORT**, **OPEN** and **LOAD** standards to the source port in any consequence.

Perform measurements clicking the softkey corresponding to the connected standard

To complete the calibration procedure, click **Apply**.

This will activate the process of calibration coefficient table calculation and saving it into the memory. The error correction function will also be automatically enabled.

To clear the measurement results of the standard, click

Cancel.

10.5 Selection of the measured S-parameters

A measured parameter (S11, S21, S12, S22) is set for each trace. Before you select the measured parameter, first activate the trace.

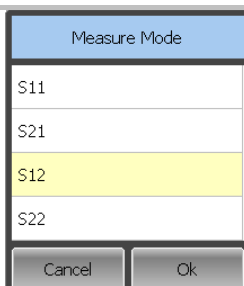

To assign the measured parameters (S11, S21, S12 or S22) to a trace, make a mouse click on the S-parameter name in the trace status line and select the required parameter in the dialog **Measure Mode**.

Complete the setting by

Ok.

11 MAINTENANCE AND STORAGE

11.1 Maintenance Procedures

This section describes the guidelines and procedures of maintenance, which will ensure fault-free operation of your Reflectometer.

The maintenance of the Reflectometer consists in cleaning of the instrument, factory calibrations, and regular performance tests.

11.1.1 Instrument Cleaning

This section provides the cleaning instructions required for maintaining the proper operation of your Reflectometer.

To remove contamination from parts other than test ports and any connectors of the Reflectometer, wipe them gently with a soft cloth that is dry or wetted with a small amount of water and wrung tightly.

It is essential to keep the test ports always clean as any dust or stains on them can significantly affect the measurement capabilities of the instrument. To clean the test ports (as well as other connectors of the Reflectometer), use the following procedure:

section

- clean the connectors using a lint-free cleaning cloth wetted with a small amount of ethanol and isopropyl alcohol (when cleaning a female connector, avoid snagging the cloth on the center conductor contact fingers by using short strokes).

Always completely dry a connector before using it.

Never use water or abrasives for cleaning any connectors of the Reflectometer.

Do not allow contact of alcohol to the surface of the insulators of the connectors.

When connecting male-female coaxial connectors always use a calibrated wrench.

11.1.2 Factory Calibration

Factory calibration is a regular calibration performed by the manufacturer or an authorized service center. We recommend you to send your Reflectometer for factory calibration every three years.

Factory calibration is a full one-port Reflectometer calibration. It can be performed in two following modes: with high output power and with low output power. The

calibration coefficients employed during the Reflectometer operation correspond to the selected mode of the output power.

The factory calibration of the Reflectometer allows performing measurement without additional calibration and reduces the measurement error for reflection normalization.

11.2 Storage Instructions

Before first use store your Reflectometer in the factory package at environment temperature from 0 to +40 °C and relative humidity up to 80% (at 25 °C).

After you have removed the factory package store the Reflectometer at environment temperature from +10 to +35 °C and relative humidity up to 80% (at 25 °C).

Ensure to keep the storage facilities free from dust, fumes of acids and alkalies, aggressive gases, and other chemicals, which can cause corrosion.

12 WARRANTY INFORMATION

1. The manufacturer warrants the Vector Reflectometer to conform to the specifications of this Manual when used in accordance with the regulations of operation detailed in this Manual.
2. The manufacturer will repair or replace without charge, at its option, any Reflectometer found defective in manufacture within the warranty period, which is twelve (12) months from the date of purchase. Should the user fail to submit the warranty card appropriately certified by the seller with its stamp and date of purchase the warranty period will be determined by the date of manufacture.
3. The warranty is considered void if:
 - a) the defect or damage is caused by improper storage, misuse, neglect, inadequate maintenance, or accident;
 - b) the product is tampered with, modified or repaired by an unauthorized party;
 - c) the product's seals are tampered with;
 - d) the product has mechanical damage.
4. The batteries are not included or covered by this warranty.
5. Transport risks and costs to and from the manufacturer or the authorized service centers are sustained by the buyer.
6. The manufacturer is not liable for direct or indirect damage of any kind to people or goods caused by the use of the product and/or suspension of use due to eventual repairs.
7. When returning the faulty product please include the accurate details of this product and clear description of the fault. The manufacturer reserves the right to check the product in its laboratories to verify the foundation of the claim.

Appendix 1 — Default Settings Table

Default values defined in the process of the initial factory setup.

Parameter Description	Default Setting	Parameter Setting Object
Touchstone Data Format	RI - Real-Imaginary	Reflectometer
Allocation of Channels	1	Reflectometer
Active Channel Number	1	Reflectometer
Marker Value Identification Capacity (Stimulus)	8 digits	Reflectometer
Marker Value Identification Capacity (Response)	5 digits	Reflectometer
Vertical Divisions	10	Channel
Channel Title Bar	OFF	Channel
Channel Title	Empty	Channel
Traces per Channel	1	Channel
Active Trace Number	1	Channel
Sweep Type	Linear	Channel
Number of Sweep Points	201	Channel
Stimulus Start Frequency	85 MHz	Channel
Stimulus Stop Frequency	5.4 GHz	Channel
Stimulus CW Frequency	High	Reflectometer
Stimulus IF Bandwidth	10 kHz	Channel
Sweep Measurement Delay	0 sec.	Channel
Sweep Range Setting	Start / Stop	Channel
Number of Segments	1	Channel
Points per Segment	2	Channel
Segment Start Frequency	85 MHz	Channel
Segment Stop Frequency	85 MHz	Channel
Segment Sweep IF Bandwidth	10 kHz	Channel
Segment Sweep Power Level (Table Display)	OFF	Channel
Segment Sweep IF Bandwidth (Table Display)	OFF	Channel
Trigger Mode	Continuous	Reflectometer
Table of Calibration Coefficients	Empty	Reflectometer
Error Correction	ON	Reflectometer
Trace Scale	10 dB/division	Trace
Reference Level Value	0 dB	Trace
Reference Level Position	5 Div.	Trace
Phase Offset	0°	Trace
Electrical Delay	0 sec.	Trace
Trace Display Format	Return Loss (dB)	Trace
Maximum Distance	1.49 m	Trace
Time Domain Kaiser Window	Normal	Channel
Number of Markers	0	Trace